



5.0 or 3.3V, 256 Kbit (32 Kbit x8) ZEROPOWER[®] SRAM

FEATURES SUMMARY

- INTEGRATED, ULTRA LOW POWER SRAM, POWER-FAIL CONTROL CIRCUIT, AND BATTERY
- READ CYCLE TIME EQUALS WRITE CYCLE TIME
- BATTERY LOW FLAG (\overline{BOK})
- AUTOMATIC POWER-FAIL CHIP DESELECT AND WRITE PROTECTION
- WRITE PROTECT VOLTAGES:
(V_{PFD} = Power-fail Deselect Voltage)
 - M48Z35AY: $4.2V \leq V_{PFD} \leq 4.5V$
 - M48Z35AV: $2.7V \leq V_{PFD} \leq 3.0V$
- SELF-CONTAINED BATTERY IN THE CAPHAT[™] DIP PACKAGE
- PACKAGING INCLUDES A 28-LEAD SOIC AND SNAPHAT[®] TOP (to be ordered separately)
- PIN and FUNCTION COMPATIBLE WITH JEDEC STANDARD 32K x 8 SRAMs
- SOIC PACKAGE PROVIDES DIRECT CONNECTION FOR A SNAPHAT TOP WHICH CONTAINS THE BATTERY

Figure 1. 28-pin, CAPHAT[™] DIP Package

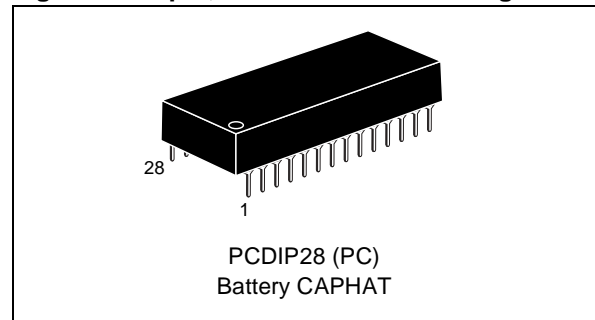

Figure 2. 28-pin SOIC Package

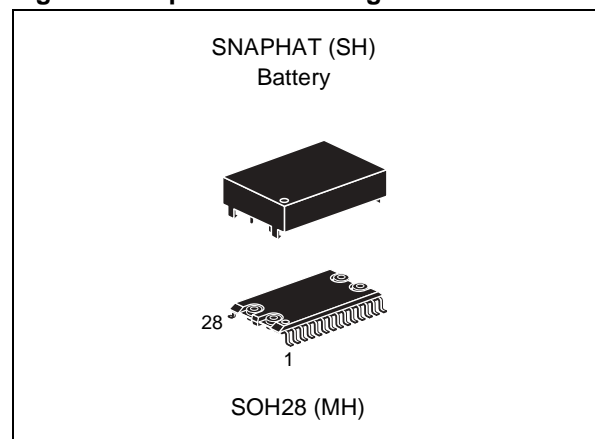

TABLE OF CONTENTS

FEATURES SUMMARY	1
Figure 1. 28-pin, CAPHAT™ DIP Package.....	1
Figure 2. 28-pin SOIC Package	1
SUMMARY DESCRIPTION	4
Figure 3. Logic Diagram	4
Table 1. Signal Names	4
Figure 4. DIP Connections	5
Figure 5. SOIC Connections.....	5
Figure 6. Block Diagram	5
OPERATING MODES	6
Table 2. Operating Modes	6
READ Mode	6
Figure 7. READ Mode AC Waveforms	6
Table 3. READ Mode AC Characteristics	7
WRITE Mode	7
Figure 8. WRITE Enable Controlled, WRITE Mode AC Waveforms.....	7
Figure 9. Chip Enable Controlled, WRITE Mode AC Waveforms.....	8
Table 4. WRITE Mode AC Characteristics	8
Data Retention Mode	9
Figure 10.BOK Check Routine Example	9
V_{CC} Noise And Negative Going Transients	10
Figure 11.Supply Voltage Protection	10
MAXIMUM RATING	11
Table 5. Absolute Maximum Ratings.....	11
DC AND AC PARAMETERS	12
Table 6. Operating and AC Measurement Conditions.....	12
Figure 12.AC Measurement Load Circuit	12
Table 7. Capacitance.....	12
Table 8. DC Characteristics.....	13
Figure 13.Power Down/Up Mode AC Waveforms	14
Table 9. Power Down/Up AC Characteristics	14
Table 10. Power Down/Up Trip Points DC Characteristics	14
PACKAGE MECHANICAL INFORMATION	15
Figure 14.PCDIP28 – 28-pin Plastic DIP, battery CAPHAT™, Package Outline	15
Table 11. PMDIP28 – 28-pin Plastic DIP, battery CAPHAT™, Package Mechanical Data.....	15
Figure 15.SOH28 – 28-lead Plastic Small Outline, battery SNAPHAT, Package Outline	16
Table 12. SOH28 – 28-lead Plastic Small Outline, battery SNAPHAT, Package Mechanical Data	16
Figure 16.SH – 4-pin SNAPHAT Housing for 48mAh Battery, Package Outline.....	17

Table 13. SH – 4-pin SNAPHAT Housing for 48mAh Battery, Package Mechanical Data 17
Figure 17.SH – 4-pin SNAPHAT Housing for 120mAh Battery, Package Outline. 18
Table 14. SH – 4-pin SNAPHAT Housing for 120 mAh Battery, Package Mechanical Data. 18

PART NUMBERING 19

Table 15. Ordering Information Scheme 19
Table 16. SNAPHAT Battery Table 19

REVISION HISTORY. 20

Table 17. Revision History. 20

SUMMARY DESCRIPTION

The M48Z35AY/V ZEROPOWER[®] RAM is a 32 Kbit x 8, non-volatile static RAM that integrates power-fail deselect circuitry and battery control logic on a single die. The monolithic chip is available in two special packages to provide a highly integrated battery backed-up memory solution.

The M48Z35AY/V is a non-volatile pin and function equivalent to any JEDEC standard 32K x8 SRAM. It also easily fits into many ROM, EPROM, and EEPROM sockets, providing the non-volatility of PROMs without any requirement for special WRITE timing or limitations on the number of WRITES that can be performed. The 28 pin 600mil DIP CAPHAT[™] houses the M48Z35AY/V silicon with a long life lithium button cell in a single package.

The 28-pin, 330mil SOIC provides sockets with gold plated contacts at both ends for direct connection to a separate SNAPHAT[®] housing containing the battery. The unique design allows the SNAPHAT battery package to be mounted on top of the SOIC package after the completion of the surface mount process. Insertion of the SNAPHAT housing after reflow prevents potential battery damage due to the high temperatures required for device surface-mounting. The SNAPHAT housing is keyed to prevent reverse insertion.

The SOIC and battery packages are shipped separately in plastic anti-static tubes or in Tape & Reel form.

For the 28-lead SOIC, the battery package (e.g., SNAPHAT) part number is "M4Z28-BR00SH1."

Figure 3. Logic Diagram

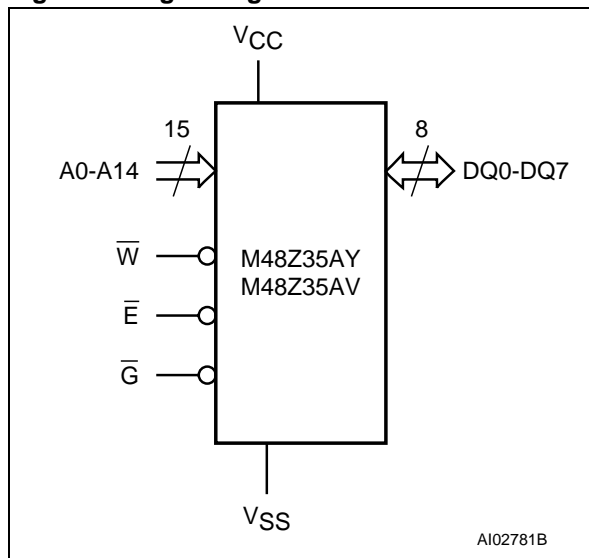

Table 1. Signal Names

A0-A14	Address Inputs
DQ0-DQ7	Data Inputs / Outputs
\bar{E}	Chip Enable Input
\bar{G}	Output Enable Input
\bar{W}	WRITE Enable Input
VCC	Supply Voltage
VSS	Ground

Figure 4. DIP Connections

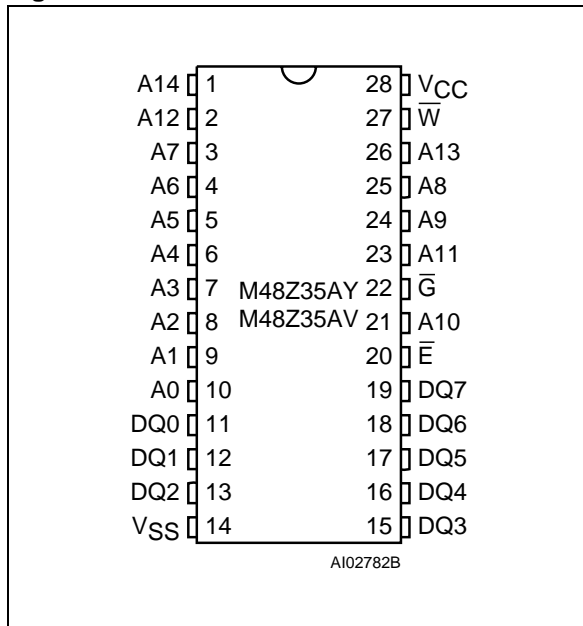

Figure 5. SOIC Connections

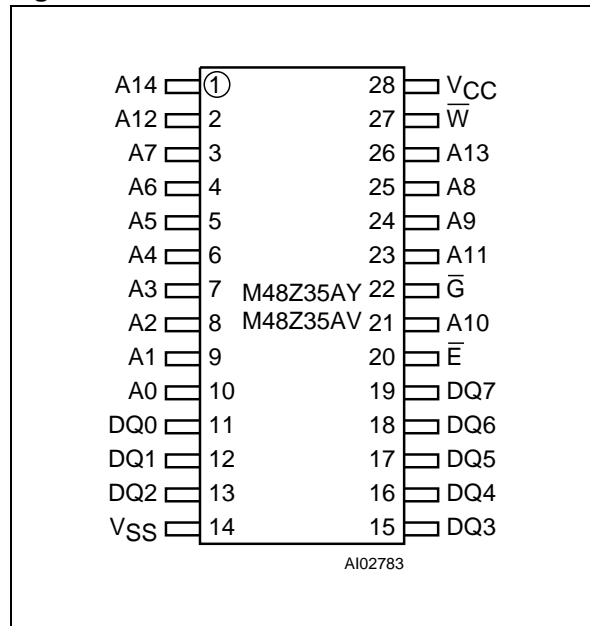
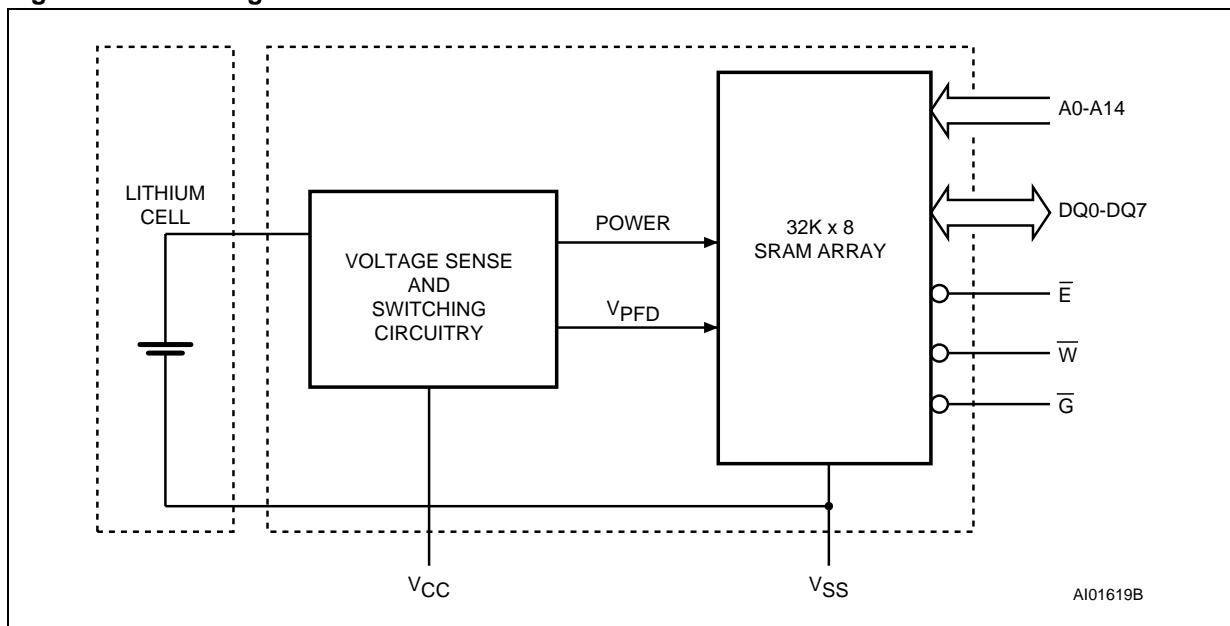

Figure 6. Block Diagram



OPERATING MODES

The M48Z35AY/V also has its own Power-fail Detect circuit. The control circuitry constantly monitors the single power supply for an out of tolerance condition. When V_{CC} is out of tolerance, the circuit write protects the SRAM, providing a high degree

of data security in the midst of unpredictable system operation brought on by low V_{CC} . As V_{CC} falls below approximately V_{SO} , the control circuitry connects the battery which maintains data until valid power returns.

Table 2. Operating Modes

Mode	V_{CC}	\bar{E}	\bar{G}	\bar{W}	DQ0-DQ7	Power
Deselect	4.5 to 5.5V or 3.0 to 3.6V	V_{IH}	X	X	High Z	Standby
WRITE		V_{IL}	X	V_{IL}	D_{IN}	Active
READ		V_{IL}	V_{IL}	V_{IH}	D_{OUT}	Active
READ		V_{IL}	V_{IH}	V_{IH}	High Z	Active
Deselect	V_{SO} to V_{PFD} (min) ⁽¹⁾	X	X	X	High Z	CMOS Standby
Deselect	$\leq V_{SO}$ ⁽¹⁾	X	X	X	High Z	Battery Back-up Mode

Note: X = V_{IH} or V_{IL} ; V_{SO} = Battery Back-up Switchover Voltage.
1. See Table 10., page 14 for details.

READ Mode

The M48Z35AY/V is in the READ Mode whenever \bar{W} (WRITE Enable) is high, \bar{E} (Chip Enable) is low. The device architecture allows ripple-through access of data from eight of 264,144 locations in the static storage array. Thus, the unique address specified by the 15 Address Inputs defines which one of the 32,768 bytes of data is to be accessed. Valid data will be available at the Data I/O pins within Address Access time (t_{AVQV}) after the last address input signal is stable, providing that the \bar{E} and \bar{G} access times are also satisfied. If the \bar{E} and \bar{G} access times are not met, valid data will be

available after the latter of the Chip Enable Access time (t_{ELQV}) or Output Enable Access time (t_{GLQV}).

The state of the eight three-state Data I/O signals is controlled by \bar{E} and \bar{G} . If the outputs are activated before t_{AVQV} , the data lines will be driven to an indeterminate state until t_{AVQV} . If the Address Inputs are changed while \bar{E} and \bar{G} remain active, output data will remain valid for Output Data Hold time (t_{AXQX}) but will go indeterminate until the next Address Access.

Figure 7. READ Mode AC Waveforms

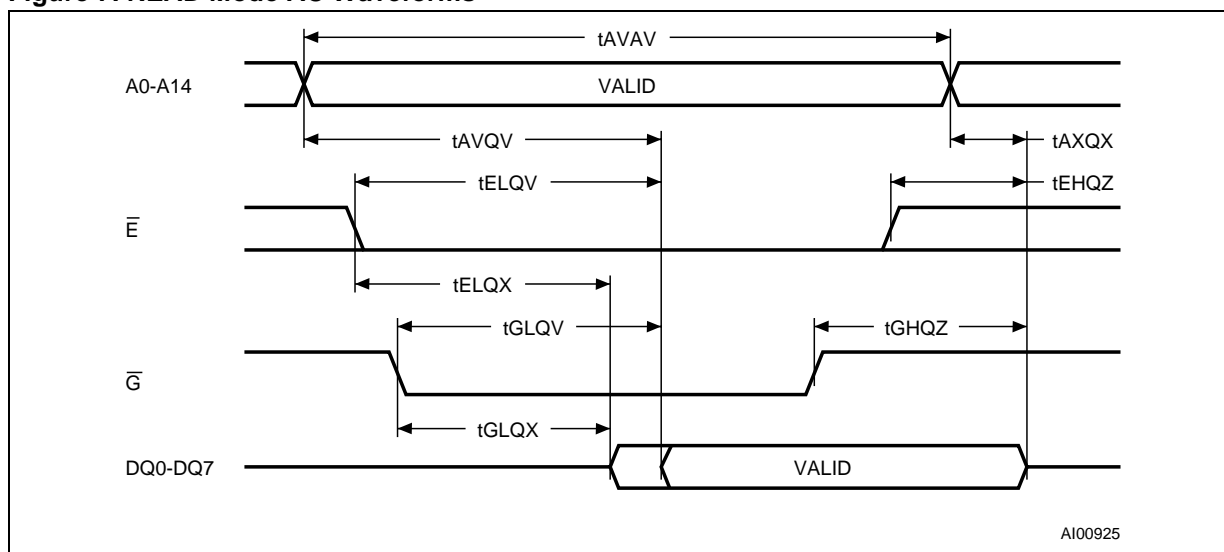

Note: WRITE Enable (\bar{W}) = High.

Table 3. READ Mode AC Characteristics

Symbol	Parameter ⁽¹⁾	M48Z35AY		M48Z35AV		Unit
		-70		-100		
		Min	Max	Min	Max	
t _{AVAV}	READ Cycle Time	70		100		ns
t _{AVQV}	Address Valid to Output Valid		70		100	ns
t _{ELQV}	Chip Enable Low to Output Valid		70		100	ns
t _{GLQV}	Output Enable Low to Output Valid		35		50	ns
t _{ELQX} ⁽²⁾	Chip Enable Low to Output Transition	5		10		ns
t _{GLQX} ⁽²⁾	Output Enable Low to Output Transition	5		5		ns
t _{EHQZ} ⁽²⁾	Chip Enable High to Output Hi-Z		25		50	ns
t _{GHQZ} ⁽²⁾	Output Enable High to Output Hi-Z		25		40	ns
t _{AXQX}	Address Transition to Output Transition	10		10		ns

Note: 1. Valid for Ambient Operating Temperature: T_A = 0 to 70°C or -40 to 85°C; V_{CC} = 4.5 to 5.5V or 3.0 to 3.6V (except where noted).
 2. C_L = 5pF (see Figure 12., page 12).

WRITE Mode

The M48Z35AY/V is in the WRITE Mode whenever W and E are low. The start of a WRITE is referenced from the latter occurring falling edge of W or E. A WRITE is terminated by the earlier rising edge of W or E. The addresses must be held valid throughout the cycle. E or W must return high for a minimum of t_{EHAX} from Chip Enable or t_{WHAX} from WRITE Enable prior to the initiation of another

READ or WRITE cycle. Data-in must be valid t_{DVWH} prior to the end of WRITE and remain valid for t_{WHDX} afterward. G should be kept high during WRITE cycles to avoid bus contention; although, if the output bus has been activated by a low on E and G, a low on W will disable the outputs t_{WLQZ} after W falls.

Figure 8. WRITE Enable Controlled, WRITE Mode AC Waveforms

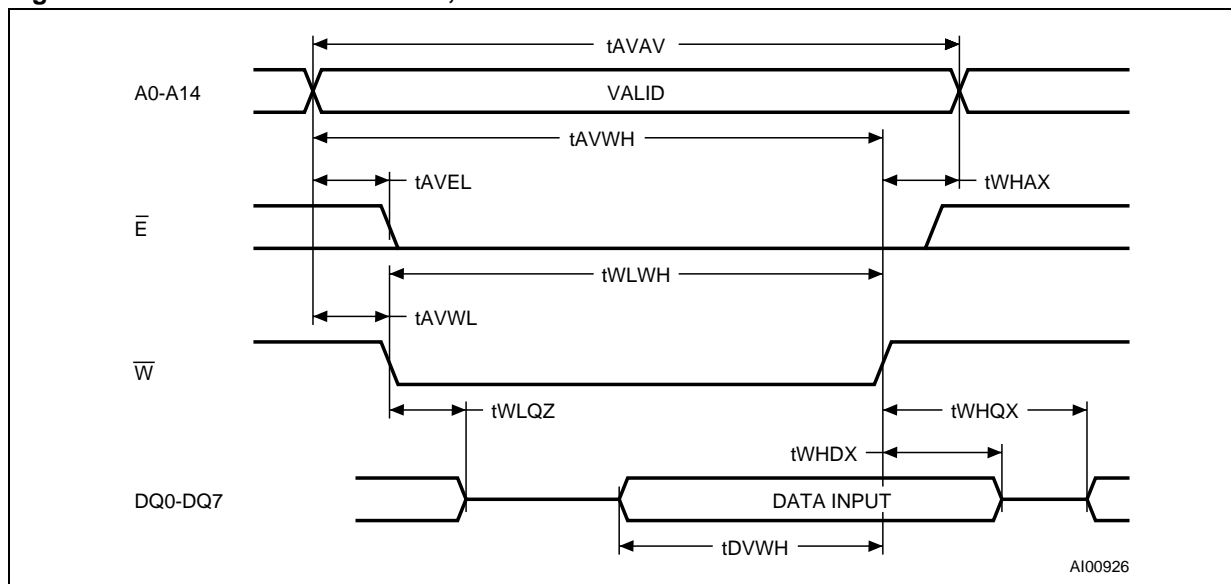

Figure 9. Chip Enable Controlled, WRITE Mode AC Waveforms

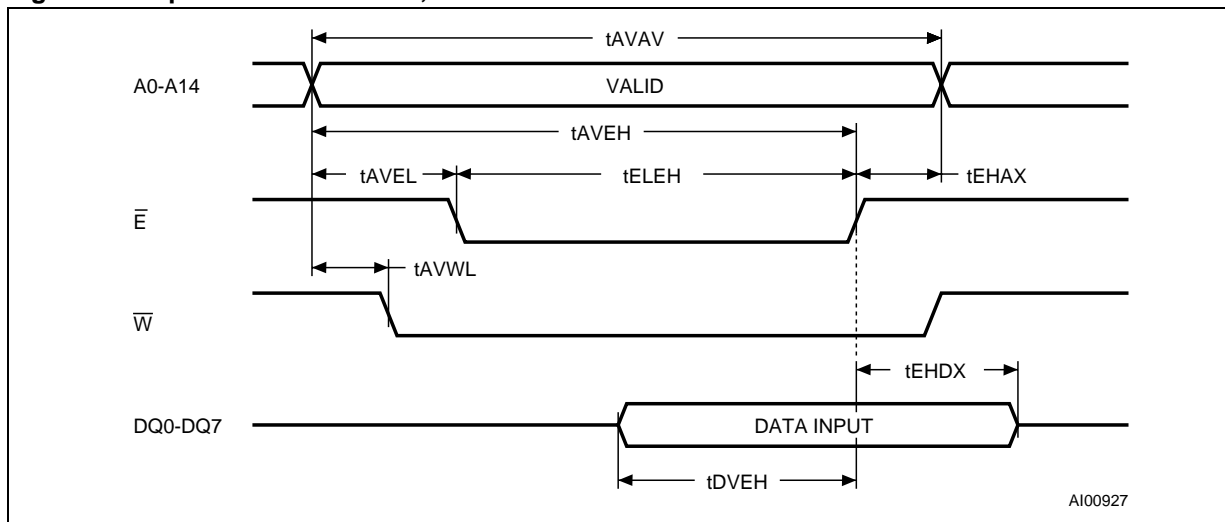

Table 4. WRITE Mode AC Characteristics

Symbol	Parameter ⁽¹⁾	M48Z35AY		M48Z35AV		Unit
		-70		-100		
		Min	Max	Min	Max	
t_{AVAV}	WRITE Cycle Time	70		100		ns
t_{AVWL}	Address Valid to WRITE Enable Low	0		0		ns
t_{AVEL}	Address Valid to Chip Enable Low	0		0		ns
t_{WLWH}	WRITE Enable Pulse Width	50		80		ns
t_{ELEH}	Chip Enable Low to Chip Enable High	55		80		ns
t_{WHAX}	WRITE Enable High to Address Transition	0		10		ns
t_{EHAX}	Chip Enable High to Address Transition	0		10		ns
t_{DVWH}	Input Valid to WRITE Enable High	30		50		ns
t_{DVEH}	Input Valid to Chip Enable High	30		50		ns
t_{WHDX}	WRITE Enable High to Input Transition	5		5		ns
t_{EHDX}	Chip Enable High to Input Transition	5		5		ns
$t_{WLQZ}^{(2,3)}$	WRITE Enable Low to Output Hi-Z		25		50	ns
t_{AVWH}	Address Valid to WRITE Enable High	60		80		ns
t_{AVEH}	Address Valid to Chip Enable High	60		80		ns
$t_{WHQX}^{(2,3)}$	WRITE Enable High to Output Transition	5		10		ns

Note: 1. Valid for Ambient Operating Temperature: $T_A = 0$ to 70°C or -40 to 85°C ; $V_{CC} = 4.5$ to 5.5V or 3.0 to 3.6V (except where noted).
 2. $C_L = 5\text{pF}$ (see Figure 12., page 12).
 3. If \bar{E} goes low simultaneously with \bar{W} going low, the outputs remain in the high impedance state.

Data Retention Mode

With valid V_{CC} applied, the M48Z35AY/V operates as a conventional BYTEWIDE™ static RAM. Should the supply voltage decay, the RAM will automatically power-fail deselect, write protecting itself when V_{CC} falls within the V_{PFD} (max), V_{PFD} (min) window. All outputs become high impedance, and all inputs are treated as “Don't care.”

Note: A power failure during a WRITE cycle may corrupt data at the currently addressed location, but does not jeopardize the rest of the RAM's content. At voltages below $V_{PFD}(\text{min})$, the user can be assured the memory will be in a write protected state, provided the V_{CC} fall time is not less than t_F . The M48Z35AY/V may respond to transient noise spikes on V_{CC} that reach into the deselect window during the time the device is sampling V_{CC} . Therefore, decoupling of the power supply lines is recommended.

When V_{CC} drops below V_{SO} , the control circuit switches power to the internal battery which preserves data. The internal button cell will maintain data in the M48Z35AY/V for an accumulated period of at least 10 years (at 25°C) when V_{CC} is less than V_{SO} .

As system power returns and V_{CC} rises above V_{SO} , the battery is disconnected, and the power supply is switched to external V_{CC} . Write protection continues until V_{CC} reaches $V_{PFD}(\text{min})$ plus $t_{REC}(\text{min})$. Normal RAM operation can resume t_{REC} after V_{CC} exceeds $V_{PFD}(\text{max})$.

Also, as V_{CC} rises, the battery voltage is checked. If the voltage is less than approximately 2.5V, an internal Battery Not OK (BOK) flag will be set. The BOK flag can be checked after power up. If the BOK flag is set, the first WRITE attempted will be blocked. The flag is automatically cleared after the first WRITE, and normal RAM operation resumes. Figure 10 illustrates how a BOK check routine could be structured.

For more information on Battery Storage Life refer to the Application Note AN1012.

Figure 10. BOK Check Routine Example

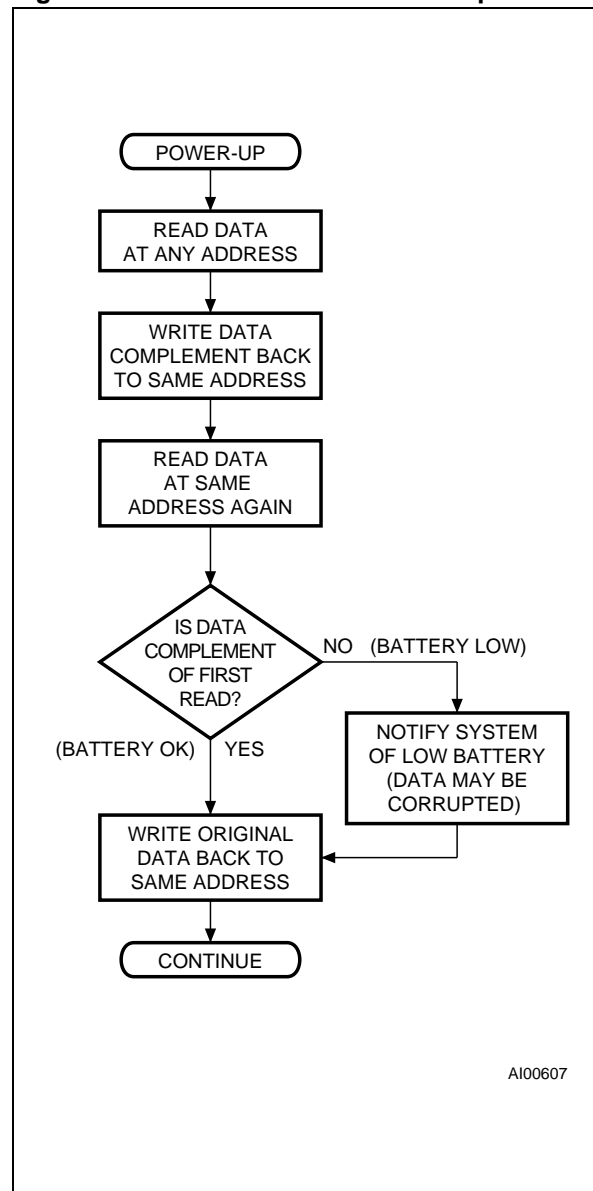

AI00607

V_{CC} Noise And Negative Going Transients

I_{CC} transients, including those produced by output switching, can produce voltage fluctuations, resulting in spikes on the V_{CC} bus. These transients can be reduced if capacitors are used to store energy which stabilizes the V_{CC} bus. The energy stored in the bypass capacitors will be released as low going spikes are generated or energy will be absorbed when overshoots occur. A ceramic bypass capacitor value of 0.1μF (see Figure 11) is recommended in order to provide the needed filtering.

In addition to transients that are caused by normal SRAM operation, power cycling can generate negative voltage spikes on V_{CC} that drive it to values below V_{SS} by as much as one volt. These negative spikes can cause data corruption in the SRAM while in battery backup mode. To protect from these voltage spikes, ST recommends connecting a schottky diode from V_{CC} to V_{SS} (cathode connected to V_{CC}, anode to V_{SS}). (Schottky diode 1N5817 is recommended for through hole and MBRS120T3 is recommended for surface mount).

Figure 11. Supply Voltage Protection

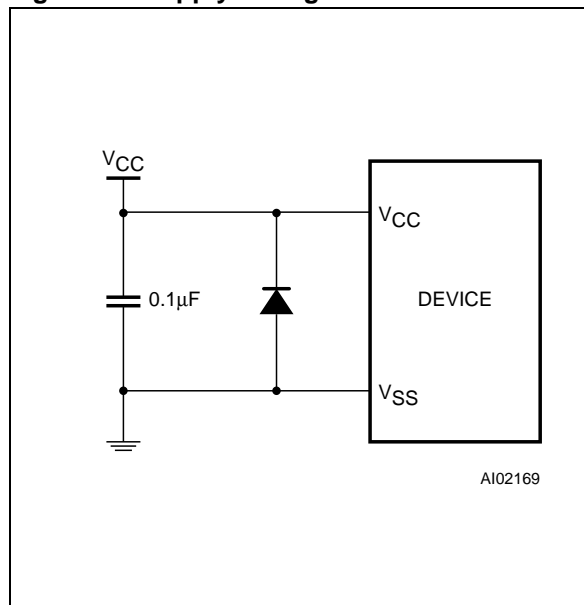

MAXIMUM RATING

Stressing the device above the rating listed in the “Absolute Maximum Ratings” table may cause permanent damage to the device. These are stress ratings only and operation of the device at these or any other conditions above those indicated in the Operating sections of this specification is

not implied. Exposure to Absolute Maximum Rating conditions for extended periods may affect device reliability. Refer also to the STMicroelectronics SURE Program and other relevant quality documents.

Table 5. Absolute Maximum Ratings

Symbol	Parameter		Value	Unit
T _A	Ambient Operating Temperature	Grade 1	0 to 70	°C
		Grade 6	–40 to 85	°C
T _{STG}	Storage Temperature (V _{CC} Off, Oscillator Off)	SNAPHAT®	–40 to 85	°C
		SOIC	–55 to 125	°C
T _{SLD} ^(1,2,3)	Lead Solder Temperature for 10 seconds		260	°C
V _{IO}	Input or Output Voltages	M48Z35AY	–0.3 to 7.0	V
		M48Z35AV	–0.3 to 4.6	V
V _{CC}	Supply Voltage	M48Z35AY	–0.3 to 7.0	V
		M48Z35AV	–0.3 to 4.6	V
I _O	Output Current		20	mA
P _D	Power Dissipation		1	W

- Note: 1. For DIP package: Soldering temperature not to exceed 260°C for 10 seconds (total thermal budget not to exceed 150°C for longer than 30 seconds).
 2. For SO package, standard (SnPb) lead finish: Reflow at peak temperature of 225°C (total thermal budget not to exceed 180°C for between 90 to 150 seconds).
 3. For SO package, Lead-free (Pb-free) lead finish: Reflow at peak temperature of 260°C (total thermal budget not to exceed 245°C for greater than 30 seconds).

CAUTION: Negative undershoots below –0.3V are not allowed on any pin while in the Battery Back-up mode.

CAUTION: Do NOT wave solder SOIC to avoid damaging SNAPHAT sockets.

DC AND AC PARAMETERS

This section summarizes the operating and measurement conditions, as well as the DC and AC characteristics of the device. The parameters in the following DC and AC Characteristic tables are derived from tests performed under the Measure-

ment Conditions listed in the relevant tables. Designers should check that the operating conditions in their projects match the measurement conditions when using the quoted parameters.

Table 6. Operating and AC Measurement Conditions

Parameter		M48Z35AY	M48Z35AV	Unit
Supply Voltage (V _{CC})		4.5 to 5.5V	3.0 to 3.6	V
Ambient Operating Temperature (T _A)	Grade 1	0 to 70	0 to 70	°C
	Grade 6	-40 to 85	-40 to 85	°C
Load Capacitance (C _L)		100	50	pF
Input Rise and Fall Times		≤ 5	≤ 5	ns
Input Pulse Voltages		0 to 3	0 to 3	V
Input and Output Timing Ref. Voltages		1.5	1.5	V

Note: Output Hi-Z is defined as the point where data is no longer driven.

Figure 12. AC Measurement Load Circuit

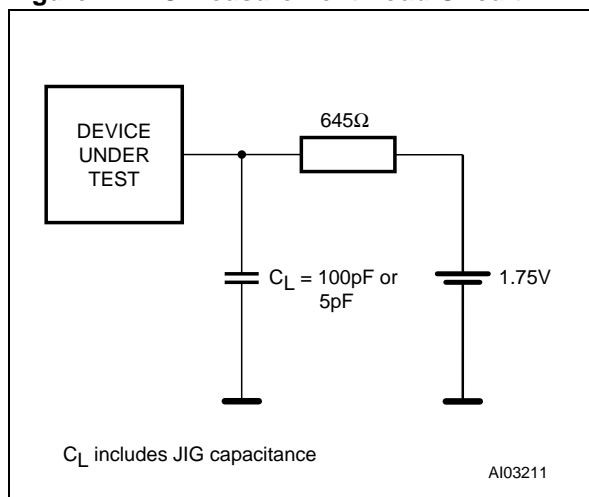

Note: 50pF for M48Z35AV.

Table 7. Capacitance

Symbol	Parameter ^(1,2)	Min	Max	Unit
C _{IN}	Input Capacitance		10	pF
C _{IO} ⁽³⁾	Input / Output Capacitance		10	pF

Note: 1. Effective capacitance measured with power supply at 5V. Sampled only, not 100% tested.
 2. At 25°C, f = 1MHz.
 3. Outputs deselected.

Table 8. DC Characteristics

Symbol	Parameter	Test Condition ⁽¹⁾	Min	Max	Unit
$I_{LI}^{(2)}$	Input Leakage Current	$0V \leq V_{IN} \leq V_{CC}$		± 1	μA
$I_{LO}^{(2)}$	Output Leakage Current	$0V \leq V_{OUT} \leq V_{CC}$		± 5	μA
I_{CC}	Supply Current	Outputs open		50	mA
I_{CC1}	Supply Current (TTL Standby)	$\bar{E} = V_{IH}$		3	mA
I_{CC2}	Supply Current (CMOS Standby)	$\bar{E} = V_{CC} - 0.2V$		3	mA
$V_{IL}^{(3)}$	Input Low Voltage		-0.3	0.8	V
V_{IH}	Input High Voltage		2.2	$V_{CC} + 0.3$	V
V_{OL}	Output Low Voltage	$I_{OL} = 2.1mA$		0.4	V
V_{OH}	Output High Voltage	$I_{OH} = -1mA$	2.4		V

Note: 1. Valid for Ambient Operating Temperature: $T_A = 0$ to $70^\circ C$ or -40 to $85^\circ C$; $V_{CC} = 4.5$ to $5.5V$ or 3.0 to $3.6V$ (except where noted).
 2. Outputs deselected.
 3. Negative spikes of $-1V$ allowed for up to $10ns$ once per cycle.

Figure 13. Power Down/Up Mode AC Waveforms

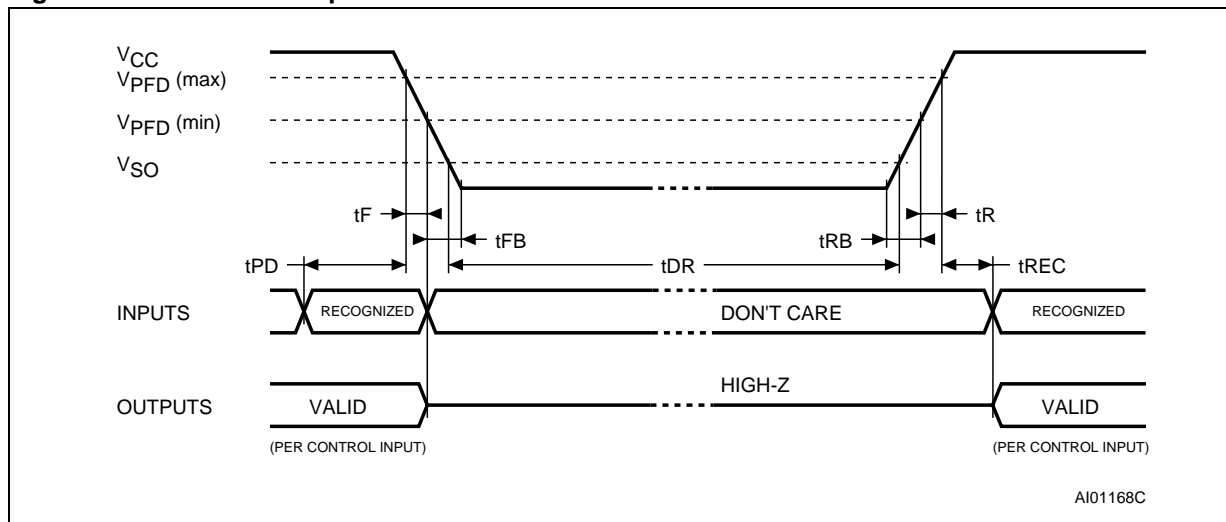

Table 9. Power Down/Up AC Characteristics

Symbol	Parameter ⁽¹⁾	Min	Max	Unit
t _{PD}	\bar{E} or \bar{W} at V _{IH} before Power Down	0		μs
t _F ⁽²⁾	V _{PFD} (max) to V _{PFD} (min) V _{CC} Fall Time	300		μs
t _{FB} ⁽³⁾	V _{PFD} (min) to V _{SS} V _{CC} Fall Time	10		μs
t _R	V _{PFD} (min) to V _{PFD} (max) V _{CC} Rise Time	10		μs
t _{RB}	V _{SS} to V _{PFD} (min) V _{CC} Rise Time	1		μs
t _{REC} ⁽⁴⁾	V _{PFD} (max) to Inputs Recognized	40	200	ms

Note: 1. Valid for Ambient Operating Temperature: T_A = 0 to 70°C or -40 to 85°C; V_{CC} = 4.5 to 5.5V or 3.0 to 3.6V (except where noted).
 2. V_{PFD} (max) to V_{PFD} (min) fall time of less than t_F may result in deselection/write protection not occurring until 200μs after V_{CC} passes V_{PFD} (min).
 3. V_{PFD} (min) to V_{SS} fall time of less than t_{FB} may cause corruption of RAM data.
 4. t_{REC} (min) = 20ms for industrial temperature Grade (6) device.

Table 10. Power Down/Up Trip Points DC Characteristics

Symbol	Parameter ^(1,2)		Min	Typ	Max	Unit
V _{PFD}	Power-fail Deselect Voltage	M48Z35AY	4.2	4.35	4.5	V
		M48Z35AV	2.7	2.9	3.0	V
V _{SO}	Battery Back-up Switchover Voltage	M48Z35AY		3.0		V
		M48Z35AV		V _{PFD} - 100mV		V
t _{DR} ⁽³⁾	Expected Data Retention Time		10			YEARS

Note: 1. All voltages referenced to V_{SS}.
 2. Valid for Ambient Operating Temperature: T_A = 0 to 70°C or -40 to 85°C; V_{CC} = 4.5 to 5.5V or 3.0 to 3.6V (except where noted).
 3. At 25°C, V_{CC} = 0V.

PACKAGE MECHANICAL INFORMATION

Figure 14. PCDIP28 – 28-pin Plastic DIP, battery CAPHAT™, Package Outline

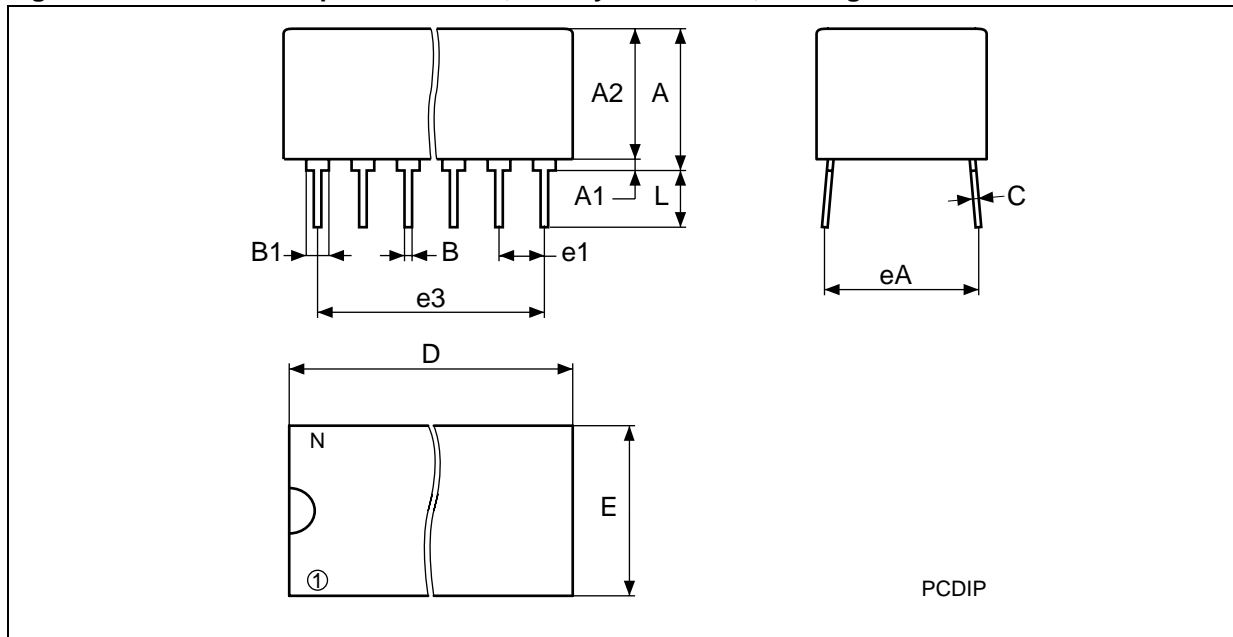

Note: Drawing is not to scale.

Table 11. PMDIP28 – 28-pin Plastic DIP, battery CAPHAT™, Package Mechanical Data

Symb	mm			inches		
	Typ	Min	Max	Typ	Min	Max
A		8.89	9.65		0.350	0.380
A1		0.38	0.76		0.015	0.030
A2		8.38	8.89		0.330	0.350
B		0.38	0.53		0.015	0.021
B1		1.14	1.78		0.045	0.070
C		0.20	0.31		0.008	0.012
D		39.37	39.88		1.550	1.570
E		17.83	18.34		0.702	0.722
e1		2.29	2.79		0.090	0.110
e3		29.72	36.32		1.170	1.430
eA		15.24	16.00		0.600	0.630
L		3.05	3.81		0.120	0.150
N		28			28	

M48Z35AY, M48Z35AV

Figure 15. SOH28 – 28-lead Plastic Small Outline, battery SNAPHAT, Package Outline

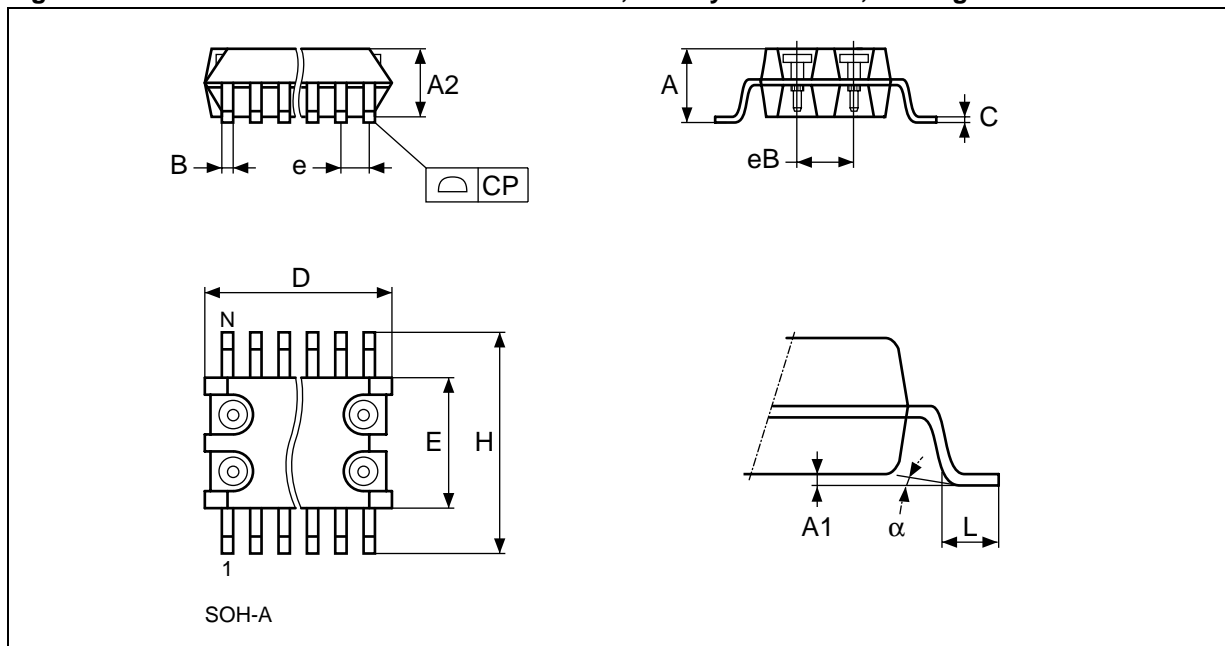

Note: Drawing is not to scale.

Table 12. SOH28 – 28-lead Plastic Small Outline, battery SNAPHAT, Package Mechanical Data

Symbol	mm			inch		
	Typ	Min	Max	Typ	Min	Max
A			3.05			0.120
A1		0.05	0.36		0.002	0.014
A2		2.34	2.69		0.092	0.106
B		0.36	0.51		0.014	0.020
C		0.15	0.32		0.006	0.012
D		17.71	18.49		0.697	0.728
E		8.23	8.89		0.324	0.350
e	1.27	–	–	0.050	–	–
eB		3.20	3.61		0.126	0.142
H		11.51	12.70		0.453	0.500
L		0.41	1.27		0.016	0.050
alpha		0°	8°		0°	8°
N	28			28		
CP			0.10			0.004

Figure 16. SH – 4-pin SNAPHAT Housing for 48mAh Battery, Package Outline

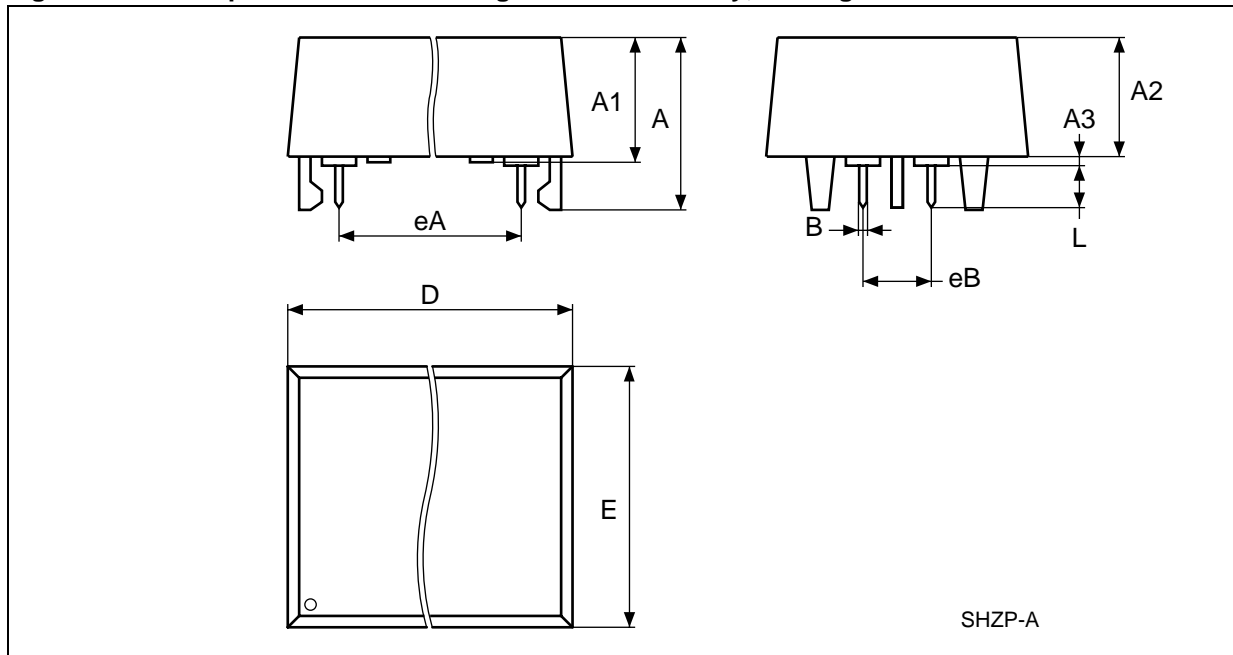

Note: Drawing is not to scale.

Table 13. SH – 4-pin SNAPHAT Housing for 48mAh Battery, Package Mechanical Data

Symb	mm			inches		
	Typ	Min	Max	Typ	Min	Max
A			9.78			0.385
A1		6.73	7.24		0.265	0.285
A2		6.48	6.99		0.255	0.275
A3			0.38			0.015
B		0.46	0.56		0.018	0.022
D		21.21	21.84		0.835	0.860
E		14.22	14.99		0.560	0.590
eA		15.55	15.95		0.612	0.628
eB		3.20	3.61		0.126	0.142
L		2.03	2.29		0.080	0.090

Figure 17. SH – 4-pin SNAPHAT Housing for 120mAh Battery, Package Outline

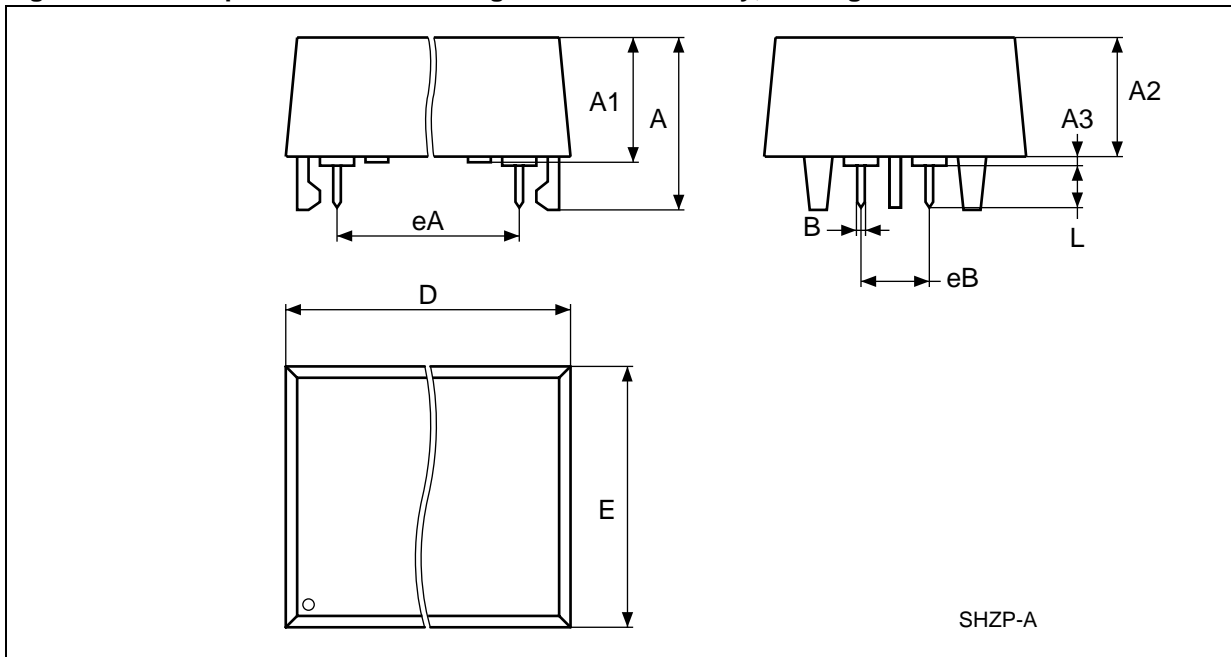

Note: Drawing is not to scale.

Table 14. SH – 4-pin SNAPHAT Housing for 120 mAh Battery, Package Mechanical Data

Symb	mm			inches		
	Typ	Min	Max	Typ	Min	Max
A			10.54			0.415
A1		8.00	8.51		0.315	0.335
A2		7.24	8.00		0.285	0.315
A3			0.38			0.015
B		0.46	0.56		0.018	0.022
D		21.21	21.84		0.835	0.860
E		17.27	18.03		0.680	0.710
eA		15.55	15.95		0.612	0.628
eB		3.20	3.61		0.126	0.142
L		2.03	2.29		0.080	0.090

PART NUMBERING

Table 15. Ordering Information Scheme

Example:	M48Z	35AY	-70	MH	1	E
Device Type						
M48Z						
Supply Voltage and Write Protect Voltage						
35AY = $V_{CC} = 4.5$ to $5.5V$; $V_{PFD} = 4.2$ to $4.5V$						
35AV = $V_{CC} = 3.0$ to $3.6V$; $V_{PFD} = 2.7$ to $3.0V$						
Speed						
-70 = 70ns (35AY)						
-10 = 100ns (35AV)						
Package						
PC = PCDIP28						
MH ⁽¹⁾ = SOH28						
Temperature Range						
1 = 0 to 70°C						
6 ⁽²⁾ = -40 to 85°C						
Shipping Method						

For SOH28:

blank = Tubes (Not for New Design - Use E)

E = Lead-free Package (ECO[®]PACK[®]), Tubes

F = Lead-free Package (ECO[®]PACK[®]), Tape & Reel

TR = Tape & Reel (Not for New Design - Use F)

For PCDIP28:

blank = Tubes

Note: 1. The SOIC package (SOH28) requires the SNAPHAT[®] battery package which is ordered separately under the part number "M4Zxx-BR00SH" in plastic tube or "M4Zxx-BR00SHTR" in Tape & Reel form (see Table 16).
 2. Industrial temperature grade available in SOIC package (SOH28) only.

Caution: Do not place the SNAPHAT battery package "M4Zxx-BR00SH" in conductive foam as it will drain the lithium button-cell battery.

For other options, or for more information on any aspect of this device, please contact the ST Sales Office nearest you.

Table 16. SNAPHAT Battery Table

Part Number	Description	Package
M4Z28-BR00SH	Lithium Battery (48mAh) SNAPHAT	SH
M4Z32-BR00SH	Lithium Battery (120mAh) SNAPHAT	SH

REVISION HISTORY**Table 17. Revision History**

Date	Version	Revision Details
September 1999	1.0	First Issue
20-Apr-00	1.1	SH and SH28 packages for 2-pin and 2-socket removed
22-Jun-01	2.0	Reformatted; added temperature information (Table 7, 8, 3, 4, 9, 10)
05-Jul-01	2.1	Removed reference to "Crystal" in Features Summary
17-Dec-01	2.2	Changed speed grade designator to "-10" (Table 15)
29-May-02	2.3	Modified reflow time and temperature footnotes (Table 5)
03-Oct-02	2.4	Update V_{CC} for Supply Voltage (Table 5)
07-Nov-02	2.5	Update Absolute Maximum Ratings (Table 5)
02-Apr-03	3.0	v2.2 template applied; test condition updated (Table 10)
24-Mar-04	4.0	Reformatted; updated Lead-free information (Table 5, 15)

Information furnished is believed to be accurate and reliable. However, STMicroelectronics assumes no responsibility for the consequences of use of such information nor for any infringement of patents or other rights of third parties which may result from its use. No license is granted by implication or otherwise under any patent or patent rights of STMicroelectronics. Specifications mentioned in this publication are subject to change without notice. This publication supersedes and replaces all information previously supplied. STMicroelectronics products are not authorized for use as critical components in life support devices or systems without express written approval of STMicroelectronics.

The ST logo is a registered trademark of STMicroelectronics.

All other names are the property of their respective owners.

© 2004 STMicroelectronics - All rights reserved

STMicroelectronics GROUP OF COMPANIES
Australia - Belgium - Brazil - Canada - China - Czech Republic - Finland - France - Germany -
Hong Kong - India - Israel - Italy - Japan - Malaysia - Malta - Morocco - Singapore -
Spain - Sweden - Switzerland - United Kingdom - United States
www.st.com

This datasheet has been download from:

www.datasheetcatalog.com

Datasheets for electronics components.