



### FEATURES:

- Wide 4:1 input range
- Remote On/Off control
- High efficiency up to 87%
- Over Voltage/Overload Protection
- Operating temperature -40°C to + 85°C
- Input / Output Isolation 1600 & 3000VDC
- Continuous short circuit protection
- Under voltage lockout for 3000VDC models



### Models Single output

Model	Input Voltage (V)	Output Voltage (V)	Output Current max (mA)	Isolation (VDC)	Max Capacitive Load(uF)	Efficiency (%)
AM8TW-2403SZ	9-36	3.3	2000	1600	1330	83
AM8TW-2405SZ	9-36	5	1500	1600	1330	86
AM8TW-2412SZ	9-36	12	665	1600	288	87
AM8TW-2415SZ	9-36	15	535	1600	200	87
AM8TW-4803SZ	18-75	3.3	2000	1600	1330	82
AM8TW-4805SZ	18-75	5	1500	1600	1330	86
AM8TW-4812SZ	18-75	12	665	1600	288	87
AM8TW-4815SZ	18-75	15	535	1600	200	87
<b>Separator</b>						
AM8TW-2403SH30Z	13-70	3.3	2000	3000	1330	83
AM8TW-2405SH30Z	13-70	5	1500	3000	1330	86
AM8TW-2412SH30Z	13-70	12	665	3000	330	85
AM8TW-2415SH30Z	13-70	15	535	3000	220	86
AM8TW-11003SH30Z	42-176	3.3	2000	3000	1330	81
AM8TW-11005SH30Z	42-176	5	1500	3000	1330	84
AM8TW-11012SH30Z	42-176	12	665	3000	330	84
AM8TW-11015SH30Z	42-176	15	535	3000	220	83

### Models Dual output

Model	Input Voltage (V)	Output Voltage (V)	Output Current max (mA)	Isolation (VDC)	Max Capacitive Load(uF)	Efficiency (%)
AM8TW-2405DZ	9-36	±5	±800	1600	±900	84
AM8TW-2412DZ	9-36	±12	±335	1600	±133	86
AM8TW-2415DZ	9-36	±15	±265	1600	±90	87
AM8TW-4805DZ	18-75	±5	±800	1600	±900	84
AM8TW-4812DZ	18-75	±12	±335	1600	±133	87
AM8TW-4815DZ	18-75	±15	±265	1600	±90	87
<b>Separator</b>						
AM8TW-2405DH30Z	13-70	±5	±800	3000	±900	83
AM8TW-2412DH30Z	13-70	±12	±335	3000	±220	85
AM8TW-2415DH30Z	13-70	±15	±265	3000	±100	86
AM8TW-11005DH30Z	42-176	±5	±800	3000	±900	80
AM8TW-11012DH30Z	42-176	±12	±335	3000	±220	82
AM8TW-11015DH30Z	42-176	±15	±265	3000	±100	83

NOTE: All specifications in this datasheet are measured at an ambient temperature of 25°C, humidity<75%, nominal input voltage and at rated output load unless otherwise specified.

## Input Specifications

Parameters	Nominal	Typical	Maximum	Units
Voltage range	24 for 1600VDC models	9-36		VDC
	48 for 1600VDC models	18-75		
	24V or 48V for 3000VDC models	13-70		
	110V	42-176		
Filter	$\pi$ (Pi) Network			
Startup time	For 1600VDC Isolation models	20		ms
	For 3000VDC Isolation models	30		
Absolute Maximum Rating	24 for 1600VDC models		-0.7-50	VDC
	48 for 1600VDC models		-0.7-100	
	24V or 48V for 3000VDC models		100	
	110V		185	
Peak Input Voltage time			100	ms
On/Off control	ON – 3.0 ~ 12VDC (or open)			
	OFF -0~-1.2VDC (or short between pin 1 and 2/3), Idle current 5mA, typ.			
No Load Input Current		15		mA
Input reflected current	With 12uH inductance	20		mAp-p
Under voltage Lockout (On/Off)	24V or 48V for 3000VDC models	On – 12V/ Off – 11.7		VDC
	110V	On – 39.5V/ Off – 38		
Transient recovery time	25% load step change, 1A/us	250		uS
Transient recovery deviation			$\pm 3$	%
	3.3V output models only		$\pm 5$	

## Isolation Specifications

Parameters	Conditions	Typical	Rated	Units
Tested I/O voltage	60 sec		1600 & 3000	VDC
Tested metal case to Input and Output	60 sec		1000	VDC
Resistance		>1000		MOhm
Capacitance	For 1600VDC Isolation models	1500		pF
	For 3000VDC Isolation models	1000		

## Output Specifications

Parameters	Conditions	Typical	Maximum	Units
Voltage accuracy		$\pm 1$		%
	48V nom 3000VDC models only	$\pm 1.5$		
Over voltage protection	Zener Diode Clamp			%
Over load protection	For 1600VDC Isolation models	150		%
	For 3000VDC Isolation models	160		
	For 3000VDC Isolation models 48V nom	170		
Short Circuit protection	Continuous			
Short circuit restart	Auto-Recovery			
Line voltage regulation	HL-LL 1600VDC models	$\pm 0.2$		% of Vin
	HL-LL 3000VDC models	$\pm 0.5$		
Load voltage regulation	0 – 100% load	$\pm 0.5$		%
Cross regulation (Dual)	25% load on one output - 100% load on second load	$\pm 5$		%
Temperature coefficient		$\pm 0.02$		%/°C
Ripple & Noise*	20MHz Bandwidth	75		mV p-p
Minimum Load Current		0		% of Max

\*Measured with 1uF ceramic capacitor.

## General Specifications

Parameters	Conditions	Typical	Maximum	Units
Switching frequency	100% load 1600VDC models	270		KHz
	24 & 48V nom 3000VDC models	330		
	110V	220		
Operating temperature	Derating above +70	-40 to +85		°C
Storage temperature	-55 to +125			°C
Maximum case temperature			105	°C
Cooling	Free air convection			
Humidity			95	% RH
Case material	Nickel plated Cooper			
Weight	18			g
Dimensions (L x W x H)	1.25 x 0.80 x 0.40 inches	31.80 x 20.30 x 10.20 mm		
MTBF	> 1,000,100 hours(MIL-HDBK-217F , Ground Benign, t=+25°C)			
Maximum soldering temperature	1.5mm from case for 10sec		260	°C

## Environment Approval (for 3000V models)

Parameters	Conditions
Cooling & heating	EN50155, Class TX
Shock	According to EN61373, category 1, class B
	Wave form: Half sine wave
	Acceleration amplitude: Axis X – 5G, Axis Y and Z – 3G
	Bump duration: 30 ms
	Number of bumps: 18 (3 in each direction for every axis)
	Converter operation before and after test, body mounted (on chassis)
Vibrations	According to EN61373, category 1, class B
	5-150Hz
	10min per axis & 5h per axis

## Safety Specifications

Parameters	
Agency Approval	CE
Standards	IEC/EN60950-1
Standards for 1600VDC models	EN55022 Class A, EN55024
	IEC61000-4-2, Perf. Criteria B
	IEC61000-4-3, Perf. Criteria A
	IEC61000-4-4, Perf. Criteria B (external 330uF/100V cap required)
	IEC61000-4-5, Perf. Criteria B (external 330uF/100V cap required)
	IEC61000-4-6, Perf. Criteria A
	IEC61000-4-8, Perf. Criteria A
Standards for 3000VDC models	EN50155, with external circuit
	IEC61000-4-2, ±8KV/±6KV, Perf. Criteria A
	IEC61000-4-3, Perf. Criteria A
	IEC61000-4-4, ±2KV, Perf. Criteria A, with external circuit
	IEC61000-4-5, ±2KV, Perf. Criteria A, with external circuit
	IEC61000-4-6, Perf. Criteria A
	IEC61000-4-8, 10A/m, Perf. Criteria A

**Pin Out Specifications**

Pin	Single	Dual
1	Remote On/Off	Remote On/Off
2	-V Input	-V Input
3	-V Input	-V Input
9	No Pin	Common
11	N.C.	-V Output
14	+V Output	+V Output
16	-V Output	Common
22	+V Input	+V Input
23	+V Input	+V Input

N.C.: Not Connected

**Dimensions**

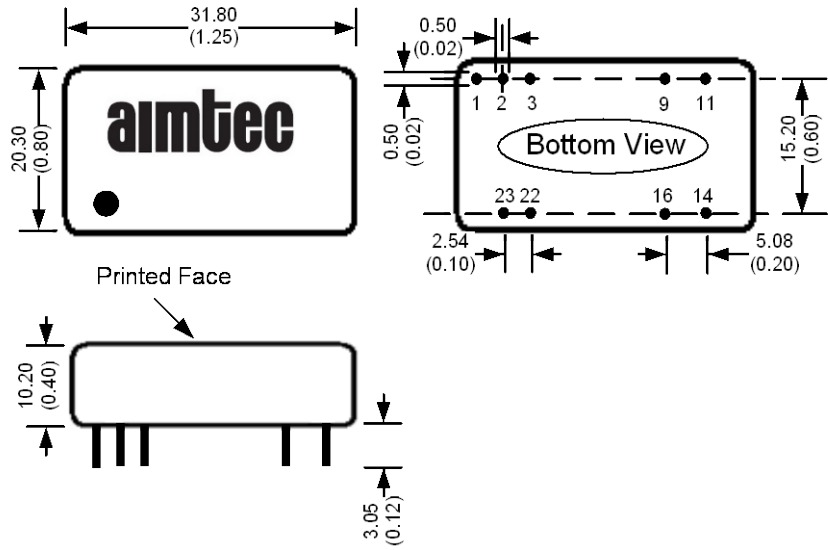

**Derating**

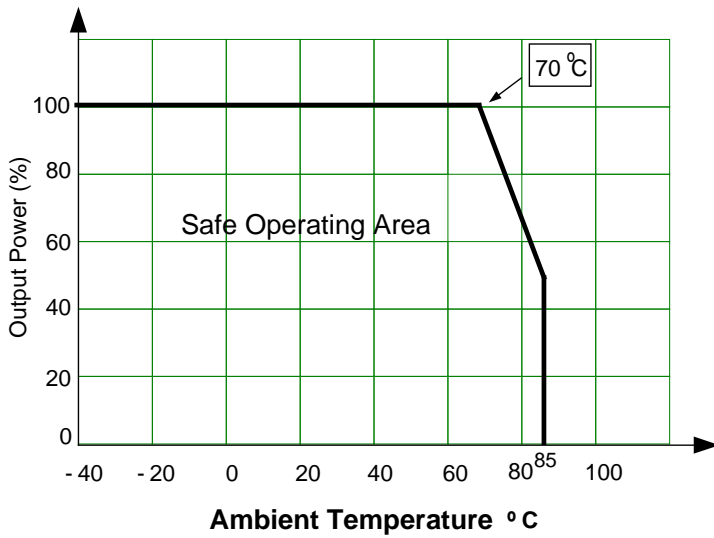

**Recommended Circuits for 1600VDC isolated models**

**Conducted Emissions**

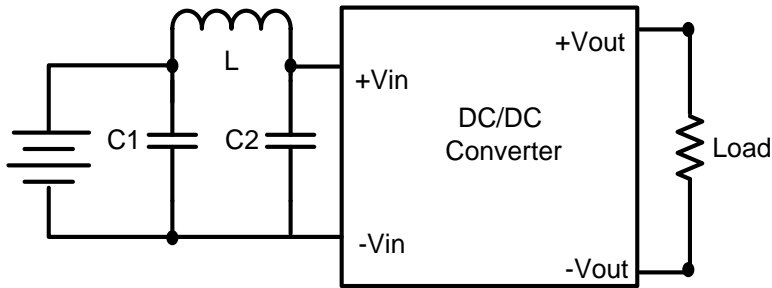

C1	L	C2
2.2uF, 100V	12uH	2.2uF, 100V

**Surge/EFT**

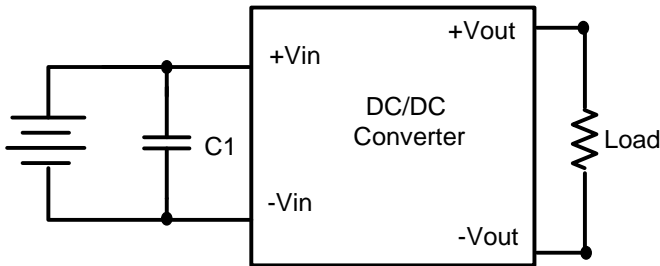

C1
330uF, 100V

**Recommended Circuits for 3000VDC isolated models**

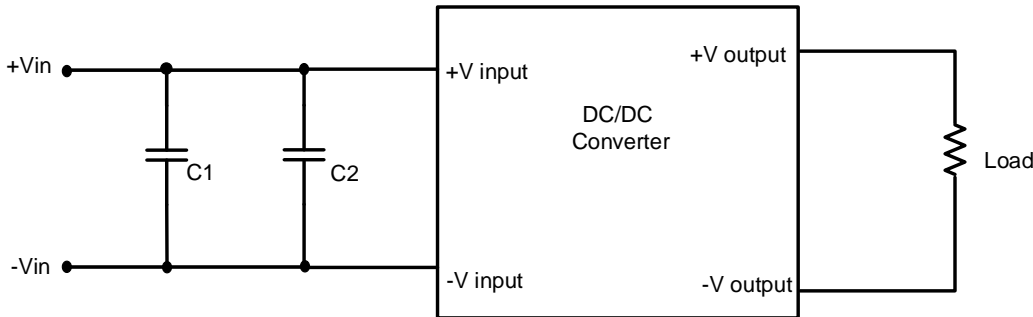

Models	C1	C2
AM8TW-24xxxH30z	330uF, 100V	-
AM8TW-110xxxH30z	100uF, 250V	100uF, 250V

**NOTE:** 1. Datasheets are updated as needed and as such, specifications are subject to change without notice. Once printed or downloaded, datasheets are no longer controlled by Aimtec; refer to [www.aimtec.com](http://www.aimtec.com) for the most current product specifications. 2. Product labels shown, including safety agency certifications on labels, may vary based on the date manufactured. 3. Mechanical drawings and specifications are for reference only. 4. All specifications are measured at an ambient temperature of 25°C, humidity<75%, nominal input voltage and at rated output load unless otherwise specified. 5. Aimtec may not have conducted destructive testing or chemical analysis on all internal components and chemicals at the time of publishing this document. CAS numbers and other limited information are considered proprietary and may not be available for release. 6. This product is not designed for use in critical life support systems, equipment used in hazardous environments, nuclear control systems or other such applications which necessitate specific safety and regulatory standards other the ones listed in this datasheet. 7. Warranty is in accordance with Aimtec's standard Terms of Sale available at [www.aimtec.com](http://www.aimtec.com).