

# Scantech ID MCR14 CCD scanner User`s Manual

## TABLE OF CONTENTS

A. General Description .....	1
B. Physical Characteristics.....	2
C. Test Board Overview .....	3
D. Electrical Characteristics .....	3
E. Performance.....	4
F. Environmental .....	4
G. Readable Symbologies .....	5
H. Decoder Data Output Connector.....	6
I. Scan Map.....	7
J. Reliability .....	7

Due to Champtek's / Scantech ID's continuing product improvement programs, specifications and features are subject to change without notice.

## A. General Description

The MCR Series brings the benefits of bar code scanning to a variety of OEM devices.



The MCR Series Scan Module is a perfect choice for your OEM design. The MCR Series brings the benefits of bar code scanning to all types of OEM devices. Now kiosks, medical instruments, diagnostic equipment, lottery terminals, vending machines and countless other appliances can all be equipped with the leading-edge scanning technology and reliability.

The MCR Series has been designed to provide the highest scanning performance in the smallest package possible. For added versatility, allowing for fast, cost-effective interchangeability when upgrading or modifying your OEM device for specialized applications.

MCR14 is a compact long-range CCD bar code scanning module with high sensitive linear image sensor. As remote-operation ability 10,000 LUX ambient light resistance, 500 scan-rate per second and aiding in various major bar codes, hand-on software-programming function, this MCR14 is your best choice of CCD type bar code scanning module to be suitable for application where needs a high performance, small foot-print and the reliable operation.

MCR14 is a CCD bar code decoding capabilities. MCR14 decode board is powered by a fast processor and to decode a wide array of 1D bar codes. The decode board is compatible with Utility, a PC-based software for easy Configuration.

The MCR14 is designed with the industrial standard size, mounting options and output to facilitate integration into existing applications. The Scanner module's miniature size makes MCR14 ideal for integration into data terminals and other small devices. MCR14 is supplied as an assembled module with a mounting bracket or as separate components for custom mounting. The scanner module's unique open system architecture allows MCR14 to accept third party and custom plug-ins, giving the MCR14 virtually unlimited application flexibility.

**Pb-Free (RoHS Compliant).**

## B. Physical Characteristics

Weight	
Body weight	Approx. 0.56 oz ( 17 g )
Material	
	Polycarbonate
Connector	
	FPC 12pin Pitch 0.5
Dimension	
	11.5mm H x 20mm W x 25mm D (REF)

### Mechanical drawing

Unit : mm

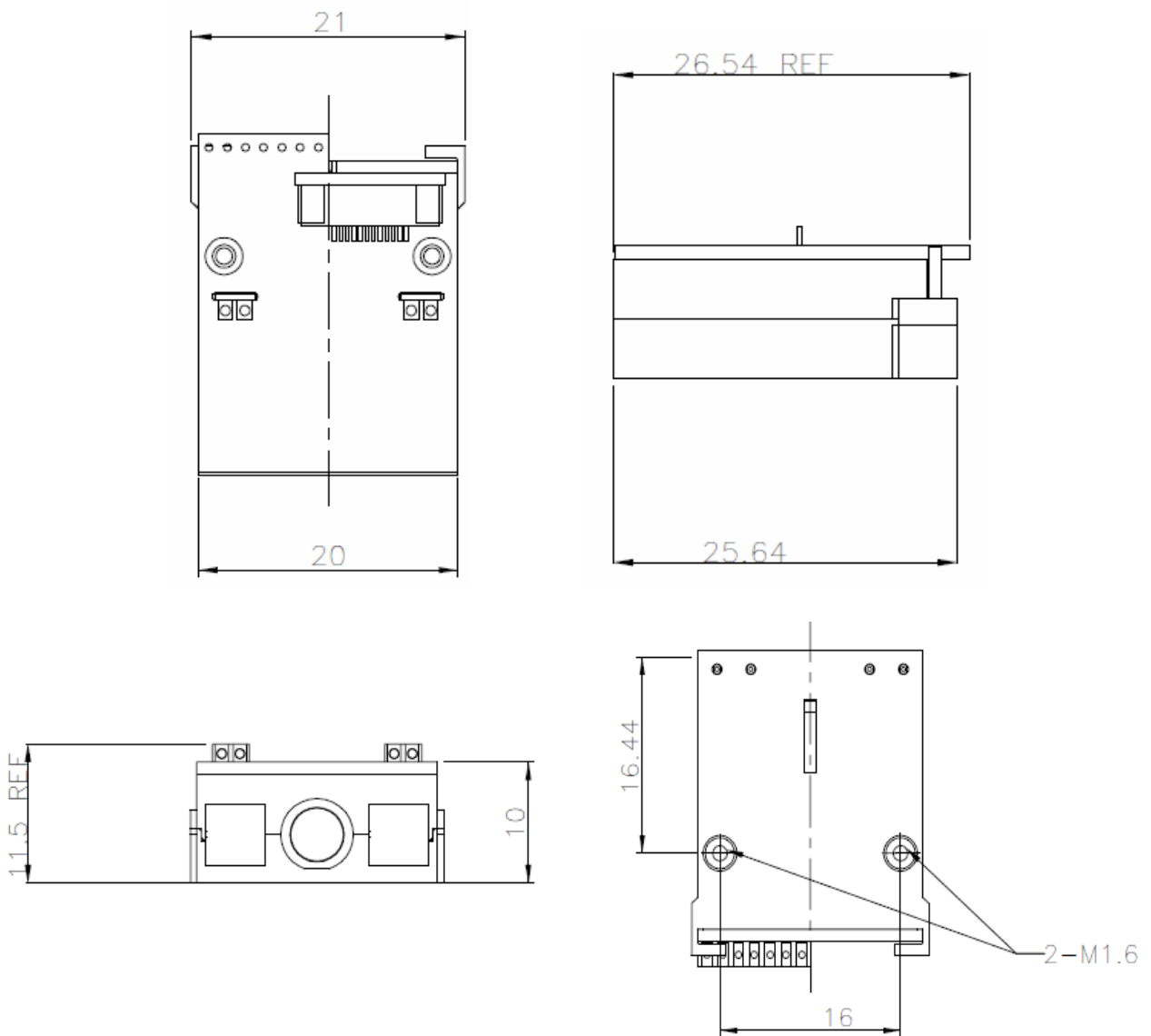

Unit : mm

### C. Test Board Overview

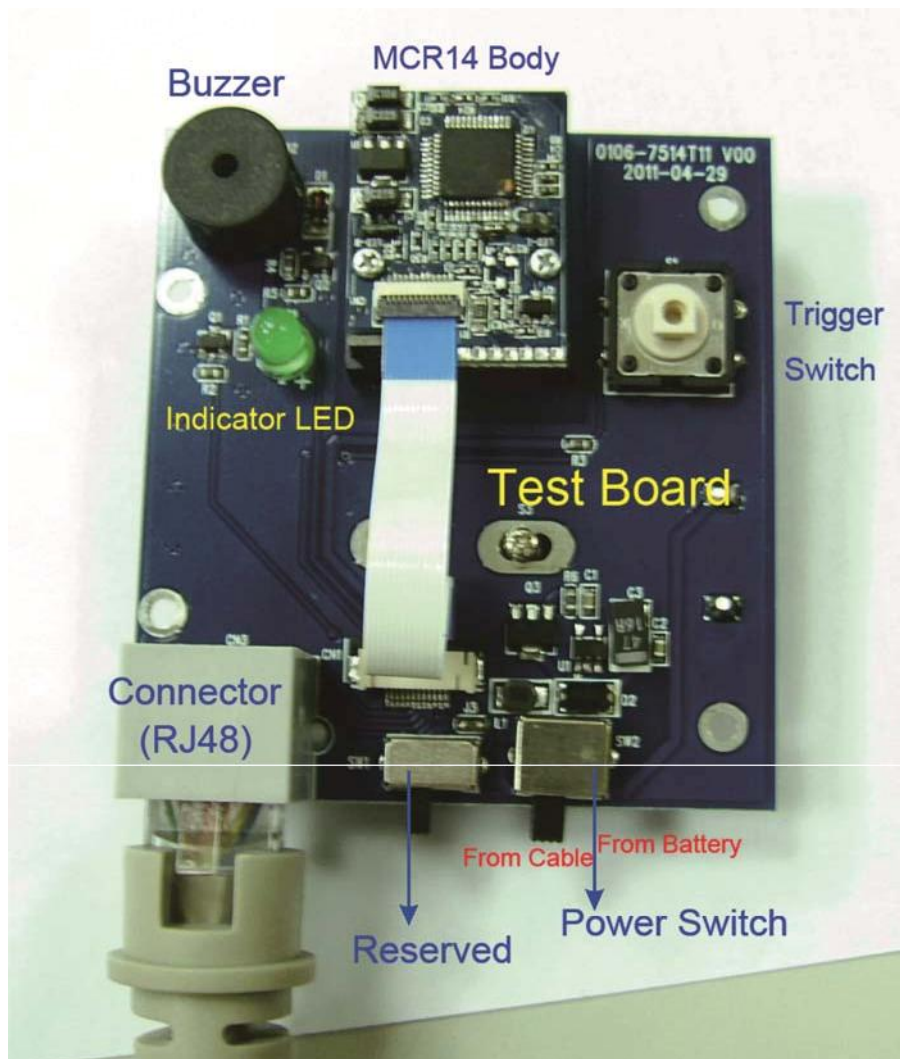

### D. Electrical Characteristics

Interface	RS232	KB	USB
Supply Voltage		DC +5V $\pm$ 5%	
Output Voltage (Typ.)	$\pm$ 9V	+5V $\pm$ 5%	+5V $\pm$ 5%
Output low Voltage (Max.)		0.7V	
Current Draw		$\pm$ 10%	
Power On (Typ.)	170mA	170mA	170mA
Stand by (Typ.)	50mA	50mA	50mA
Operation (Typ.)	150mA	150mA	150mA

## E. Performance

Light Source	Visible Red light 632nm LED
Sensor	Linear CCD Sensor
Processor Type	ARM Cortex™-M3, 32-bit
Operating Freq.	8 MHz (Internal)
Scan Rate	Smart detect up to 500 scans/second
Reading Distance	500mm@20mil/0.5mm, PCS90%
Print Contrast Ratio	PCS45%@4mil/0.1mm
Resolution	4mil/0.1mm@PCS90%
Reading Angle	<i>Test Conditions : Code 39, 10mil/0.25mm, PCS90%</i>
Pitch Angle	5°~60° (±5°)
Skew Tolerance	5°~60° (±5°)
Ambient Light	10,000 Lux Max.

## F. Environmental

Operating Temperature	0 °C to 50 °C (32 °F to 122 °F)
Storage Temperature	-20 °C to 70 °C (-4 °F to 158 °F)
Relative Humidity	20% to 95% (Non-condensing)

## G. Readable Symbologies

	Readable	Default Enable
All UPC/EAN/JAN	V	V
EAN128 Code	V	
Code 39	V	V
Code 39 Full ASCII	V	
Code32 / Italian Pharmacy	V	
Code 128	V	V
CODABAR/NW7	V	V
Interleave 25	V	V
Industrial 25	V	
Matrix 25	V	
MSI/PLESSEY	V	
Telepen	V	
Code 93	V	
Code 11	V	
China Postage	V	
Code 26	V	
LCD25	V	
GS1 DataBar	V	
GS1 DataBar Stacked	V	

## H. Decoder Data Output Connector

Type	FPC 12pin Pitch 0.5
Pin No.	Function
1	TG
2	AIM WAKEUP(Reserved)
3	GREEN LED
4	BZ
5	POWER DOWN(Reserved)
6	RTS
7	CTS
8	TXD
9	RXD
10	GND
11	VCC
12	Reserved

**I. Scan Map**

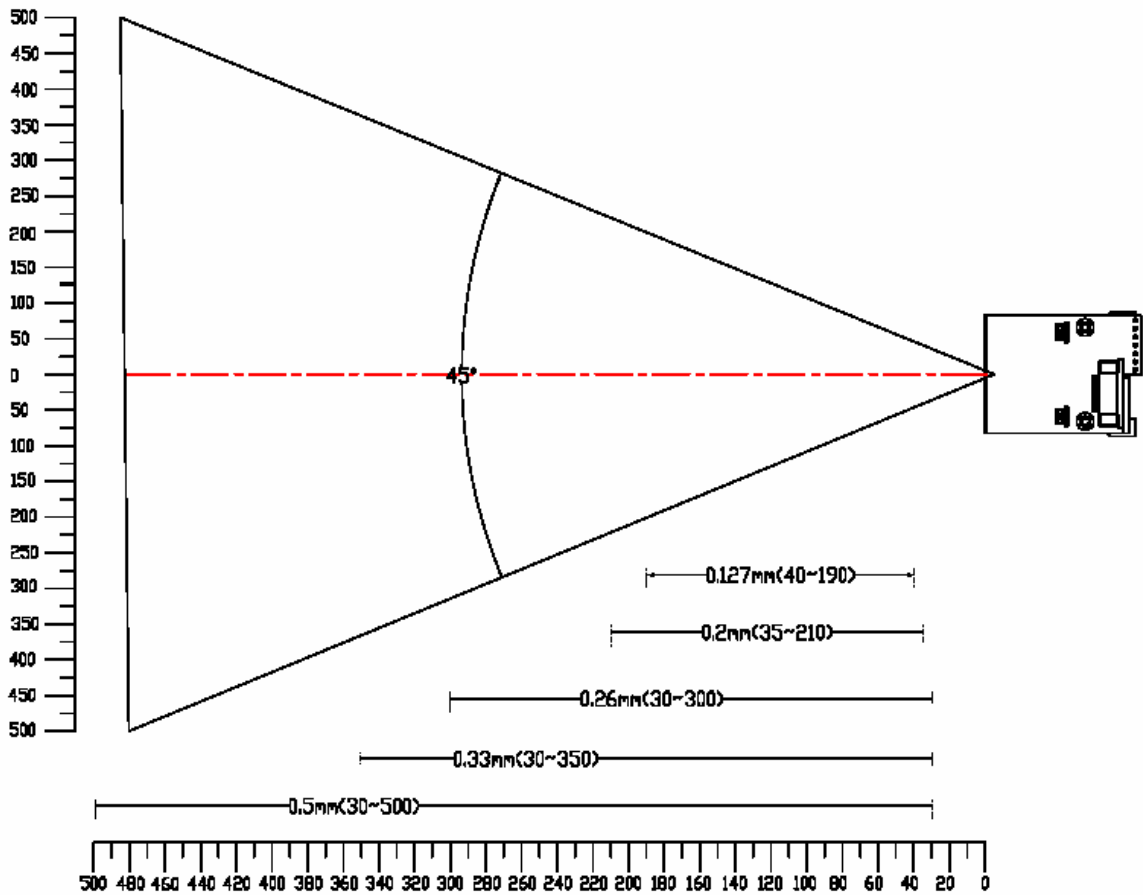

**J. Reliability**

<b>Life Time</b>	
Light Source	40,000 hours
MTBF(Calculated)	80,000 hours
<b>Thermal Shock</b>	
High Temp.	60 °C (140 °F)
Low Temp.	-20 °C (-4 °F)
Cycle time	30 minutes for high temp. , 30 minutes for low temp.
Cycles	24 cycles
<b>Mechanical Shock</b>	2000G, 0.7ms, 3 axes