



DC COMPONENTS CO., LTD.
RECTIFIER SPECIALISTS

**BY296
THRU
BY299**

TECHNICAL SPECIFICATIONS OF FAST RECOVERY RECTIFIER

VOLTAGE RANGE - 100 to 800 Volts

CURRENT - 2.0 Amperes

FEATURES

- * Fast switching
- * Low leakage
- * Low forward voltage drop
- * High current capability
- * High current surge
- * High reliability

MECHANICAL DATA

- * Case: Molded plastic
- * Epoxy: UL 94V-0 rate flame retardant
- * Lead: MIL-STD-202E, Method 208 guaranteed
- * Mounting position: Any
- * Weight: 0.38 gram



DO-15

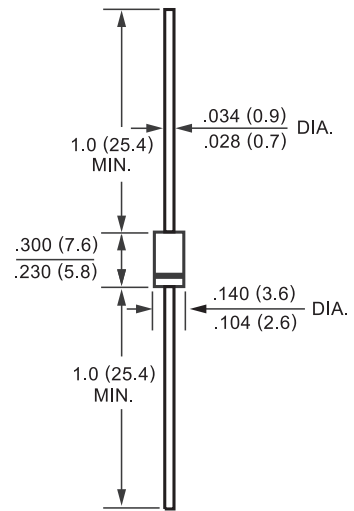

Dimensions in inches and (millimeters)

MAXIMUM RATINGS AND ELECTRICAL CHARACTERISTICS

Ratings at 25 °C ambient temperature unless otherwise specified.
Single phase, half wave, 60 Hz, resistive or inductive load.
For capacitive load, derate current by 20%.

	SYMBOL	BY296	BY297	BY298	BY299	UNITS
Maximum Recurrent Peak Reverse Voltage	V _{RRM}	100	200	400	800	Volts
Maximum RMS Voltage	V _{RMS}	70	140	280	560	Volts
Maximum DC Blocking Voltage	V _{DC}	100	200	400	800	Volts
Maximum Average Forward Rectified Current at T _A = 75°C	I _O	2.0				Amps
Peak Forward Surge Current 8.3 ms single half sine-wave superimposed on rated load (JEDEC Method)	I _{FSM}	70				Amps
Maximum Instantaneous Forward Voltage at 2.0A DC	V _F	1.3				Volts
Maximum DC Reverse Current at Rated DC Blocking Voltage T _A = 25°C	I _R	5.0				uAmps
Maximum Full Load Reverse Current Full Cycle Average, .375*(9.5mm) lead length at T _L = 55°C		100				uAmps
Maximum Reverse Recovery Time (Note 1)	t _{rr}	150			500	nSec
Typical Junction Capacitance (Note 2)	C _J	40				pF
Operating and Storage Temperature Range	T _J , T _{STG}	-65 to + 150				°C

NOTES : 1. Test Conditions: I_F = 0.5A, I_R = 1.0A, I_{RR} = 0.25A
2. Measured at 1 MHz and applied reverse voltage of 4.0 volts

RATING AND CHARACTERISTIC CURVES (BY296 THRU BY299)

FIG. 1 - TYPICAL FORWARD CURRENT DERATING CURVE

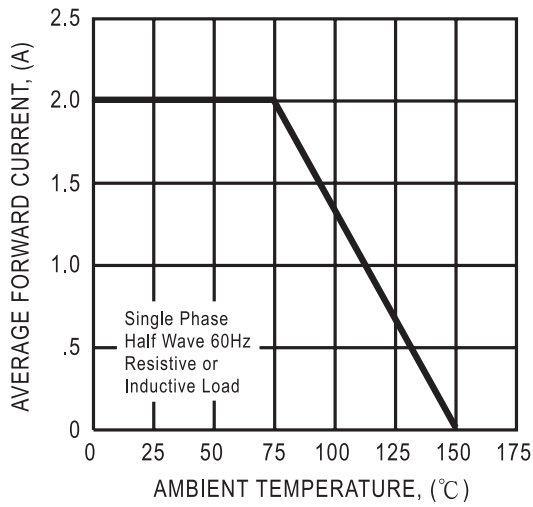

FIG. 2 - MAXIMUM NON-REPETITIVE FORWARD SURGE CURRENT

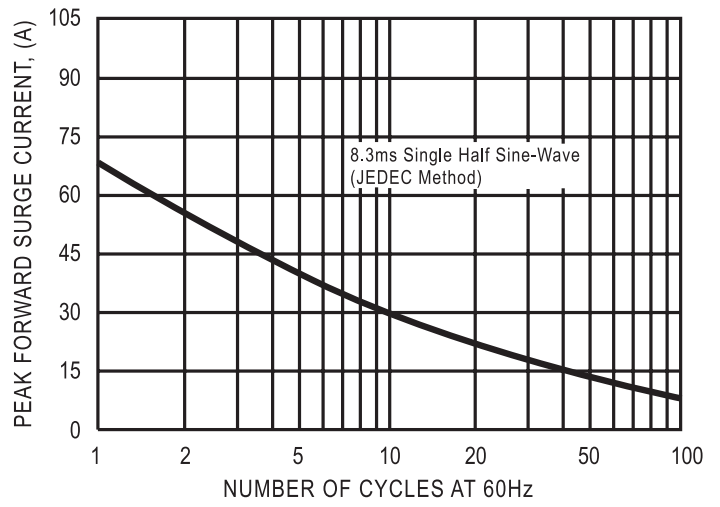

FIG. 3 - TYPICAL INSTANTANEOUS FORWARD CHARACTERISTICS

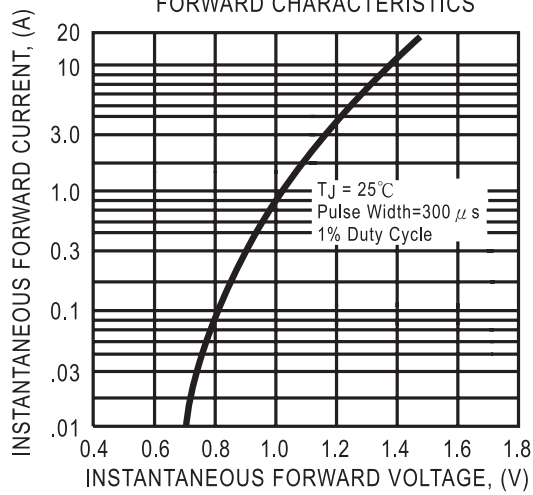

FIG. 4 - TYPICAL JUNCTION CAPACITANCE

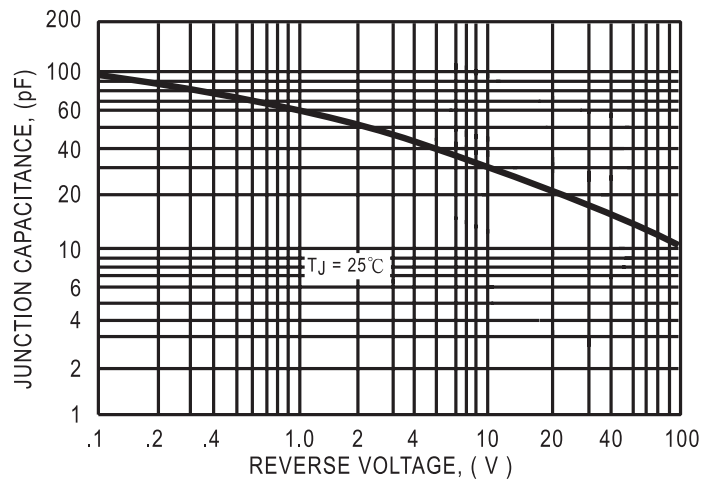
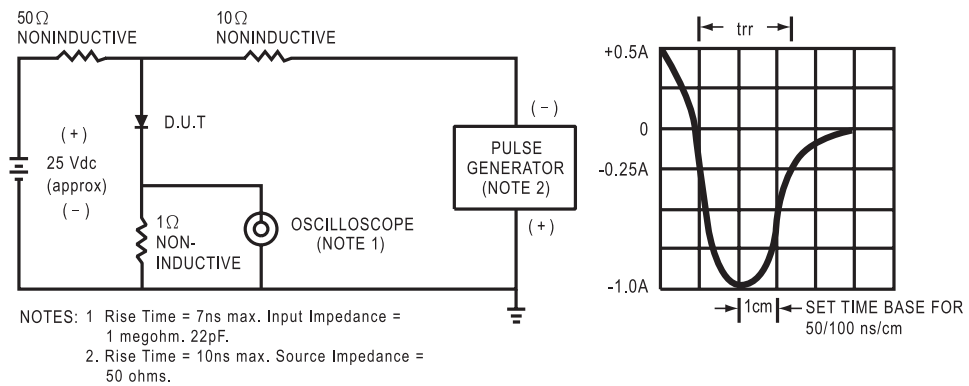

FIG. 5 - TEST CIRCUIT DIAGRAM AND REVERSE RECOVERY TIME CHARACTERISTIC



DC COMPONENTS CO., LTD.