

RECEPTACLES

PANEL MOUNTED

DBP

BODY STYLE

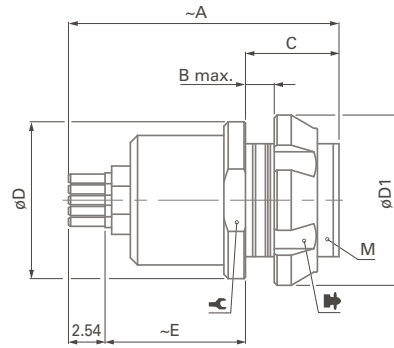

DBPU/DBPE

BODY STYLES

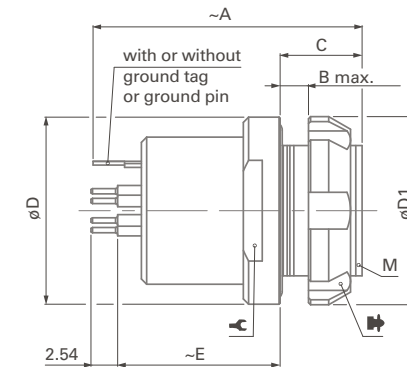

Series	A	B max.	C	D	D1	E	M	⌀	⌀ ¹⁾	Torque [Nm]
102	20	3.5	6.5	11	12	10.0	9x0.5	10	TC00.000	1.3
103	23	4.0	8.0	14	15	12.0	12x1	-	TF00.001	2.5
1031	23	3.0	7.0	16	18	13.0	14x1	-	TG00.001	3.0
104	26	5.0	9.0	19	19	11.5	15x1	-	TK00.000	4.0
105	30	12.0	17.0	22	23	10.0	18x1	-	TP00.011	6.0
106	Please contact us for additional information									
107										

Series	A	B max.	C	D	D1	E	M	⌀	⌀ ¹⁾	Torque [Nm]
102	20	3.5	6.5	14	12	11.5	9x0.5	11	TC00.000	1.3
103	26	3.0	7.8	18	18	15.5	14x1	15	TG00.001	3.0
1031	23	3.0	7.0	19	18	13.0	14x1	15	TG00.001	3.0
104	26	4.0	8.0	22	20	15.5	16x1	17	TK00.002	4.5
105	30	5.0	10.0	27	25	18.0	20x1	-	TP00.005	6.5
106	Please contact us for additional information									
107										

¹⁾ Assembly tool for decorative slotted nut, see Tooling section, page B 6-20, for details.

Torque [Nm] are recommended values that may be influenced by the quality of the panel surface under the nut. Tests have to be made to evaluate the exact values.