

# 16K-bit TTL bipolar PROM (2048 x 8)

# 82S191/82S191A

## DESCRIPTION

The 82S191 and 82S191A are field programmable, which means that custom patterns are immediately available by following the Signetics Generic I fusing procedure. The 82S191 and 82S191A are supplied with all outputs at logical Low. Outputs are programmed to a logic High level at any specified address by fusing the Ni-Cr link matrix.

These devices include on-chip decoding and 3 Chip Enable inputs for ease of memory expansion. They feature 3-State outputs for optimization of word expansion in bused organizations.

Ordering information can be found on the following page.

The 82S191 and 82S191A devices are also processed to military requirements for operation over the military temperature range. For specifications and ordering information, consult the Signetics Military Data Handbook.

## FEATURES

- Address access time:
  - N82S191: 80ns max
  - N82S191A: 55ns max
- Power dissipation: 40μW/bit typ
- Input loading: -100μA max
- Three Chip Enable inputs
- On-chip address decoding
- No separate fusing pins
- Unprogrammed outputs are Low level
- Fully TTL compatible
- Outputs: 3-State

## APPLICATIONS

- Sequential controllers
- Microprogramming
- Hardwired algorithms
- Control store
- Random logic
- Code conversion

## PIN CONFIGURATIONS

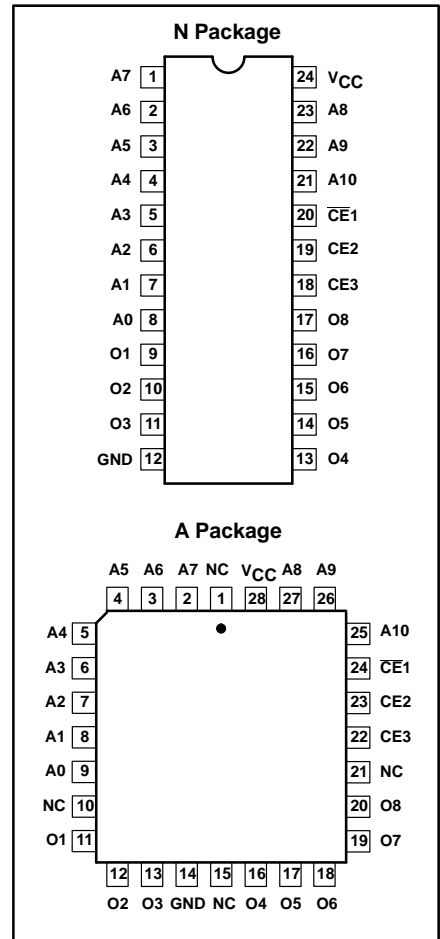

## BLOCK DIAGRAM

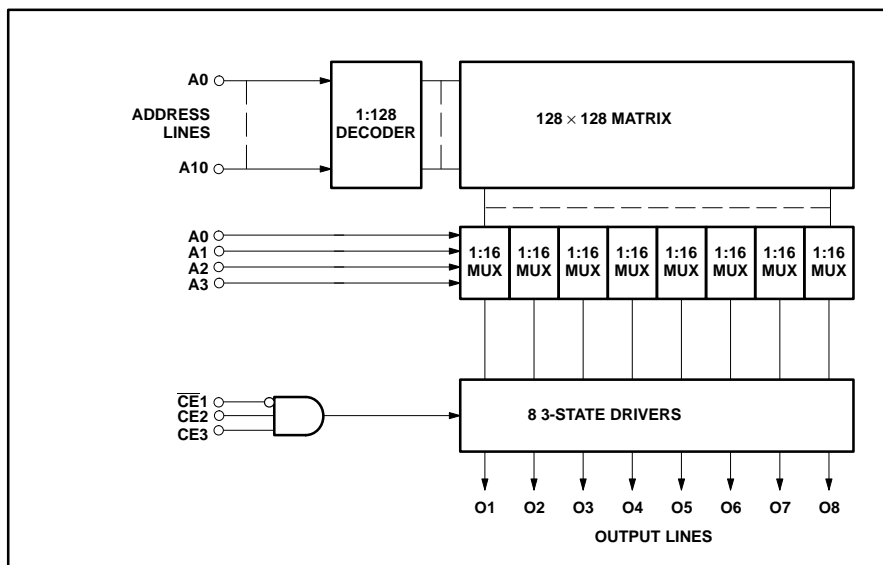

## 16K-bit TTL bipolar PROM (2048 x 8)

82S191/82S191A

## ORDERING INFORMATION

DESCRIPTION	ORDER CODE
24-Pin Plastic Dual-In-Line 600mil-wide	N82S191 N, N82S191A N
28-Pin Plastic Leaded Chip Carrier 450mil-square	N82S191 A, N82S191A A

## ABSOLUTE MAXIMUM RATINGS

SYMBOL	PARAMETER	RATING	UNIT
$V_{CC}$	Supply voltage	+7.0	$V_{DC}$
$V_{IN}$	Input voltage	+5.5	$V_{DC}$
$V_O$	Output voltage Off-State	+5.5	$V_{DC}$
$T_{amb}$	Operating temperature range	0 to +75	°C
$T_{stg}$	Storage temperature range	-65 to +150	°C

## DC ELECTRICAL CHARACTERISTICS

 $0^{\circ}\text{C} \leq T_{amb} \leq +75^{\circ}\text{C}$ ,  $4.75\text{V} \leq V_{CC} \leq 5.25\text{V}$ 

SYMBOL	PARAMETER	TEST CONDITIONS <sup>1, 2</sup>	LIMITS			UNIT
			MIN	TYP <sup>3</sup>	MAX	
<b>Input voltage</b>						
$V_{IL}$	Low	$I_{IN} = -12\text{mA}$	2.0	-0.8	0.8	V
$V_{IH}$	High				-1.2	V
$V_{IC}$	Clamp				-1.2	V
<b>Output voltage</b>						
$V_{OL}$	Low	$\overline{CE}1 = \text{Low}, CE2,3 = \text{High}$ $I_{OUT} = 9.6\text{mA}$ $I_{OUT} = -2.0\text{mA}$	2.4		0.45	V
$V_{OH}$	High				0.45	V
<b>Input current<sup>1</sup></b>						
$I_{IL}$	Low	$V_{IN} = 0.45\text{V}$ $V_{IN} = 5.5\text{V}$			-100	$\mu\text{A}$
$I_{IH}$	High				40	$\mu\text{A}$
<b>Output current<sup>1</sup></b>						
$I_{OZ}$	Hi-Z state	$\overline{CE}1 = \text{High}, CE2,3 = \text{Low}, V_{OUT} = 0.5\text{V}$ $\overline{CE}1 = \text{High}, CE2,3 = \text{Low}, V_{OUT} = 5.5\text{V}$ $\overline{CE}1 = \text{Low}, CE2,3 = \text{High}, V_{OUT} = 0\text{V}$	-15		-40	$\mu\text{A}$
$I_{OS}$	Short circuit (82S123A) <sup>4</sup>				40	$\mu\text{A}$
					-70	mA
<b>Supply current<sup>5</sup></b>						
$I_{CC}$		$V_{CC} = 5.25\text{V}$		130	175	mA
<b>Capacitance</b>						
$C_{IN}$	Input	$\overline{CE}1 = \text{High}, CE2,3 = \text{Low}, V_{CC} = 5.0\text{V}$ $V_{IN} = 2.0\text{V}$ $V_{OUT} = 2.0\text{V}$			5	pF
$C_{OUT}$	Output				8	pF

## NOTES:

- Positive current is defined as into the terminal referenced.
- All voltages with respect to network ground terminal.
- Typical values are at  $V_{CC} = 5\text{V}$ ,  $T_{amb} = +25^{\circ}\text{C}$ .
- Duration of short circuit should not exceed 1 second.
- Measured with all inputs grounded and all outputs open.

# 16K-bit TTL bipolar PROM (2048 x 8)

# 82S191/82S191A

## AC ELECTRICAL CHARACTERISTICS

$R_1 = 2=470\Omega$ ,  $R_2 = 1k\Omega$ ,  $C_L = 30pF$ ,  $0^\circ C \leq T_{amb} \leq +75^\circ C$ ,  $4.75V \leq V_{CC} \leq 5.25V$

SYMBOL	PARAMETER	TO	FROM	LIMITS			LIMITS			UNIT
				MIN	TYP <sup>1</sup>	MAX	MIN	TYP <sup>1</sup>	MAX	
<b>Access time<sup>2</sup></b>										
$t_{AA}$		Output	Address		50	80		50	55	ns
$t_{CE}$		Output	Chip Enable		30	40		20	30	ns
<b>Disable time<sup>3</sup></b>										
$t_{CD}$		Output	Chip Disable		30	40		20	30	ns

**NOTES:**

1. Typical values are  $V_{CC} = 5V$ ,  $T_{amb} = +25^\circ C$ .
2. Tested at an address cycle time of  $1\mu s$ .
3. Measured at a delta of 0.5V from Logic Level with  $R_1 = 750\Omega$ ,  $R_2 = 750\Omega$  and  $C_L = 5pF$ .

## TEST LOAD CIRCUIT

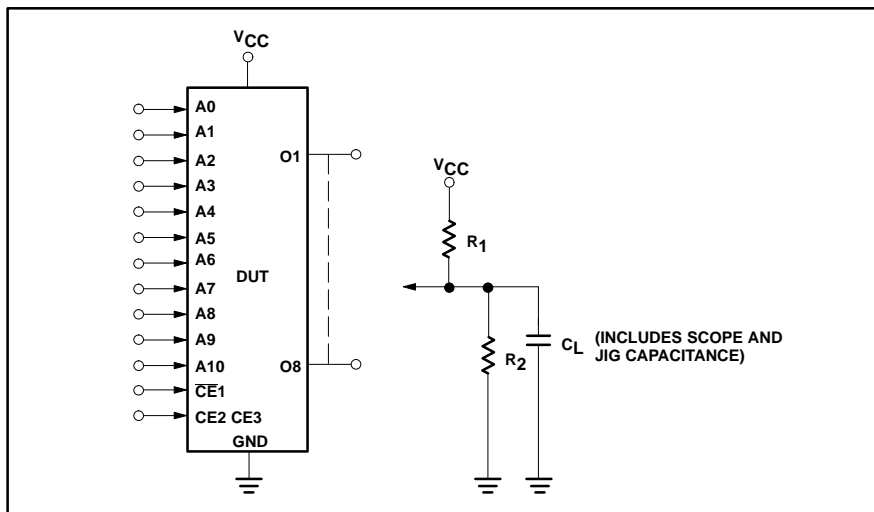

## VOLTAGE WAVEFORMS

