

SN75ALS160

OCTAL GENERAL-PURPOSE INTERFACE BUS TRANSCEIVERS

SLLS018E – JUNE 1986 – REVISED JUNE 2004

- Suitable for IEEE Standard 488-1978 (GPIB)
- 8-Channel Bidirectional Transceivers
- High-Speed Advanced Low-Power Schottky (ALS) Circuitry
- Low Power Dissipation
... 46 mW Max Per Channel
- Fast Propagation Times ... 20 ns Max
- High-Impedance pnp Inputs
- Receiver Hysteresis ... 650 mV Typ
- Open-Collector Driver Output Option
- No Loading of Bus When Device Is Powered Down ($V_{CC} = 0$)
- Power-Up/Power-Down Protection (Glitch Free)

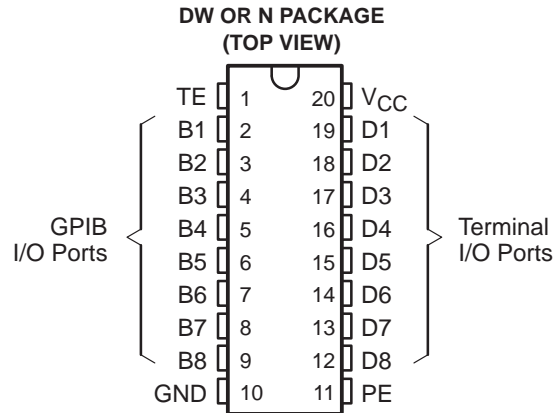

description/ordering information

The SN75ALS160 eight-channel general-purpose interface bus transceivers are monolithic, high-speed, advanced low-power Schottky (ALS) devices designed for two-way data communications over single-ended transmission lines. This device is designed to meet the requirements of IEEE Standard 488-1978. The transceivers feature driver outputs that can be operated in either the passive-pullup or 3-state mode. If talk enable (TE) is high, these ports have the characteristics of passive-pullup outputs when pullup enable (PE) is low and of 3-state outputs when PE is high. Taking TE low places these ports in the high-impedance state. The driver outputs are designed to handle loads up to 48 mA of sink current.

An active turn-off feature has been incorporated into the bus-terminating resistors so that the device exhibits a high impedance to the bus when $V_{CC} = 0$. When combined with the SN75ALS161 or SN75ALS162 bus management transceiver, the pair provides the complete 16-wire interface for the IEEE-488 bus.

The SN75ALS160 is characterized for operation from 0°C to 70°C.

ORDERING INFORMATION

| T _A | PACKAGE† | | ORDERABLE PART NUMBER | TOP-SIDE MARKING |
|----------------|-----------|--------------|-----------------------|------------------|
| 0°C to 70°C | PDIP (N) | Tube of 20 | SN75ALS160N | SN75ALS160N |
| | SOIC (DW) | Tube of 25 | SN75ALS160DW | 75ALS160 |
| | | Reel of 2000 | SN75ALS160DWR | |

† Package drawings, standard packing quantities, thermal data, symbolization, and PCB design guidelines are available at www.ti.com/sc/package.



Please be aware that an important notice concerning availability, standard warranty, and use in critical applications of Texas Instruments semiconductor products and disclaimers thereto appears at the end of this data sheet.

PRODUCTION DATA information is current as of publication date. Products conform to specifications per the terms of Texas Instruments standard warranty. Production processing does not necessarily include testing of all parameters.

**TEXAS
INSTRUMENTS**

POST OFFICE BOX 655303 • DALLAS, TEXAS 75265

Copyright © 2004, Texas Instruments Incorporated

SN75ALS160 OCTAL GENERAL-PURPOSE INTERFACE BUS TRANSCEIVERS

SLLS018E – JUNE 1986 – REVISED JUNE 2004

Function Tables

EACH DRIVER

| INPUTS | | | OUTPUT |
|--------|----|----|--------|
| D | TE | PE | B |
| H | H | H | H |
| L | H | X | L |
| H | X | L | Z† |
| X | L | X | Z† |

EACH RECEIVER

| INPUTS | | | OUTPUT |
|--------|----|----|--------|
| B | TE | PE | D |
| L | L | X | L |
| H | L | X | H |
| X | H | X | Z |

H = high level, L = low level, X = irrelevant,
Z = high-impedance state

† This is the high-impedance state of a normal 3-state output modified by the internal resistors to V_{CC} and GND.

logic diagram (positive logic)

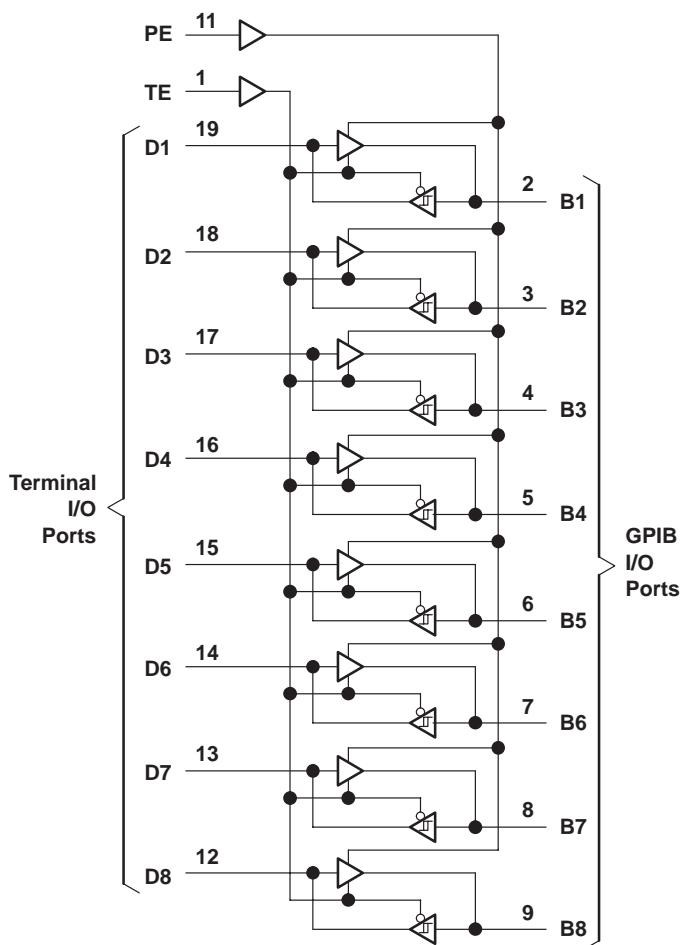

SN75ALS160 OCTAL GENERAL-PURPOSE INTERFACE BUS TRANSCEIVERS

SLLS018E – JUNE 1986 – REVISED JUNE 2004

schematics of inputs and outputs

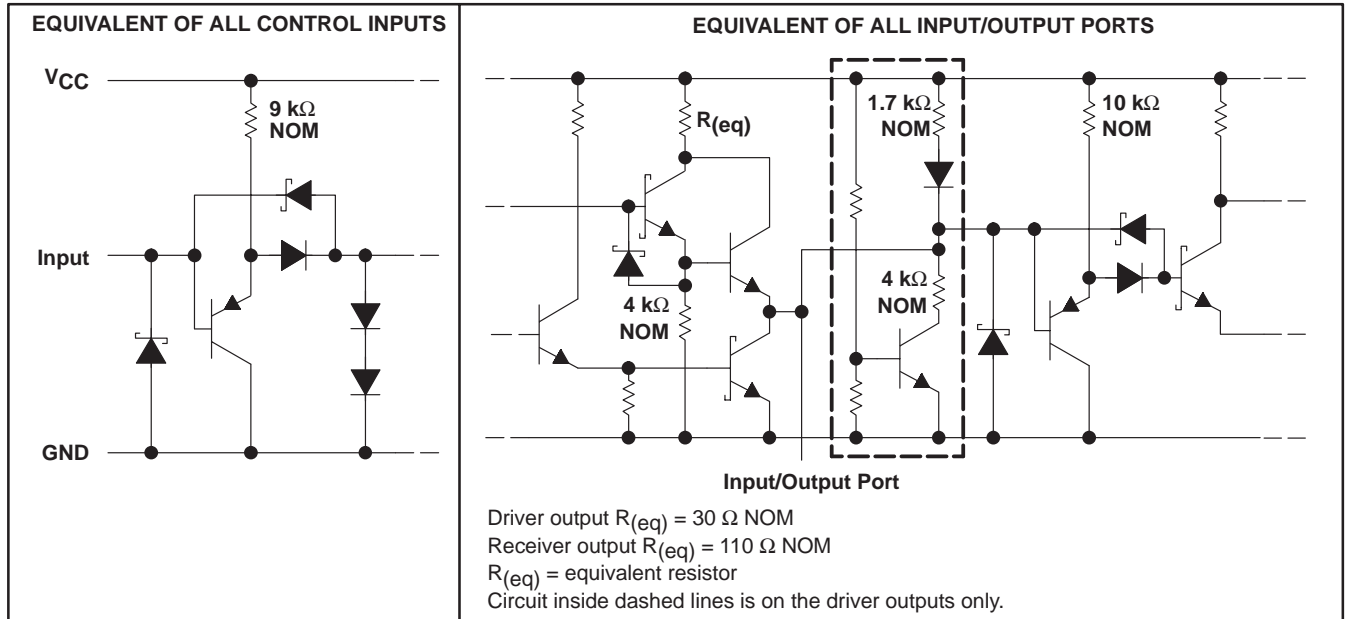

absolute maximum ratings over operating free-air temperature range (unless otherwise noted)†

| | |
|--|----------------|
| Supply voltage, V_{CC} (see Note 1) | 7 V |
| Input voltage, V_I | 5.5 V |
| Low-level driver output current, I_{OL} | 100 mA |
| Package thermal impedance, θ_{JA} (see Notes 2 and 3): DW package | 58°C/W |
| N package | 69°C/W |
| Operating virtual junction temperature, T_J | 150°C |
| Storage temperature range, T_{STG} | -65°C to 150°C |

† Stresses beyond those listed under "absolute maximum ratings" may cause permanent damage to the device. These are stress ratings only, and functional operation of the device at these or any other conditions beyond those indicated under "recommended operating conditions" is not implied. Exposure to absolute-maximum-rated conditions for extended periods may affect device reliability.

- NOTES:
- All voltage values are with respect to network ground terminal.
 - Maximum power dissipation is a function of $T_J(\text{max})$, θ_{JA} , and T_A . The maximum allowable power dissipation at any allowable ambient temperature is $P_D = (T_J(\text{max}) - T_A) / \theta_{JA}$. Operating at the absolute maximum T_J of 150°C can affect reliability.
 - The package thermal impedance is calculated in accordance with JESD 51-7.

SN75ALS160

OCTAL GENERAL-PURPOSE INTERFACE BUS TRANSCEIVERS

SLLS018E – JUNE 1986 – REVISED JUNE 2004

recommended operating conditions

| | | MIN | NOM | MAX | UNIT |
|-----------------|--------------------------------|-------------------------------|-----|------|------|
| V _{CC} | Supply voltage | 4.75 | 5 | 5.25 | V |
| V _{IH} | High-level input voltage | 2 | | | V |
| V _{IL} | Low-level input voltage | | | 0.8 | V |
| I _{OH} | High-level output current | Bus ports with pullups active | | -5.2 | mA |
| | | Terminal ports | | -800 | μA |
| I _{OL} | Low-level output current | Bus ports | | 48 | mA |
| | | Terminal ports | | 16 | |
| T _A | Operating free-air temperature | 0 | | 70 | °C |

electrical characteristics over recommended ranges of supply voltage and operating free-air temperature (unless otherwise noted)

| PARAMETER | | TEST CONDITION [†] | | MIN | TYP [‡] | MAX | UNIT | | |
|------------------------------|---|--|--|---------------------------------------|------------------|------|------|------|------|
| V _{IK} | Input clamp voltage | I _I = -18 mA, V _{CC} = MIN | | -0.8 | -1.5 | | V | | |
| V _{hys} | Hysteresis voltage (V _{IT+} - V _{IT-}) | Bus | | 0.4 | 0.65 | | V | | |
| V _{OH} [§] | High-level output voltage | Terminal | I _{OH} = -800 μA, TE at 0.8 V, V _{CC} = MIN | 2.7 | 3.5 | | V | | |
| | | Bus | I _{OH} = -5.2 mA, PE and TE at 2 V, V _{CC} = MIN | 2.5 | 3.3 | | | | |
| V _{OL} | Low-level output voltage | Terminal | I _{OL} = 16 mA, TE at 0.8 V, V _{CC} = MIN | | 0.3 | 0.5 | V | | |
| | | Bus | I _{OL} = 48 mA, TE at 2 V, V _{CC} = MIN | | 0.35 | 0.5 | | | |
| I _I | Input current at maximum input voltage | Terminal | V _I = 5.5 V, V _{CC} = MAX | | 0.2 | 100 | μA | | |
| I _{IH} | High-level input current | Terminal, PE, or TE | V _I = 2.7 V, V _{CC} = MAX | | 0.1 | 20 | μA | | |
| I _{IL} | Low-level input current | Terminal, PE, or TE | V _I = 0.5 V, V _{CC} = MAX | | -10 | -100 | μA | | |
| V _{I/O(bus)} | Voltage at bus port | I _{I(bus)} = 0 | | 2.5 | 3 | 3.7 | V | | |
| | | I _{I(bus)} = -12 mA | | | | -1.5 | V | | |
| I _{I/O(bus)} | Current into bus port | Power on | V _{CC} = MAX | V _{I(bus)} = -1.5 V to 0.4 V | | -1.3 | mA | | |
| | | | | V _{I(bus)} = 0.4 V to 2.5 V | | 0 | | -3.2 | |
| | | | | V _{I(bus)} = 2.5 V to 3.7 V | | | | 2.5 | -3.2 |
| | | | | V _{I(bus)} = 3.7 V to 5 V | | 0 | | 2.5 | |
| | | | | V _{I(bus)} = 5 V to 5.5 V | | 0.7 | | 2.5 | |
| | | Power off | V _{CC} = 0 | V _{I(bus)} = 0 to 2.5 V | | | | 40 | μA |
| I _{OS} | Short-circuit output current | Terminal | V _{CC} = MAX | | -15 | -35 | -75 | mA | |
| | | Bus | V _{CC} = MAX | | -25 | -50 | -125 | | |
| I _{CC} | Supply current | No load, V _{CC} = MAX | Terminal outputs low and enabled | | 42 | 65 | mA | | |
| | | | Bus outputs low and enabled | | 52 | 80 | | | |
| C _{I/O(bus)} | Bus-port capacitance | V _{CC} = 0 to 5 V, V _{I/O} = 0 to 2 V, f = 1 MHz | | 30 | | | pF | | |

[†] For conditions shown as MIN or MAX, use the appropriate value specified under recommended operating conditions.

[‡] All typical values are at V_{CC} = 5 V, T_A = 25°C.

[§] V_{OH} applies to 3-state outputs only.



SN75ALS160

OCTAL GENERAL-PURPOSE INTERFACE BUS TRANSCEIVERS

SLLS018E – JUNE 1986 – REVISED JUNE 2004

switching characteristics at $V_{CC} = 4.75\text{ V}$, 5 V , and 5.25 V , $T_A = 25^\circ\text{C}$ (unless otherwise noted)

| PARAMETER | FROM (INPUT) | TO (OUTPUT) | TEST CONDITIONS | MIN | TYP† | MAX | UNIT |
|--|--------------|-------------|------------------------------------|-----|------|-----|------|
| t _{PLH} Propagation delay time, low- to high-level output | Terminal | Bus | See Figure 1, $C_L = 50\text{ pF}$ | | 10 | 17 | ns |
| t _{PHL} Propagation delay time, high- to low-level output | | | | | 10 | 14 | |
| t _{PLH} Propagation delay time, low- to high-level output | Bus | Terminal | See Figure 2, $C_L = 50\text{ pF}$ | | 8 | 15 | ns |
| t _{PHL} Propagation delay time, high- to low-level output | | | | | 8 | 15 | |
| t _{PZH} Output enable time to high level | TE | Bus | See Figure 3, $C_L = 50\text{ pF}$ | | 24 | 30 | ns |
| t _{PHZ} Output disable time from high level | | | | | 9 | 14 | |
| t _{PZL} Output enable time to low level | | | | | 16 | 28 | |
| t _{PLZ} Output disable time from low level | | | | | 12 | 19 | |
| t _{PZH} Output enable time to high level | TE | Terminal | See Figure 4, $C_L = 50\text{ pF}$ | | 24 | 36 | ns |
| t _{PHZ} Output disable time from high level | | | | | 10 | 18 | |
| t _{PZL} Output enable time to low level | | | | | 15 | 26 | |
| t _{PLZ} Output disable time from low level | | | | | 15 | 24 | |
| t _{en} Output pullup enable time | PE | Bus | See Figure 5, $C_L = 50\text{ pF}$ | | 16 | 24 | ns |
| t _{dis} Output pullup disable time | | | | | 9 | 16 | |

† All typical values are at $V_{CC} = 5\text{ V}$.

switching characteristics over recommended range of operating free-air temperature, $V_{CC} = 5\text{ V}$

| PARAMETER | FROM (INPUT) | TO (OUTPUT) | TEST CONDITIONS | MIN | TYP‡ | MAX | UNIT |
|--|--------------|-------------|--|-----|------|-----|------|
| t _{PLH} Propagation delay time, low- to high-level output | Terminal | Bus | $C_L = 30\text{ pF}$, See Figure 1 | | 7 | 20 | ns |
| t _{PHL} Propagation delay time, high- to low-level output | | | | | 8 | 20 | |
| t _{PLH} Propagation delay time, low- to high-level output | Bus | Terminal | $C_L = 30\text{ pF}$, See Figure 2 | | 7 | 14 | ns |
| t _{PHL} Propagation delay time, high- to low-level output | | | | | 9 | 14 | |
| t _{PZH} Output enable time to high level | TE | Bus | $C_L = 15\text{ pF}$, See Figure 3 | | 19 | 30 | ns |
| t _{PHZ} Output disable time from high level | | | | | 5 | 12 | |
| t _{PZL} Output enable time to low level | | | | | 16 | 35 | |
| t _{PLZ} Output disable time from low level | | | | | 9 | 20 | |
| t _{PZH} Output enable time to high level | TE | Terminal | $C_L = 15\text{ pF}$, See Figure 4 | | 13 | 30 | ns |
| t _{PHZ} Output disable time from high level | | | | | 12 | 20 | |
| t _{PZL} Output enable time to low level | | | | | 12 | 20 | |
| t _{PLZ} Output disable time from low level | | | | | 11 | 20 | |
| t _{en} Output pullup enable time | PE | Bus | $C_L = 15\text{ pF}$, See Figure 5 | | 11 | 22 | ns |
| t _{dis} Output pullup disable time | | | | | 6 | 12 | |

‡ Typical values are at $T_A = 25^\circ\text{C}$.



SN75ALS160 OCTAL GENERAL-PURPOSE INTERFACE BUS TRANSCEIVERS

SLLS018E – JUNE 1986 – REVISED JUNE 2004

PARAMETER MEASUREMENT INFORMATION

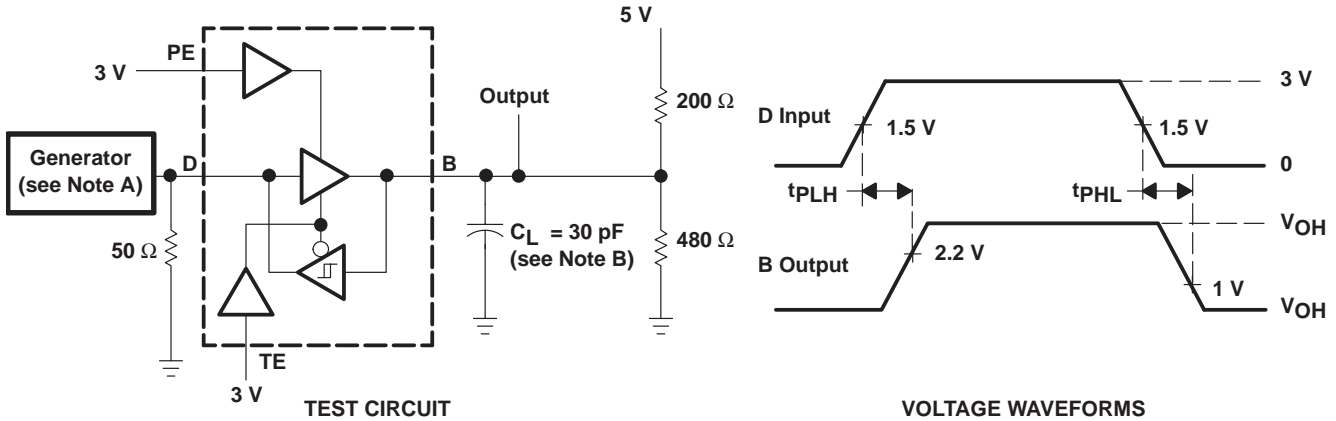

- NOTES: A. The input pulse is supplied by a generator having the following characteristics: $PRR \leq 1$ MHz, 50% duty cycle, $t_r \leq 6$ ns, $t_f \leq 6$ ns, $Z_O = 50 \Omega$.
 B. C_L includes probe and jig capacitance.

Figure 1. Terminal-to-Bus Test Circuit and Voltage Waveforms

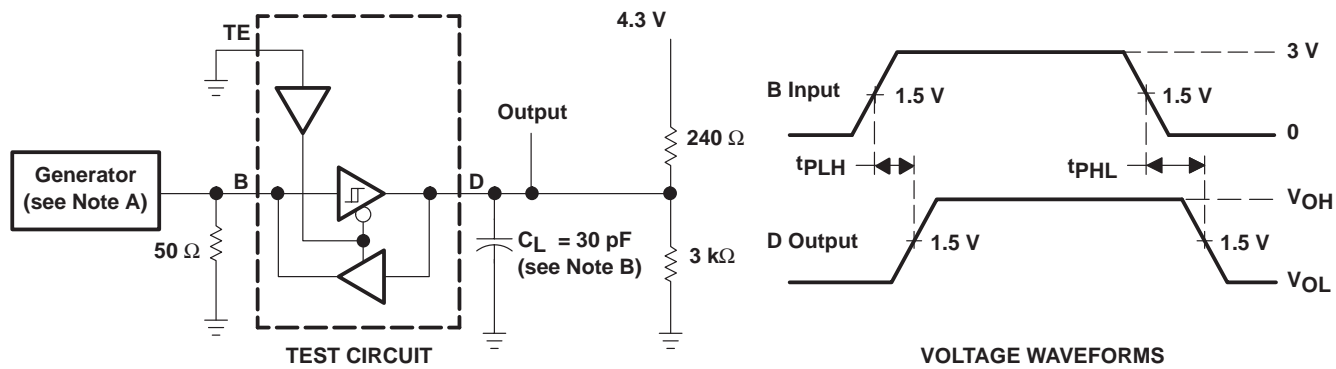

- NOTES: A. The input pulse is supplied by a generator having the following characteristics: $PRR \leq 1$ MHz, 50% duty cycle, $t_r \leq 6$ ns, $t_f \leq 6$ ns, $Z_O = 50 \Omega$.
 B. C_L includes probe and jig capacitance.

Figure 2. Bus-to-Terminal Test Circuit and Voltage Waveforms

PARAMETER MEASUREMENT INFORMATION

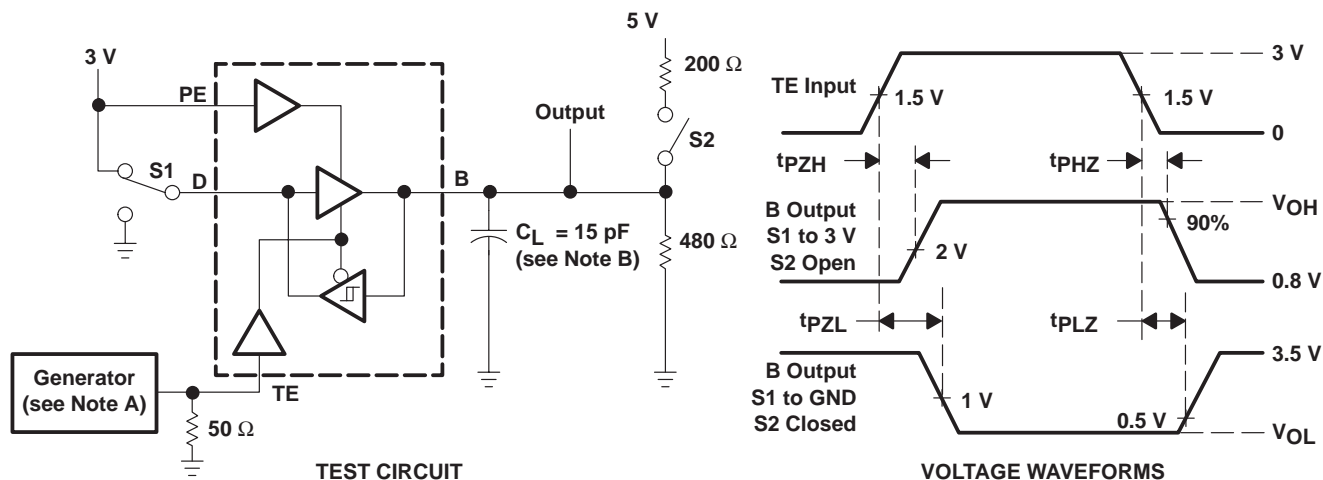

- NOTES: A. The input pulse is supplied by a generator having the following characteristics: PRR \leq 1 MHz, 50% duty cycle, $t_r \leq$ 6 ns, $t_f \leq$ 6 ns, $Z_O = 50 \Omega$.
 B. C_L includes probe and jig capacitance.

Figure 3. TE-to-Bus Test Circuit and Voltage Waveforms

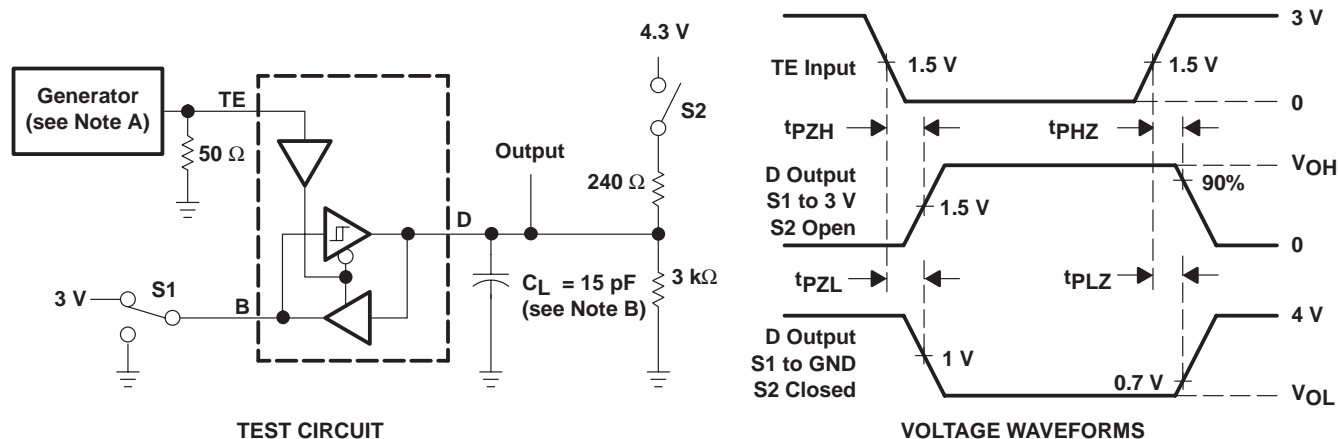

- NOTES: A. The input pulse is supplied by a generator having the following characteristics: PRR \leq 1 MHz, 50% duty cycle, $t_r \leq$ 6 ns, $t_f \leq$ 6 ns, $Z_O = 50 \Omega$.
 B. C_L includes probe and jig capacitance.

Figure 4. TE-to-Terminal Test Circuit and Voltage Waveforms

SN75ALS160 OCTAL GENERAL-PURPOSE INTERFACE BUS TRANSCEIVERS

SLLS018E – JUNE 1986 – REVISED JUNE 2004

PARAMETER MEASUREMENT INFORMATION

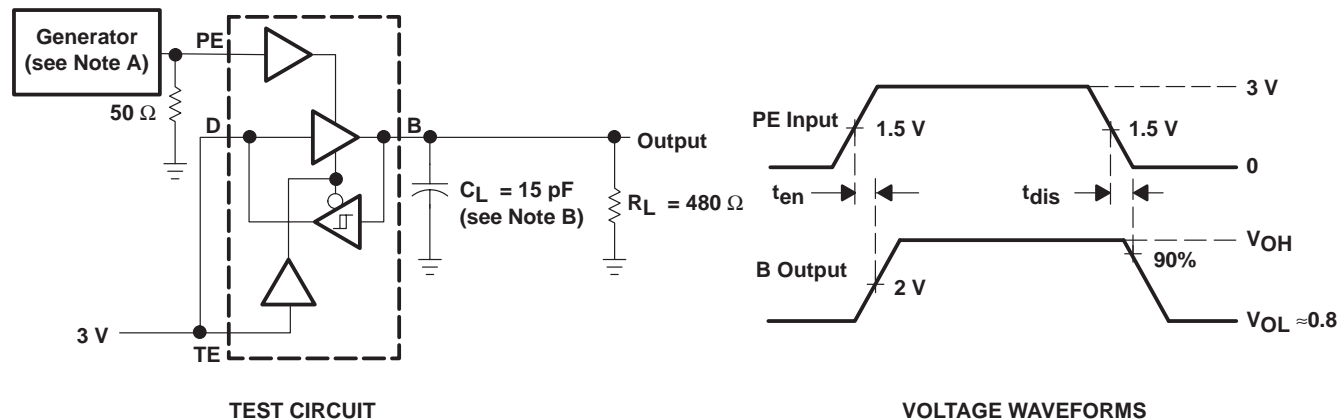

- NOTES: A. The input pulse is supplied by a generator having the following characteristics: $PRR \leq 1\text{ MHz}$, 50% duty cycle, $t_r \leq 6\text{ ns}$, $t_f \leq 6\text{ ns}$, $Z_0 = 50\ \Omega$.
 B. C_L includes probe and jig capacitance.

Figure 5. PE-to-Bus Test Circuit and Voltage Waveforms

TYPICAL CHARACTERISTICS

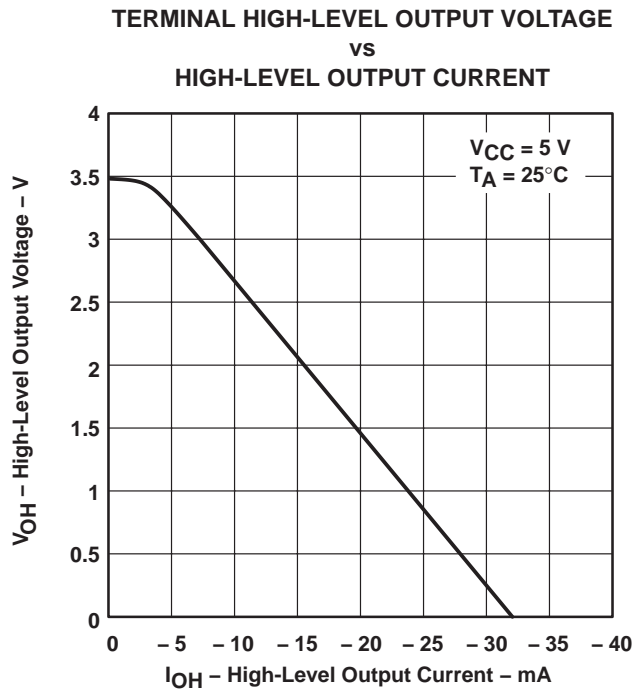

Figure 6

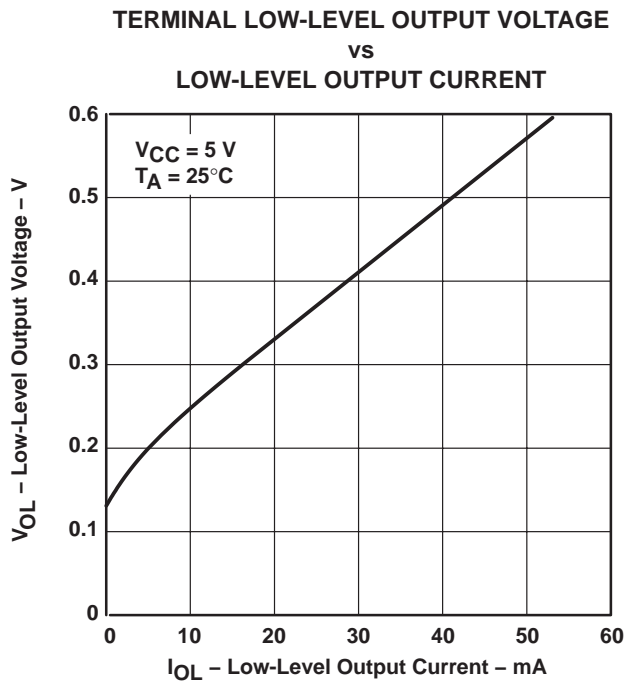

Figure 7

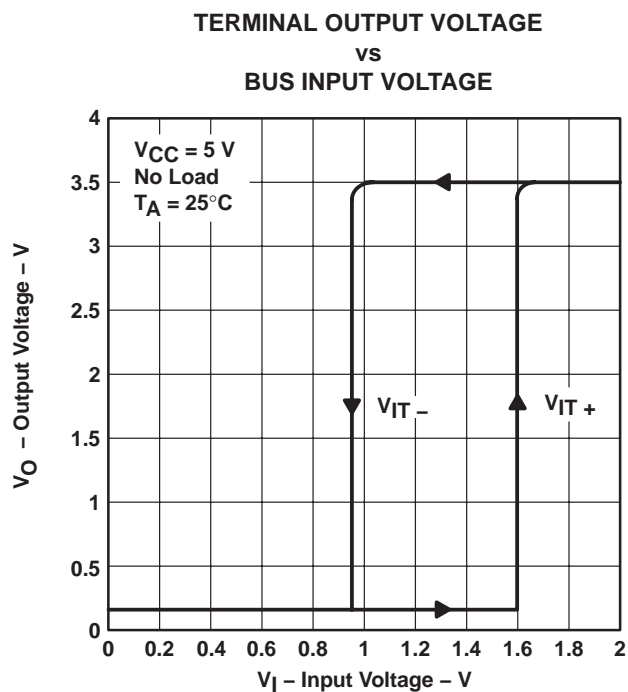

Figure 8

SN75ALS160

OCTAL GENERAL-PURPOSE INTERFACE BUS TRANSCEIVERS

SLLS018E – JUNE 1986 – REVISED JUNE 2004

TYPICAL CHARACTERISTICS

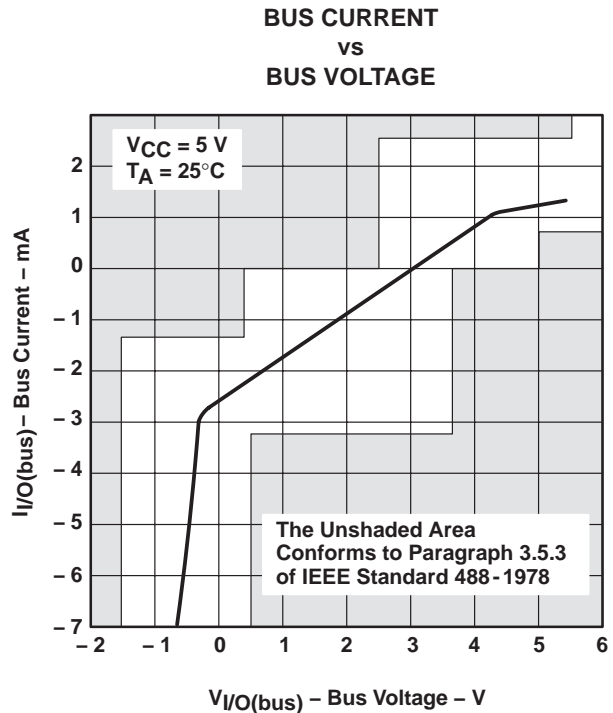
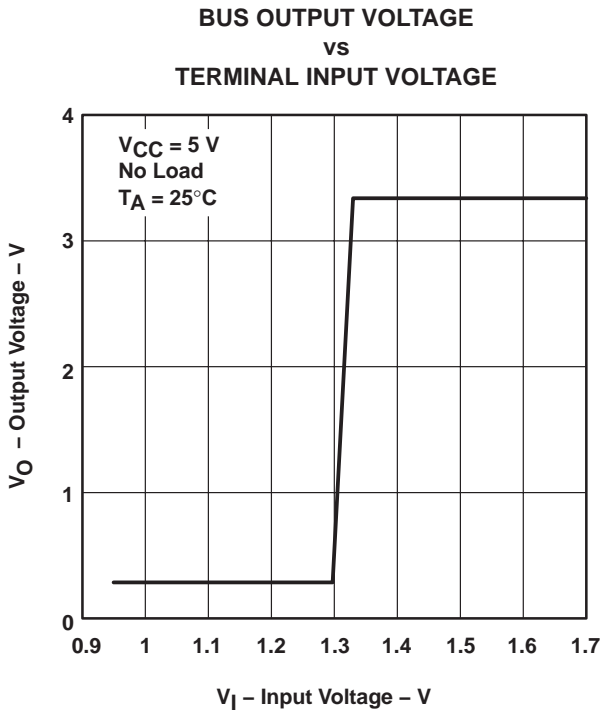
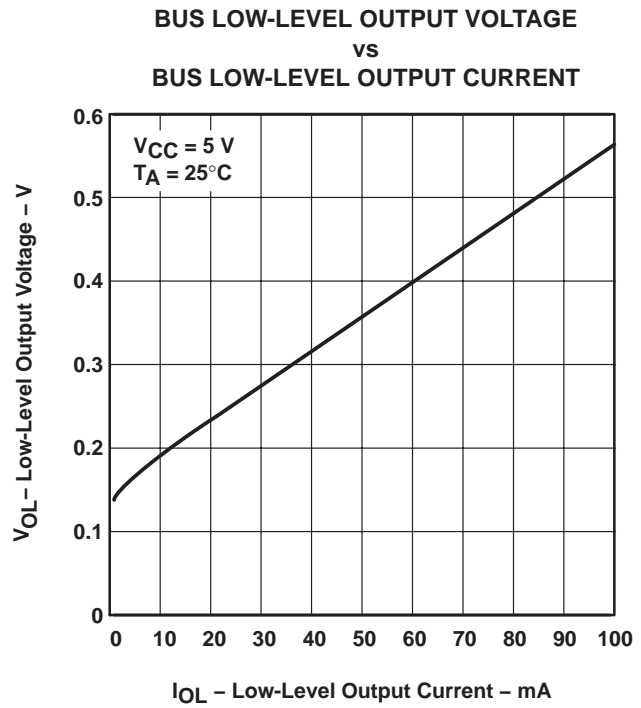
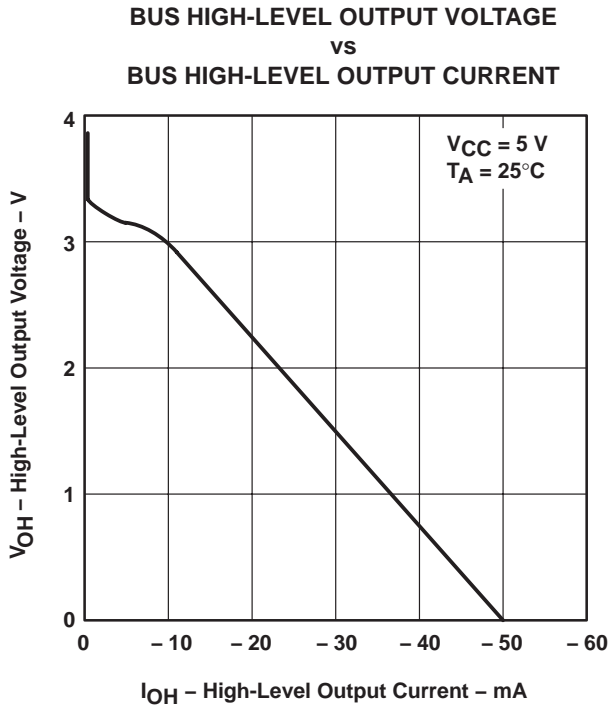

PACKAGING INFORMATION

| Orderable Device | Status (1) | Package Type | Package Drawing | Pins | Package Qty | Eco Plan (2) | Lead/Ball Finish (6) | MSL Peak Temp (3) | Op Temp (°C) | Device Marking (4/5) | Samples |
|------------------|---------------|--------------|-----------------|------|-------------|-------------------------|-------------------------|----------------------|--------------|-------------------------|-------------------------|
| SN75ALS160DW | ACTIVE | SOIC | DW | 20 | 25 | Green (RoHS & no Sb/Br) | CU NIPDAU | Level-1-260C-UNLIM | 0 to 70 | 75ALS160 | Samples |
| SN75ALS160DWE4 | ACTIVE | SOIC | DW | 20 | 25 | Green (RoHS & no Sb/Br) | CU NIPDAU | Level-1-260C-UNLIM | 0 to 70 | 75ALS160 | Samples |
| SN75ALS160DWG4 | ACTIVE | SOIC | DW | 20 | 25 | Green (RoHS & no Sb/Br) | CU NIPDAU | Level-1-260C-UNLIM | 0 to 70 | 75ALS160 | Samples |
| SN75ALS160DWR | ACTIVE | SOIC | DW | 20 | 2000 | Green (RoHS & no Sb/Br) | CU NIPDAU CU SN | Level-1-260C-UNLIM | 0 to 70 | 75ALS160 | Samples |
| SN75ALS160DWRE4 | ACTIVE | SOIC | DW | 20 | 2000 | Green (RoHS & no Sb/Br) | CU NIPDAU | Level-1-260C-UNLIM | 0 to 70 | 75ALS160 | Samples |
| SN75ALS160DWRG4 | ACTIVE | SOIC | DW | 20 | 2000 | Green (RoHS & no Sb/Br) | CU NIPDAU | Level-1-260C-UNLIM | 0 to 70 | 75ALS160 | Samples |
| SN75ALS160N | ACTIVE | PDIP | N | 20 | 20 | Pb-Free (RoHS) | CU NIPDAU | N / A for Pkg Type | 0 to 70 | SN75ALS160N | Samples |

(1) The marketing status values are defined as follows:

ACTIVE: Product device recommended for new designs.

LIFEBUY: TI has announced that the device will be discontinued, and a lifetime-buy period is in effect.

NRND: Not recommended for new designs. Device is in production to support existing customers, but TI does not recommend using this part in a new design.

PREVIEW: Device has been announced but is not in production. Samples may or may not be available.

OBSELETE: TI has discontinued the production of the device.

(2) Eco Plan - The planned eco-friendly classification: Pb-Free (RoHS), Pb-Free (RoHS Exempt), or Green (RoHS & no Sb/Br) - please check <http://www.ti.com/productcontent> for the latest availability information and additional product content details.

TBD: The Pb-Free/Green conversion plan has not been defined.

Pb-Free (RoHS): TI's terms "Lead-Free" or "Pb-Free" mean semiconductor products that are compatible with the current RoHS requirements for all 6 substances, including the requirement that lead not exceed 0.1% by weight in homogeneous materials. Where designed to be soldered at high temperatures, TI Pb-Free products are suitable for use in specified lead-free processes.

Pb-Free (RoHS Exempt): This component has a RoHS exemption for either 1) lead-based flip-chip solder bumps used between the die and package, or 2) lead-based die adhesive used between the die and leadframe. The component is otherwise considered Pb-Free (RoHS compatible) as defined above.

Green (RoHS & no Sb/Br): TI defines "Green" to mean Pb-Free (RoHS compatible), and free of Bromine (Br) and Antimony (Sb) based flame retardants (Br or Sb do not exceed 0.1% by weight in homogeneous material)

(3) MSL, Peak Temp. - The Moisture Sensitivity Level rating according to the JEDEC industry standard classifications, and peak solder temperature.

(4) There may be additional marking, which relates to the logo, the lot trace code information, or the environmental category on the device.

(5) Multiple Device Markings will be inside parentheses. Only one Device Marking contained in parentheses and separated by a "-" will appear on a device. If a line is indented then it is a continuation of the previous line and the two combined represent the entire Device Marking for that device.

(6) Lead/Ball Finish - Orderable Devices may have multiple material finish options. Finish options are separated by a vertical ruled line. Lead/Ball Finish values may wrap to two lines if the finish value exceeds the maximum column width.

Important Information and Disclaimer:The information provided on this page represents TI's knowledge and belief as of the date that it is provided. TI bases its knowledge and belief on information provided by third parties, and makes no representation or warranty as to the accuracy of such information. Efforts are underway to better integrate information from third parties. TI has taken and continues to take reasonable steps to provide representative and accurate information but may not have conducted destructive testing or chemical analysis on incoming materials and chemicals. TI and TI suppliers consider certain information to be proprietary, and thus CAS numbers and other limited information may not be available for release.

In no event shall TI's liability arising out of such information exceed the total purchase price of the TI part(s) at issue in this document sold by TI to Customer on an annual basis.

OTHER QUALIFIED VERSIONS OF SN75ALS160 :

- Military: [SN55ALS160](#)

NOTE: Qualified Version Definitions:

- Military - QML certified for Military and Defense Applications

TAPE AND REEL INFORMATION



QUADRANT ASSIGNMENTS FOR PIN 1 ORIENTATION IN TAPE



*All dimensions are nominal

| Device | Package Type | Package Drawing | Pins | SPQ | Reel Diameter (mm) | Reel Width W1 (mm) | A0 (mm) | B0 (mm) | K0 (mm) | P1 (mm) | W (mm) | Pin1 Quadrant |
|-----------------|--------------|-----------------|------|------|--------------------|--------------------|---------|---------|---------|---------|--------|---------------|
| SN75ALS160DWR | SOIC | DW | 20 | 2000 | 330.0 | 24.4 | 10.8 | 13.3 | 2.7 | 12.0 | 24.0 | Q1 |
| SN75ALS160DWR | SOIC | DW | 20 | 2000 | 330.0 | 24.4 | 10.8 | 13.0 | 2.7 | 12.0 | 24.0 | Q1 |
| SN75ALS160DWRG4 | SOIC | DW | 20 | 2000 | 330.0 | 24.4 | 10.8 | 13.0 | 2.7 | 12.0 | 24.0 | Q1 |
| SN75ALS160DWRG4 | SOIC | DW | 20 | 2000 | 330.0 | 24.4 | 10.8 | 13.3 | 2.7 | 12.0 | 24.0 | Q1 |

TAPE AND REEL BOX DIMENSIONS

*All dimensions are nominal

| Device | Package Type | Package Drawing | Pins | SPQ | Length (mm) | Width (mm) | Height (mm) |
|-----------------|--------------|-----------------|------|------|-------------|------------|-------------|
| SN75ALS160DWR | SOIC | DW | 20 | 2000 | 600.0 | 144.0 | 84.0 |
| SN75ALS160DWR | SOIC | DW | 20 | 2000 | 367.0 | 367.0 | 45.0 |
| SN75ALS160DWRG4 | SOIC | DW | 20 | 2000 | 367.0 | 367.0 | 45.0 |
| SN75ALS160DWRG4 | SOIC | DW | 20 | 2000 | 367.0 | 367.0 | 45.0 |

N (R-PDIP-T**)

PLASTIC DUAL-IN-LINE PACKAGE

16 PINS SHOWN



- NOTES:
- A. All linear dimensions are in inches (millimeters).
 - B. This drawing is subject to change without notice.
 - Falls within JEDEC MS-001, except 18 and 20 pin minimum body length (Dim A).
 - The 20 pin end lead shoulder width is a vendor option, either half or full width.

DW (R-PDSO-G20)

PLASTIC SMALL OUTLINE



- NOTES:
- A. All linear dimensions are in inches (millimeters). Dimensioning and tolerancing per ASME Y14.5M-1994.
 - B. This drawing is subject to change without notice.
 - C. Body dimensions do not include mold flash or protrusion not to exceed 0.006 (0,15).
 - D. Falls within JEDEC MS-013 variation AC.

DW (R-PDSO-G20)

PLASTIC SMALL OUTLINE

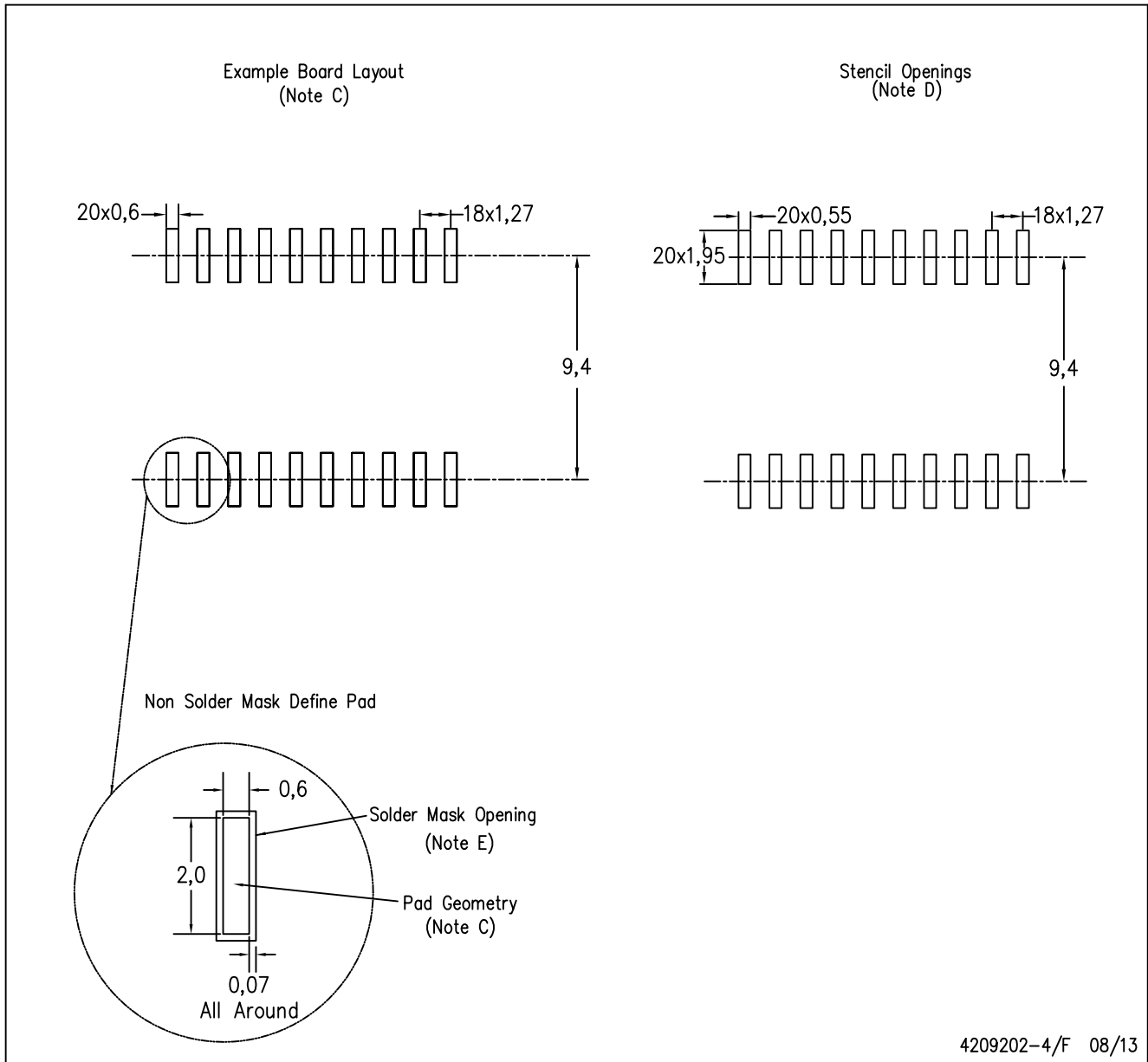

4209202-4/F 08/13

- NOTES:
- A. All linear dimensions are in millimeters.
 - B. This drawing is subject to change without notice.
 - C. Refer to IPC7351 for alternate board design.
 - D. Laser cutting apertures with trapezoidal walls and also rounding corners will offer better paste release. Customers should contact their board assembly site for stencil design recommendations. Refer to IPC-7525
 - E. Customers should contact their board fabrication site for solder mask tolerances between and around signal pads.

IMPORTANT NOTICE

Texas Instruments Incorporated and its subsidiaries (TI) reserve the right to make corrections, enhancements, improvements and other changes to its semiconductor products and services per JESD46, latest issue, and to discontinue any product or service per JESD48, latest issue. Buyers should obtain the latest relevant information before placing orders and should verify that such information is current and complete. All semiconductor products (also referred to herein as "components") are sold subject to TI's terms and conditions of sale supplied at the time of order acknowledgment.

TI warrants performance of its components to the specifications applicable at the time of sale, in accordance with the warranty in TI's terms and conditions of sale of semiconductor products. Testing and other quality control techniques are used to the extent TI deems necessary to support this warranty. Except where mandated by applicable law, testing of all parameters of each component is not necessarily performed.

TI assumes no liability for applications assistance or the design of Buyers' products. Buyers are responsible for their products and applications using TI components. To minimize the risks associated with Buyers' products and applications, Buyers should provide adequate design and operating safeguards.

TI does not warrant or represent that any license, either express or implied, is granted under any patent right, copyright, mask work right, or other intellectual property right relating to any combination, machine, or process in which TI components or services are used. Information published by TI regarding third-party products or services does not constitute a license to use such products or services or a warranty or endorsement thereof. Use of such information may require a license from a third party under the patents or other intellectual property of the third party, or a license from TI under the patents or other intellectual property of TI.

Reproduction of significant portions of TI information in TI data books or data sheets is permissible only if reproduction is without alteration and is accompanied by all associated warranties, conditions, limitations, and notices. TI is not responsible or liable for such altered documentation. Information of third parties may be subject to additional restrictions.

Resale of TI components or services with statements different from or beyond the parameters stated by TI for that component or service voids all express and any implied warranties for the associated TI component or service and is an unfair and deceptive business practice. TI is not responsible or liable for any such statements.

Buyer acknowledges and agrees that it is solely responsible for compliance with all legal, regulatory and safety-related requirements concerning its products, and any use of TI components in its applications, notwithstanding any applications-related information or support that may be provided by TI. Buyer represents and agrees that it has all the necessary expertise to create and implement safeguards which anticipate dangerous consequences of failures, monitor failures and their consequences, lessen the likelihood of failures that might cause harm and take appropriate remedial actions. Buyer will fully indemnify TI and its representatives against any damages arising out of the use of any TI components in safety-critical applications.

In some cases, TI components may be promoted specifically to facilitate safety-related applications. With such components, TI's goal is to help enable customers to design and create their own end-product solutions that meet applicable functional safety standards and requirements. Nonetheless, such components are subject to these terms.

No TI components are authorized for use in FDA Class III (or similar life-critical medical equipment) unless authorized officers of the parties have executed a special agreement specifically governing such use.

Only those TI components which TI has specifically designated as military grade or "enhanced plastic" are designed and intended for use in military/aerospace applications or environments. Buyer acknowledges and agrees that any military or aerospace use of TI components which have **not** been so designated is solely at the Buyer's risk, and that Buyer is solely responsible for compliance with all legal and regulatory requirements in connection with such use.

TI has specifically designated certain components as meeting ISO/TS16949 requirements, mainly for automotive use. In any case of use of non-designated products, TI will not be responsible for any failure to meet ISO/TS16949.

Products

| | |
|------------------------------|--|
| Audio | www.ti.com/audio |
| Amplifiers | amplifier.ti.com |
| Data Converters | dataconverter.ti.com |
| DLP® Products | www.dlp.com |
| DSP | dsp.ti.com |
| Clocks and Timers | www.ti.com/clocks |
| Interface | interface.ti.com |
| Logic | logic.ti.com |
| Power Mgmt | power.ti.com |
| Microcontrollers | microcontroller.ti.com |
| RFID | www.ti-rfid.com |
| OMAP Applications Processors | www.ti.com/omap |
| Wireless Connectivity | www.ti.com/wirelessconnectivity |

Applications

| | |
|-------------------------------|--|
| Automotive and Transportation | www.ti.com/automotive |
| Communications and Telecom | www.ti.com/communications |
| Computers and Peripherals | www.ti.com/computers |
| Consumer Electronics | www.ti.com/consumer-apps |
| Energy and Lighting | www.ti.com/energy |
| Industrial | www.ti.com/industrial |
| Medical | www.ti.com/medical |
| Security | www.ti.com/security |
| Space, Avionics and Defense | www.ti.com/space-avionics-defense |
| Video and Imaging | www.ti.com/video |

TI E2E Community

e2e.ti.com