

SINGLE-POLE DOUBLE-THROW ANALOG SWITCH

Check for Samples: [SN74LVC1G3157](#)

FEATURES

- 1.65-V to 5.5-V V_{CC} Operation
- Useful for Both Analog and Digital Applications
- Specified Break-Before-Make Switching
- Rail-to-Rail Signal Handling
- High Degree of Linearity
- High Speed, Typically 0.5 ns ($V_{CC} = 3\text{ V}$, $C_L = 50\text{ pF}$)
- Low On-State Resistance, Typically $\approx 6\ \Omega$ ($V_{CC} = 4.5\text{ V}$)
- Latch-Up Performance Exceeds 100 mA Per JESD 78, Class II
- ESD Protection Exceeds JESD 22
 - 2000-V Human-Body Model (A114-A)
 - 200-V Machine Model (A115-A)
 - 1000-V Charged-Device Model (C101)

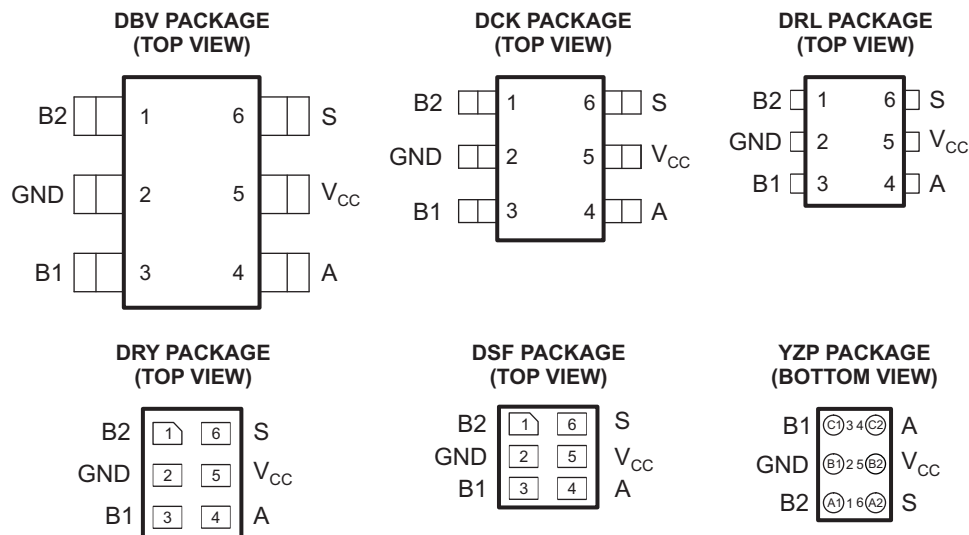

See mechanical drawings for dimensions.

DESCRIPTION/ORDERING INFORMATION

This single-pole double-throw (SPDT) analog switch is designed for 1.65-V to 5.5-V V_{CC} operation.

The SN74LVC1G3157 can handle both analog and digital signals. The device permits signals with amplitudes of up to V_{CC} (peak) to be transmitted in either direction.

Applications include signal gating, chopping, modulation or demodulation (modem), and signal multiplexing for analog-to-digital and digital-to-analog conversion systems.



Please be aware that an important notice concerning availability, standard warranty, and use in critical applications of Texas Instruments semiconductor products and disclaimers thereto appears at the end of this data sheet.

NanoFree is a trademark of Texas Instruments.

PRODUCTION DATA information is current as of publication date. Products conform to specifications per the terms of the Texas Instruments standard warranty. Production processing does not necessarily include testing of all parameters.

Copyright © 2003–2012, Texas Instruments Incorporated

ORDERING INFORMATION

T _A	PACKAGE ^{(1) (2)}		ORDERABLE PART NUMBER	TOP-SIDE MARKING ⁽³⁾
-40°C to 85°C	NanoFree™ – WCSP (DSBGA) 0.23-mm Large Bump – YZP (Pb-free)	Reel of 3000	SN74LVC1G3157YZPR	_ _ _ C5_
	SON – DRY	Reel of 5000	SN74LVC1G3157DRYR	C5
	SON – DSF	Reel of 5000	SN74LVC1G3157DSFR	C5
	SOT (SOT-23) – DBV	Reel of 3000	SN74LVC1G3157DBVR	CC5_
	SOT (SC-70) – DCK	Reel of 3000	SN74LVC1G3157DCKR	C5_
	SOT (SOT-553) – DRL	Reel of 4000	SN74LVC1G3157DRLR	C5_

- (1) Package drawings, thermal data, and symbolization are available at www.ti.com/packaging.
- (2) For the most current package and ordering information, see the Package Option Addendum at the end of this document, or see the TI website at www.ti.com.
- (3) DBV/DCK/DRL/DRY: The actual top-side marking has one additional character that designates the assembly/test site.
YZP: The actual top-side marking has three preceding characters to denote year, month, and sequence code, and one following character to designate the assembly/test site. Pin 1 identifier indicates solder-bump composition (1 = SnPb, • = Pb-free).

Table 1. FUNCTION TABLE

CONTROL INPUT S	ON CHANNEL
L	B1
H	B2

LOGIC DIAGRAM (POSITIVE LOGIC)

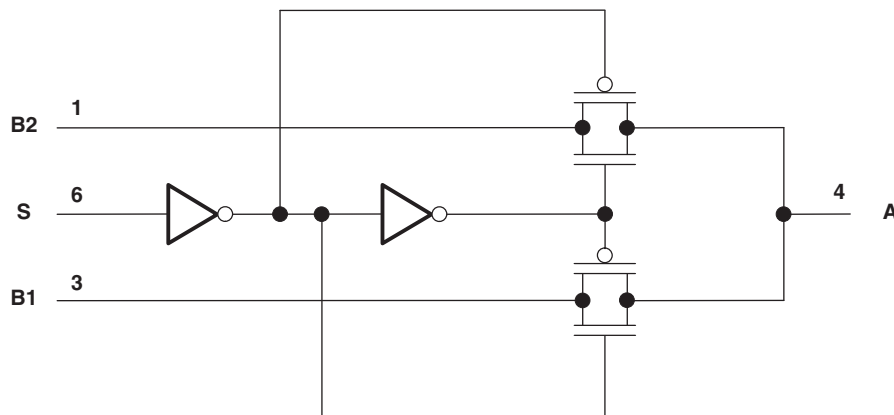

Absolute Maximum Ratings⁽¹⁾

over operating free-air temperature range (unless otherwise noted)

		MIN	MAX	UNIT
V_{CC}	Supply voltage range ⁽²⁾	-0.5	6.5	V
V_{IN}	Control input voltage range ^{(2) (3)}	-0.5	6.5	V
$V_{I/O}$	Switch I/O voltage range ^{(2) (3) (4) (5)}	-0.5	$V_{CC} + 0.5$	V
I_{IK}	Control input clamp current	$V_{IN} < 0$	-50	mA
$I_{I/O}$	I/O port diode current	$V_{I/O} < 0$ or $V_{I/O} > V_{CC}$	±50	mA
$I_{I/O}$	On-state switch current ⁽⁶⁾	$V_{I/O} = 0$ to V_{CC}	±128	mA
Continuous current through V_{CC} or GND			±100	mA
θ_{JA}	Package thermal impedance ⁽⁷⁾	DBV package	165	°C/W
		DCK package	259	
		DRL package	142	
		DRY package	234	
		YZP package	123	
T_{stg}	Storage temperature range	-65	150	°C

- (1) Stresses beyond those listed under "absolute maximum ratings" may cause permanent damage to the device. These are stress ratings only, and functional operation of the device at these or any other conditions beyond those indicated under "recommended operating conditions" is not implied. Exposure to absolute-maximum-rated conditions for extended periods may affect device reliability.
- (2) All voltages are with respect to ground unless otherwise specified.
- (3) The input and output negative-voltage ratings may be exceeded if the input and output clamp-current ratings are observed.
- (4) This value is limited to 5.5 V maximum.
- (5) V_I , V_O , V_A , and V_{Bn} are used to denote specific conditions for $V_{I/O}$.
- (6) I_I , I_O , I_A , and I_{Bn} are used to denote specific conditions for $I_{I/O}$.
- (7) The package thermal impedance is calculated in accordance with JESD 51-7.

Recommended Operating Conditions⁽¹⁾

		MIN	MAX	UNIT
V _{CC}	Supply voltage	1.65	5.5	V
V _{I/O}	Switch input/output voltage	0	V _{CC}	V
V _{IN}	Control input voltage	0	5.5	V
V _{IH}	High-level input voltage, control input	V _{CC} = 1.65 V to 1.95 V	V _{CC} × 0.75	V
		V _{CC} = 2.3 V to 5.5 V	V _{CC} × 0.7	
V _{IL}	Low-level input voltage, control input	V _{CC} = 1.65 V to 1.95 V	V _{CC} × 0.25	V
		V _{CC} = 2.3 V to 5.5 V	V _{CC} × 0.3	
Δt/Δv	Input transition rise or fall rate	V _{CC} = 1.65 V to 1.95 V	20	ns/V
		V _{CC} = 2.3 V to 2.7 V	20	
		V _{CC} = 3 V to 3.6 V	10	
		V _{CC} = 4.5 V to 5.5 V	10	
T _A	Operating free-air temperature	–40	85	°C

(1) All unused inputs of the device must be held at V_{CC} or GND to ensure proper device operation. Refer to the TI application report, *Implications of Slow or Floating CMOS Inputs*, literature number SCBA004.

Electrical Characteristics

over recommended operating free-air temperature range (unless otherwise noted)

PARAMETER	TEST CONDITIONS	V _{CC}	MIN	TYP ⁽¹⁾	MAX	UNIT
r _{on}	On-state switch resistance ⁽²⁾ See Figure 1 and Figure 2	V _I = 0 V I _O = 4 mA	1.65 V	11	20	Ω
				V _I = 1.65 V I _O = –4 mA	15	
		V _I = 0 V I _O = 8 mA	2.3 V	8	12	
				V _I = 2.3 V I _O = –8 mA	11	
		V _I = 0 V I _O = 24 mA	3 V	7	9	
				V _I = 3 V I _O = –24 mA	9	
		V _I = 0 V I _O = 30 mA	4.5 V	6	7	
				V _I = 2.4 V I _O = –30 mA	7	
		V _I = 4.5 V I _O = –30 mA	7	15		
r _{range}	On-state switch resistance over signal range ^{(2) (3)} 0 ≤ V _{Bn} ≤ V _{CC} (see Figure 1 and Figure 2)	I _A = –4 mA 1.65 V			140	Ω
I _A = –8 mA 2.3 V			45			
I _A = –24 mA 3 V			18			
I _A = –30 mA 4.5 V			10			
Δr _{on}	Difference of on-state resistance between switches ^{(2) (4) (5)} See Figure 1	V _{Bn} = 1.15 V I _A = –4 mA 1.65 V		0.5	Ω	
		V _{Bn} = 1.6 V I _A = –8 mA 2.3 V		0.1		
		V _{Bn} = 2.1 V I _A = –24 mA 3 V		0.1		
		V _{Bn} = 3.15 V I _A = –30 mA 4.5 V		0.1		
r _{on(flat)}	ON resistance flatness ^{(2) (4) (6)} 0 ≤ V _{Bn} ≤ V _{CC}	I _A = –4 mA 1.65 V		110	Ω	
		I _A = –8 mA 2.3 V		26		
		I _A = –24 mA 3 V		9		
		I _A = –30 mA 4.5 V		4		
I _{off} ⁽⁷⁾	Off-state switch leakage current 0 ≤ V _I , V _O ≤ V _{CC} (see Figure 3)	1.65 V to 5.5 V			±1 ±0.05 ±1 ⁽¹⁾	μA

(1) T_A = 25°C

(2) Measured by the voltage drop between I/O pins at the indicated current through the switch. On-state resistance is determined by the lower of the voltages on the two (A or B) ports.

(3) Specified by design

(4) Δr_{on} = r_{on(max)} – r_{on(min)} measured at identical V_{CC}, temperature, and voltage levels

(5) This parameter is characterized, but not production tested.

(6) Flatness is defined as the difference between the maximum and minimum values of on-state resistance over the specified range of conditions.

(7) I_{off} is the same as I_{S(off)} (off-state switch leakage current).

Electrical Characteristics (continued)

over recommended operating free-air temperature range (unless otherwise noted)

PARAMETER		TEST CONDITIONS	V _{CC}	MIN	TYP ⁽¹⁾	MAX	UNIT
I _{S(on)}	On-state switch leakage current	V _I = V _{CC} or GND, V _O = Open (see Figure 4)	5.5 V			±1	μA
						±0.1 ⁽¹⁾	
I _{IN}	Control input current	0 ≤ V _{IN} ≤ V _{CC}	0 V to 5.5 V			±1	μA
						±0.05 ±1 ⁽¹⁾	
I _{CC}	Supply current	S = V _{CC} or GND	5.5 V		1	10	μA
ΔI _{CC}	Supply-current change	S = V _{CC} – 0.6 V	5.5 V			500	μA
C _i	Control input capacitance	S	5 V		2.7		pF
C _{io(off)}	Switch input/output capacitance	Bn	5 V		5.2		pF
C _{io(on)}	Switch input/output capacitance	Bn	5 V		17.3		pF
		A			17.3		

Analog Switch Characteristics

 $T_A = 25^\circ\text{C}$

PARAMETER	FROM (INPUT)	TO (OUTPUT)	TEST CONDITIONS	V_{CC}	TYP	UNIT
Frequency response ⁽¹⁾ (switch on)	A or Bn	Bn or A	$R_L = 50\ \Omega$, $f_{in} =$ sine wave (see Figure 6)	1.65 V	300	MHz
				2.3 V	300	
				3 V	300	
				4.5 V	300	
Crosstalk ⁽²⁾ (between switches)	B1 or B2	B2 or B1	$R_L = 50\ \Omega$, $f_{in} = 10\ \text{MHz}$ (sine wave) (see Figure 7)	1.65 V	-54	dB
				2.3 V	-54	
				3 V	-54	
				4.5 V	-54	
Feed through attenuation ⁽²⁾ (switch off)	A or Bn	Bn or A	$C_L = 5\ \text{pF}$, $R_L = 50\ \Omega$, $f_{in} = 10\ \text{MHz}$ (sine wave) (see Figure 8)	1.65 V	-57	dB
				2.3 V	-57	
				3 V	-57	
				4.5 V	-57	
Charge injection ⁽³⁾	S	A	$C_L = 0.1\ \text{nF}$, $R_L = 1\ \text{M}\Omega$ (see Figure 9)	3.3 V	3	pC
				5 V	7	
Total harmonic distortion	A or Bn	Bn or A	$V_I = 0.5\ \text{V}_{p-p}$, $R_L = 600\ \Omega$, $f_{in} = 600\ \text{Hz}$ to $20\ \text{kHz}$ (sine wave) (see Figure 10)	1.65 V	0.1	%
				2.3 V	0.025	
				3 V	0.015	
				4.5 V	0.01	

(1) Adjust f_{in} voltage to obtain 0 dBm at output. Increase f_{in} frequency until dB meter reads -3 dB.

(2) Adjust f_{in} voltage to obtain 0 dBm at input.

(3) Specified by design

Switching Characteristics

over recommended operating free-air temperature range (unless otherwise noted) (see [Figure 5](#) and [Figure 11](#))

PARAMETER	FROM (INPUT)	TO (OUTPUT)	$V_{CC} = 1.8\ \text{V} \pm 0.15\ \text{V}$		$V_{CC} = 2.5\ \text{V} \pm 0.2\ \text{V}$		$V_{CC} = 3.3\ \text{V} \pm 0.3\ \text{V}$		$V_{CC} = 5\ \text{V} \pm 0.5\ \text{V}$		UNIT
			MIN	MAX	MIN	MAX	MIN	MAX	MIN	MAX	
t_{pd} ⁽¹⁾	A or Bn	Bn or A	2		1.2		0.8		0.3		ns
t_{en} ⁽²⁾	S	Bn	7	24	3.5	14	2.5	7.6	1.7	5.7	ns
t_{dis} ⁽³⁾			3	13	2	7.5	1.5	5.3	0.8	3.8	
t_{B-M} ⁽⁴⁾			0.5		0.5		0.5		0.5		ns

(1) t_{pd} is the slower of t_{PLH} or t_{PHL} . The propagation delay is calculated RC time constant of the typical on-state resistance of the switch and the specified load capacitance when driven by an ideal voltage source (zero output impedance).

(2) t_{en} is the slower of t_{PZL} or t_{PZH} .

(3) t_{dis} is the slower of t_{PLZ} or t_{PHZ} .

(4) Specified by design

PARAMETER MEASUREMENT INFORMATION

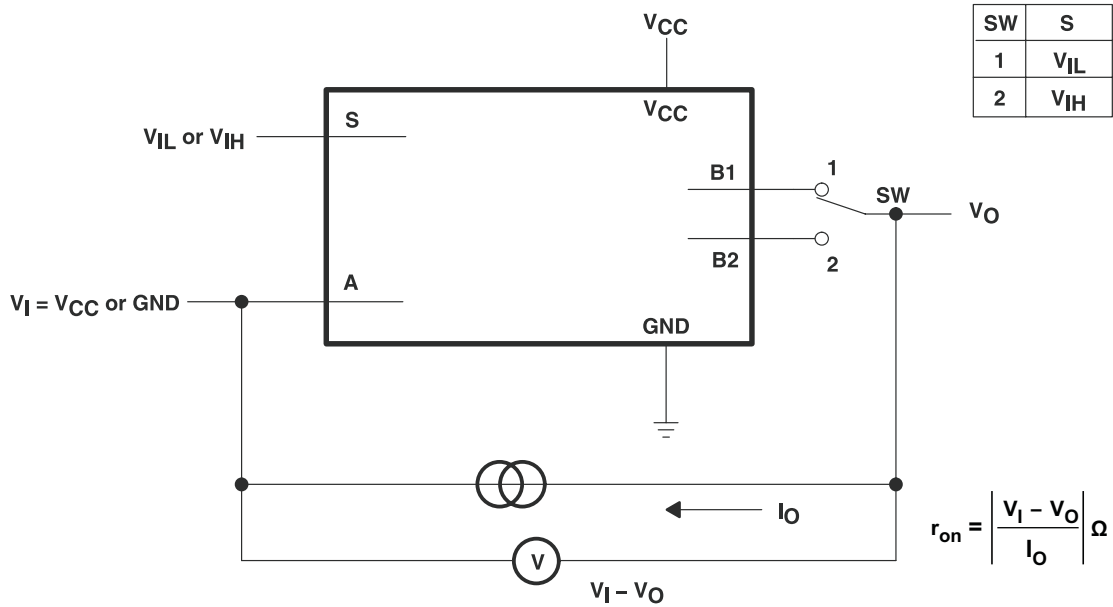

Figure 1. On-State Resistance Test Circuit

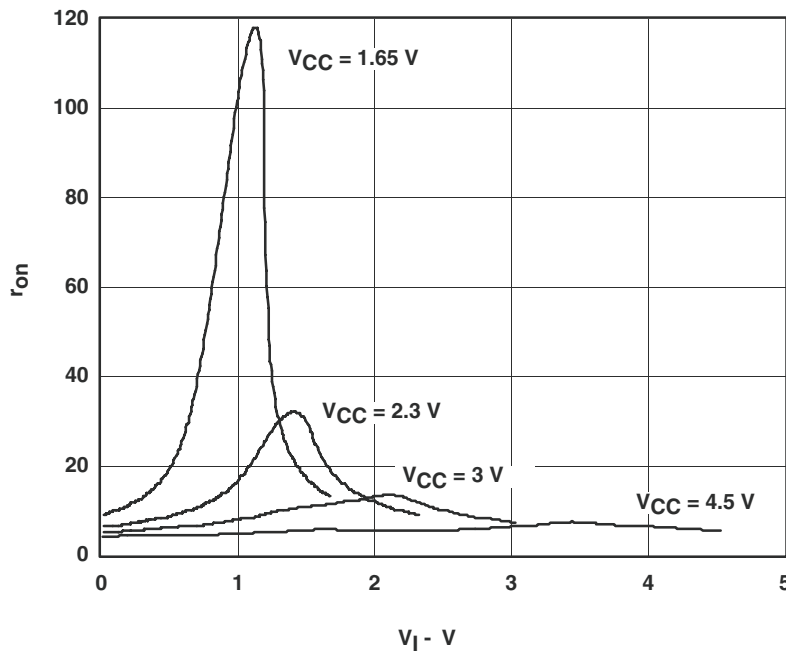
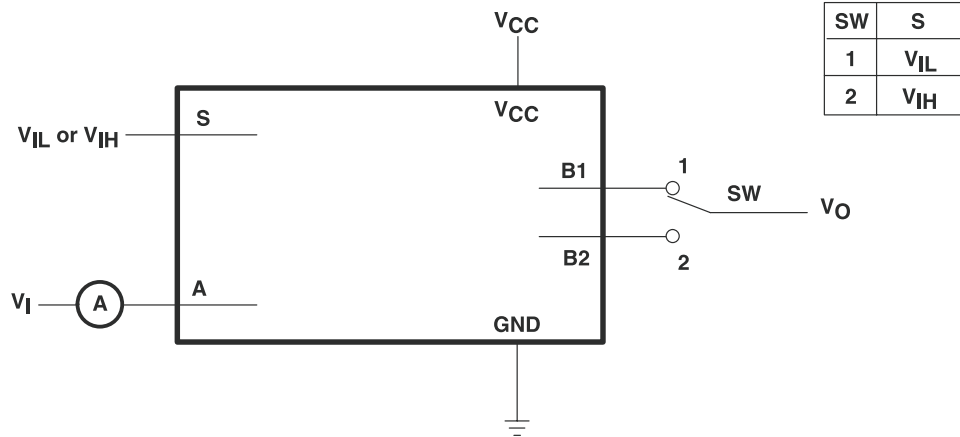

Figure 2. Typical r_{on} as a Function of Input Voltage (V_I) for $V_I = 0$ to V_{CC}

PARAMETER MEASUREMENT INFORMATION (continued)



Condition 1: $V_I = GND, V_O = V_{CC}$
 Condition 2: $V_I = V_{CC}, V_O = GND$

Figure 3. Off-State Switch Leakage-Current Test Circuit

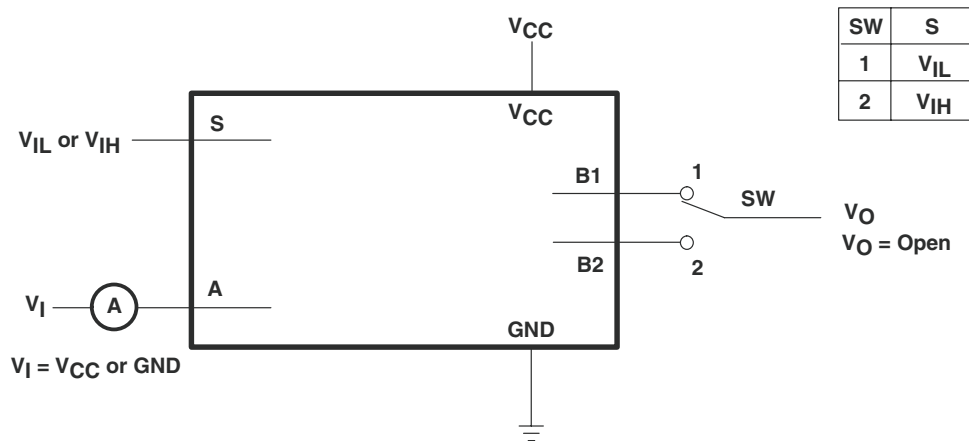
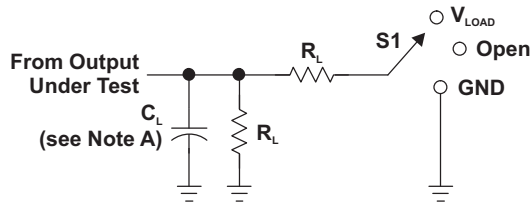

Figure 4. On-State Switch Leakage-Current Test Circuit

PARAMETER MEASUREMENT INFORMATION (continued)



LOAD CIRCUIT

TEST	S1
t_{PLH}/t_{PHL}	Open
t_{PLZ}/t_{PZL}	V_{LOAD}
t_{PHZ}/t_{PZH}	GND

V_{CC}	INPUTS		V_M	V_{LOAD}	C_L	R_L	V_{Δ}
	V_i	t_r/t_f					
$1.8\text{ V} \pm 0.15\text{ V}$	V_{CC}	$\leq 2\text{ ns}$	$V_{CC}/2$	$2 \times V_{CC}$	50 pF	500 Ω	0.3 V
$2.5\text{ V} \pm 0.2\text{ V}$	V_{CC}	$\leq 2\text{ ns}$	$V_{CC}/2$	$2 \times V_{CC}$	50 pF	500 Ω	0.3 V
$3.3\text{ V} \pm 0.3\text{ V}$	V_{CC}	$\leq 2.5\text{ ns}$	$V_{CC}/2$	$2 \times V_{CC}$	50 pF	500 Ω	0.3 V
$5\text{ V} \pm 0.5\text{ V}$	V_{CC}	$\leq 2.5\text{ ns}$	$V_{CC}/2$	$2 \times V_{CC}$	50 pF	500 Ω	0.3 V

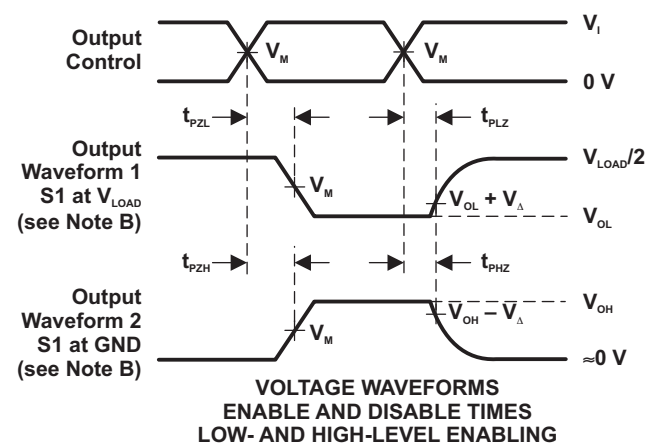
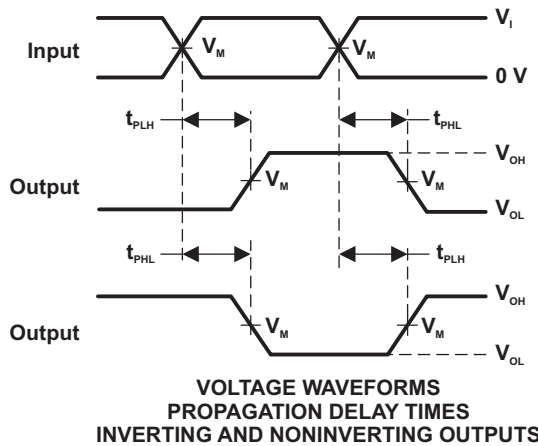
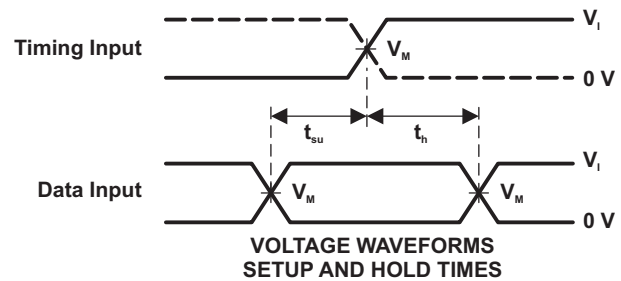
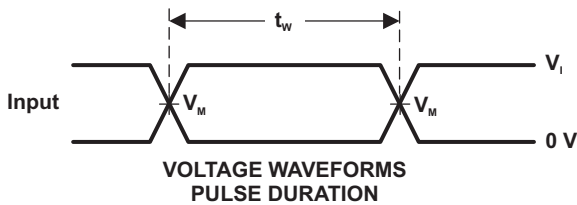

- NOTES: A. C_L includes probe and jig capacitance.
 B. Waveform 1 is for an output with internal conditions such that the output is low, except when disabled by the output control. Waveform 2 is for an output with internal conditions such that the output is high, except when disabled by the output control.
 C. All input pulses are supplied by generators having the following characteristics: PRR \leq 10 MHz, $Z_o = 50\ \Omega$.
 D. The outputs are measured one at a time, with one transition per measurement.
 E. t_{PLZ} and t_{PHZ} are the same as t_{dis} .
 F. t_{PZL} and t_{PZH} are the same as t_{en} .
 G. t_{PLH} and t_{PHL} are the same as t_{pd} .
 H. All parameters and waveforms are not applicable to all devices.

Figure 5. Load Circuit and Voltage Waveforms

PARAMETER MEASUREMENT INFORMATION (continued)

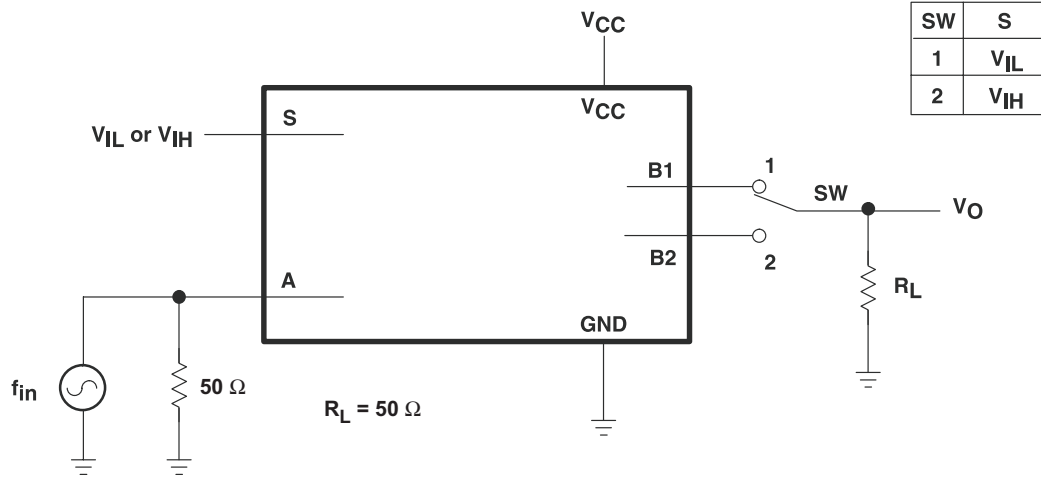

Figure 6. Frequency Response (Switch On)

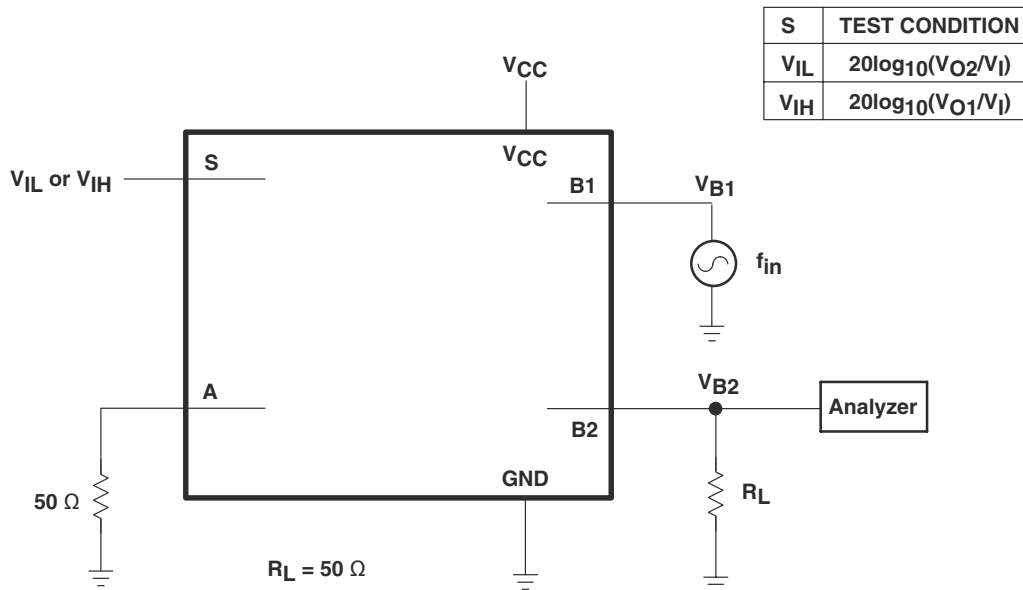

Figure 7. Crosstalk (Between Switches)

PARAMETER MEASUREMENT INFORMATION (continued)

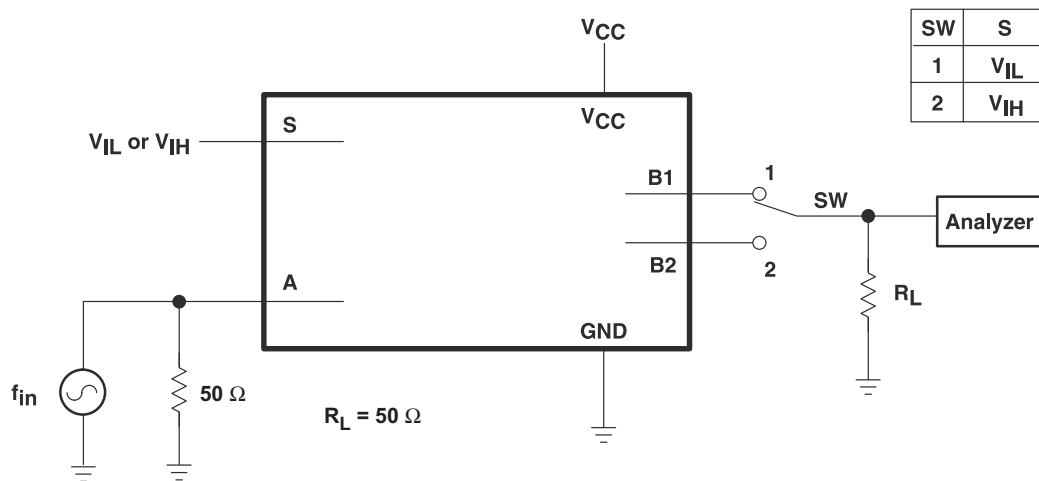

Figure 8. Feedthrough

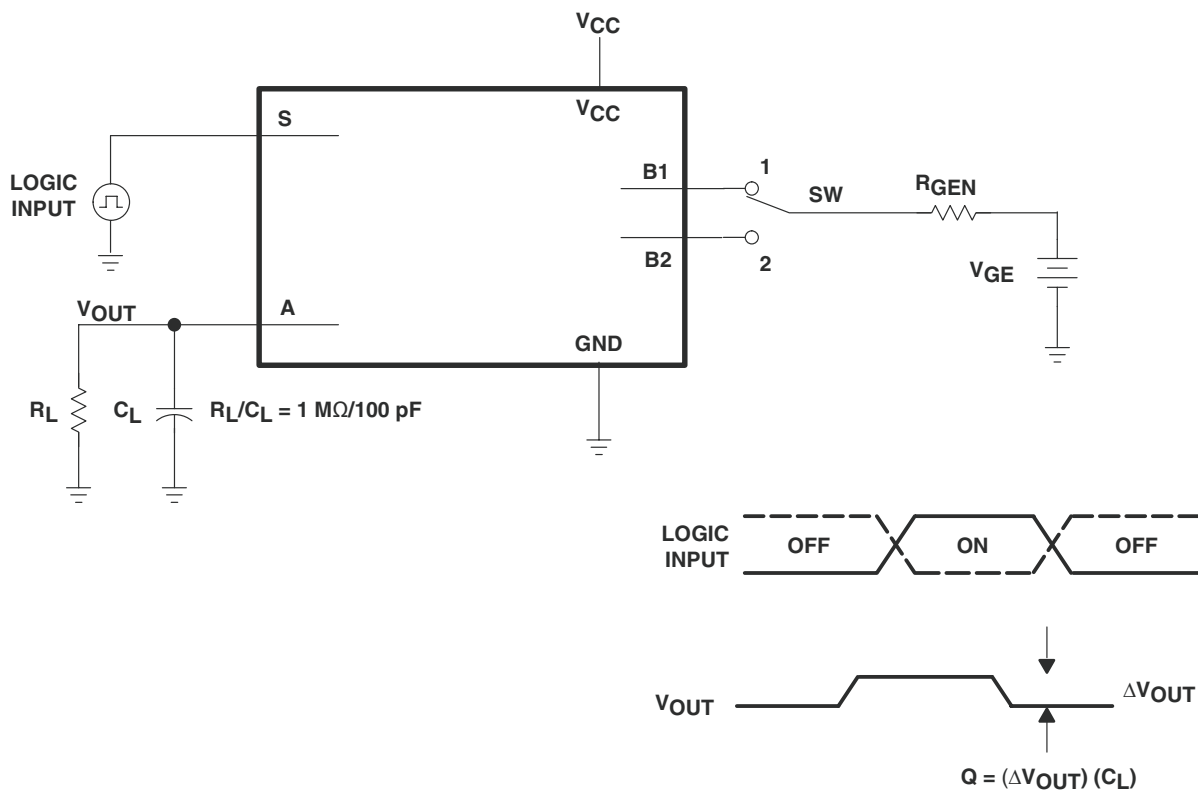

Figure 9. Charge-Injection Test

PARAMETER MEASUREMENT INFORMATION (continued)

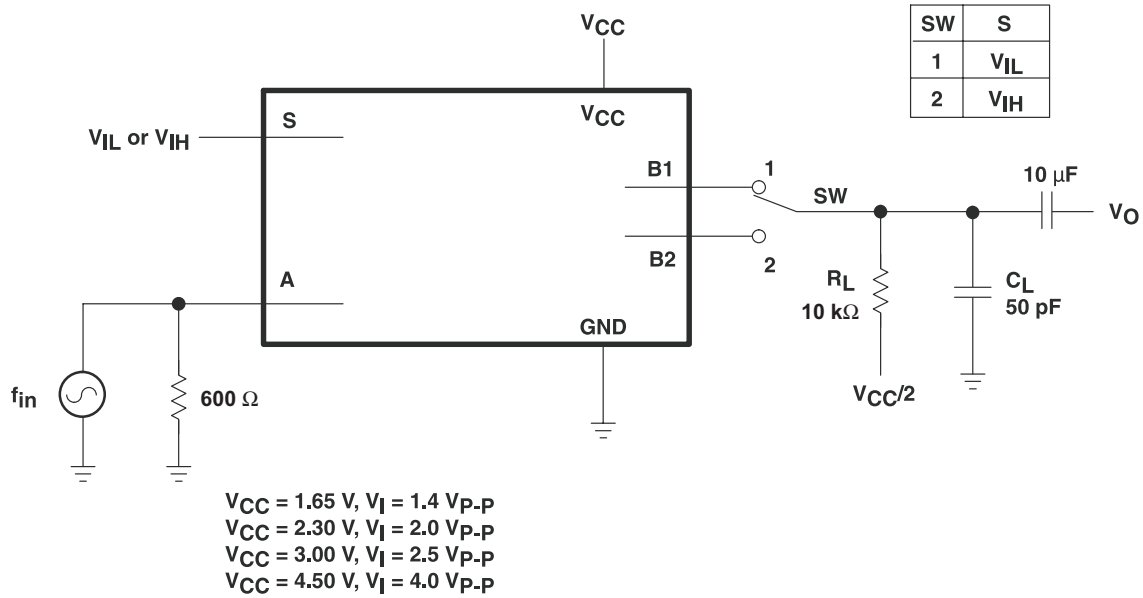

Figure 10. Total Harmonic Distortion

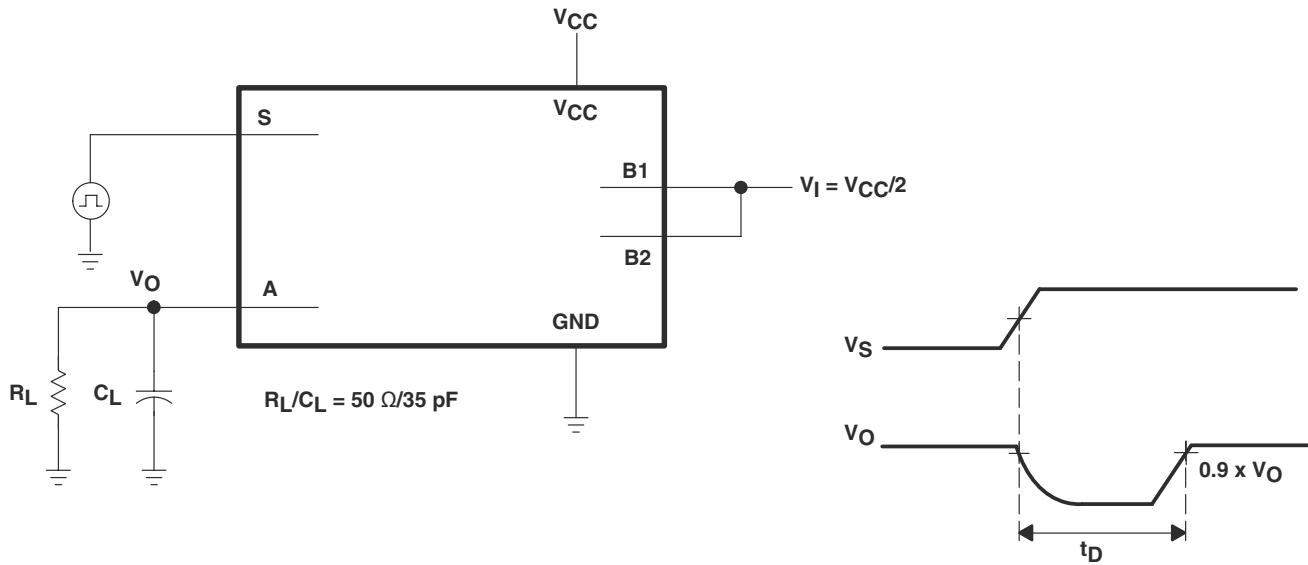

Figure 11. Break-Before-Make Internal Timing

REVISION HISTORY

Changes from Revision G (September 2011) to Revision H	Page
• Changed YZP with correct pin labels.	1
• Changed to remove _ for DRY marking	2
• Changed to correct Pin Label "S"	5

PACKAGING INFORMATION

Orderable Device	Status (1)	Package Type	Package Drawing	Pins	Package Qty	Eco Plan (2)	Lead/Ball Finish (6)	MSL Peak Temp (3)	Op Temp (°C)	Device Marking (4/5)	Samples
74LVC1G3157DBVRE4	ACTIVE	SOT-23	DBV	6	3000	Green (RoHS & no Sb/Br)	CU NIPDAU	Level-1-260C-UNLIM	-40 to 85	(CC52 ~ CC55 ~ CC5F ~ CC5K ~ CC5R)	Samples
74LVC1G3157DBVRG4	ACTIVE	SOT-23	DBV	6	3000	Green (RoHS & no Sb/Br)	CU NIPDAU	Level-1-260C-UNLIM	-40 to 85	(CC52 ~ CC55 ~ CC5F ~ CC5K ~ CC5R)	Samples
74LVC1G3157DCKRE4	ACTIVE	SC70	DCK	6	3000	Green (RoHS & no Sb/Br)	CU NIPDAU	Level-1-260C-UNLIM	-40 to 85	(C55 ~ C5F ~ C5K ~ C5R)	Samples
74LVC1G3157DCKRG4	ACTIVE	SC70	DCK	6	3000	Green (RoHS & no Sb/Br)	CU NIPDAU	Level-1-260C-UNLIM	-40 to 85	(C55 ~ C5F ~ C5K ~ C5R)	Samples
74LVC1G3157DRLRG4	ACTIVE	SOT	DRL	6	4000	Green (RoHS & no Sb/Br)	CU NIPDAU	Level-1-260C-UNLIM	-40 to 85	(C57 ~ C5R)	Samples
74LVC1G3157DRYRG4	ACTIVE	SON	DRY	6	5000	Green (RoHS & no Sb/Br)	CU NIPDAU	Level-1-260C-UNLIM	-40 to 85	C5	Samples
SN74LVC1G3157DBVR	ACTIVE	SOT-23	DBV	6	3000	Green (RoHS & no Sb/Br)	CU NIPDAU	Level-1-260C-UNLIM	-40 to 85	(CC52 ~ CC55 ~ CC5F ~ CC5K ~ CC5R)	Samples
SN74LVC1G3157DCKR	ACTIVE	SC70	DCK	6	3000	Green (RoHS & no Sb/Br)	CU NIPDAU	Level-1-260C-UNLIM	-40 to 85	(C55 ~ C5F ~ C5K ~ C5R)	Samples
SN74LVC1G3157DRLR	ACTIVE	SOT	DRL	6	4000	Green (RoHS & no Sb/Br)	CU NIPDAU	Level-1-260C-UNLIM	-40 to 85	(C57 ~ C5R)	Samples
SN74LVC1G3157DRY2	ACTIVE	SON	DRY	6	5000	Green (RoHS & no Sb/Br)	CU NIPDAU	Level-1-260C-UNLIM	-40 to 85	C5	Samples
SN74LVC1G3157DRYR	ACTIVE	SON	DRY	6	5000	Green (RoHS & no Sb/Br)	CU NIPDAU	Level-1-260C-UNLIM	-40 to 85	C5	Samples
SN74LVC1G3157DSFR	ACTIVE	SON	DSF	6	5000	Green (RoHS & no Sb/Br)	CU NIPDAU	Level-1-260C-UNLIM	-40 to 85	C5	Samples
SN74LVC1G3157YZPR	ACTIVE	DSBGA	YZP	6	3000	Green (RoHS & no Sb/Br)	SNAGCU	Level-1-260C-UNLIM	-40 to 85	(C57 ~ C5N)	Samples

(1) The marketing status values are defined as follows:

ACTIVE: Product device recommended for new designs.

LIFEBUY: TI has announced that the device will be discontinued, and a lifetime-buy period is in effect.

NRND: Not recommended for new designs. Device is in production to support existing customers, but TI does not recommend using this part in a new design.

PREVIEW: Device has been announced but is not in production. Samples may or may not be available.

OBsolete: TI has discontinued the production of the device.

(2) Eco Plan - The planned eco-friendly classification: Pb-Free (RoHS), Pb-Free (RoHS Exempt), or Green (RoHS & no Sb/Br) - please check <http://www.ti.com/productcontent> for the latest availability information and additional product content details.

TBD: The Pb-Free/Green conversion plan has not been defined.

Pb-Free (RoHS): TI's terms "Lead-Free" or "Pb-Free" mean semiconductor products that are compatible with the current RoHS requirements for all 6 substances, including the requirement that lead not exceed 0.1% by weight in homogeneous materials. Where designed to be soldered at high temperatures, TI Pb-Free products are suitable for use in specified lead-free processes.

Pb-Free (RoHS Exempt): This component has a RoHS exemption for either 1) lead-based flip-chip solder bumps used between the die and package, or 2) lead-based die adhesive used between the die and leadframe. The component is otherwise considered Pb-Free (RoHS compatible) as defined above.

Green (RoHS & no Sb/Br): TI defines "Green" to mean Pb-Free (RoHS compatible), and free of Bromine (Br) and Antimony (Sb) based flame retardants (Br or Sb do not exceed 0.1% by weight in homogeneous material)

(3) MSL, Peak Temp. - The Moisture Sensitivity Level rating according to the JEDEC industry standard classifications, and peak solder temperature.

(4) There may be additional marking, which relates to the logo, the lot trace code information, or the environmental category on the device.

(5) Multiple Device Markings will be inside parentheses. Only one Device Marking contained in parentheses and separated by a "~" will appear on a device. If a line is indented then it is a continuation of the previous line and the two combined represent the entire Device Marking for that device.

(6) Lead/Ball Finish - Orderable Devices may have multiple material finish options. Finish options are separated by a vertical ruled line. Lead/Ball Finish values may wrap to two lines if the finish value exceeds the maximum column width.

Important Information and Disclaimer: The information provided on this page represents TI's knowledge and belief as of the date that it is provided. TI bases its knowledge and belief on information provided by third parties, and makes no representation or warranty as to the accuracy of such information. Efforts are underway to better integrate information from third parties. TI has taken and continues to take reasonable steps to provide representative and accurate information but may not have conducted destructive testing or chemical analysis on incoming materials and chemicals. TI and TI suppliers consider certain information to be proprietary, and thus CAS numbers and other limited information may not be available for release.

In no event shall TI's liability arising out of such information exceed the total purchase price of the TI part(s) at issue in this document sold by TI to Customer on an annual basis.

OTHER QUALIFIED VERSIONS OF SN74LVC1G3157 :

- Automotive: [SN74LVC1G3157-Q1](#)

NOTE: Qualified Version Definitions:

- Automotive - Q100 devices qualified for high-reliability automotive applications targeting zero defects

TAPE AND REEL INFORMATION



QUADRANT ASSIGNMENTS FOR PIN 1 ORIENTATION IN TAPE



*All dimensions are nominal

Device	Package Type	Package Drawing	Pins	SPQ	Reel Diameter (mm)	Reel Width W1 (mm)	A0 (mm)	B0 (mm)	K0 (mm)	P1 (mm)	W (mm)	Pin1 Quadrant
SN74LVC1G3157DBVR	SOT-23	DBV	6	3000	178.0	9.2	3.3	3.2	1.55	4.0	8.0	Q3
SN74LVC1G3157DBVR	SOT-23	DBV	6	3000	180.0	9.2	3.17	3.23	1.37	4.0	8.0	Q3
SN74LVC1G3157DBVR	SOT-23	DBV	6	3000	178.0	9.0	3.23	3.17	1.37	4.0	8.0	Q3
SN74LVC1G3157DCKR	SC70	DCK	6	3000	178.0	9.2	2.4	2.4	1.22	4.0	8.0	Q3
SN74LVC1G3157DCKR	SC70	DCK	6	3000	180.0	9.2	2.3	2.55	1.2	4.0	8.0	Q3
SN74LVC1G3157DRLR	SOT	DRL	6	4000	180.0	8.4	1.98	1.78	0.69	4.0	8.0	Q3
SN74LVC1G3157DRLR	SOT	DRL	6	4000	180.0	9.5	1.78	1.78	0.69	4.0	8.0	Q3
SN74LVC1G3157DRY2	SON	DRY	6	5000	180.0	9.5	1.6	1.15	0.75	4.0	8.0	Q3
SN74LVC1G3157DRY2	SON	DRY	6	5000	180.0	8.4	1.65	1.2	0.7	4.0	8.0	Q3
SN74LVC1G3157DRYR	SON	DRY	6	5000	179.0	8.4	1.2	1.65	0.7	4.0	8.0	Q1
SN74LVC1G3157DSFR	SON	DSF	6	5000	180.0	9.5	1.16	1.16	0.5	4.0	8.0	Q2
SN74LVC1G3157YZPR	DSBGA	YZP	6	3000	178.0	9.2	1.02	1.52	0.63	4.0	8.0	Q1

TAPE AND REEL BOX DIMENSIONS



*All dimensions are nominal

Device	Package Type	Package Drawing	Pins	SPQ	Length (mm)	Width (mm)	Height (mm)
SN74LVC1G3157DBVR	SOT-23	DBV	6	3000	180.0	180.0	18.0
SN74LVC1G3157DBVR	SOT-23	DBV	6	3000	205.0	200.0	33.0
SN74LVC1G3157DBVR	SOT-23	DBV	6	3000	180.0	180.0	18.0
SN74LVC1G3157DCKR	SC70	DCK	6	3000	180.0	180.0	18.0
SN74LVC1G3157DCKR	SC70	DCK	6	3000	205.0	200.0	33.0
SN74LVC1G3157DRLR	SOT	DRL	6	4000	202.0	201.0	28.0
SN74LVC1G3157DRLR	SOT	DRL	6	4000	184.0	184.0	19.0
SN74LVC1G3157DRY2	SON	DRY	6	5000	184.0	184.0	19.0
SN74LVC1G3157DRY2	SON	DRY	6	5000	202.0	201.0	28.0
SN74LVC1G3157DRYR	SON	DRY	6	5000	203.0	203.0	35.0
SN74LVC1G3157DSFR	SON	DSF	6	5000	184.0	184.0	19.0
SN74LVC1G3157YZPR	DSBGA	YZP	6	3000	220.0	220.0	35.0

MECHANICAL DATA

DBV (R-PDSO-G6)

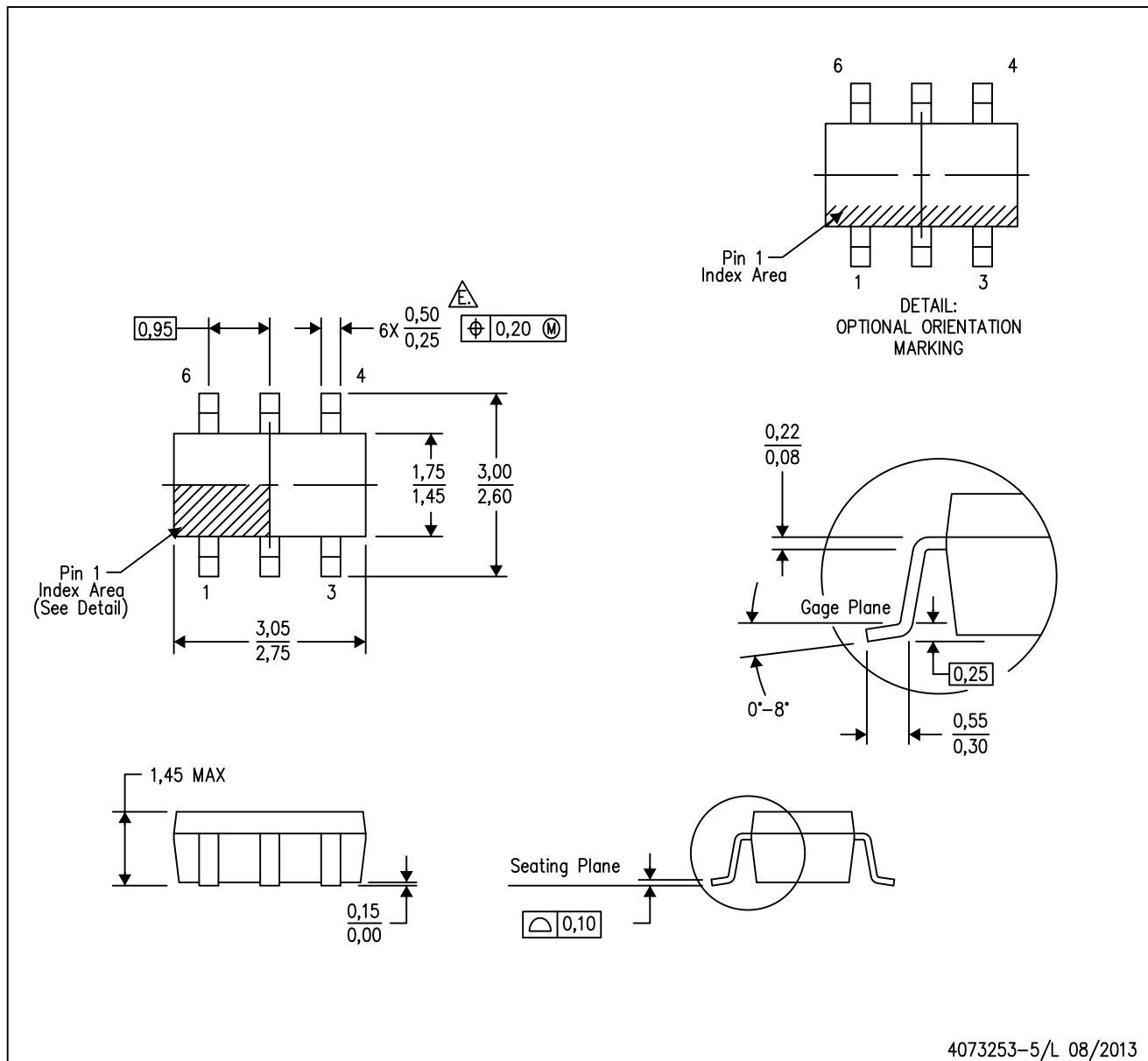
PLASTIC SMALL-OUTLINE PACKAGE



- NOTES:
- A. All linear dimensions are in millimeters.
 - B. This drawing is subject to change without notice.
 - C. Body dimensions do not include mold flash or protrusion. Mold flash and protrusion shall not exceed 0.15 per side.
 - D. Leads 1,2,3 may be wider than leads 4,5,6 for package orientation.
- ⚠ Falls within JEDEC MO-178 Variation AB, except minimum lead width.

DBV (R-PDSO-G6)

PLASTIC SMALL OUTLINE

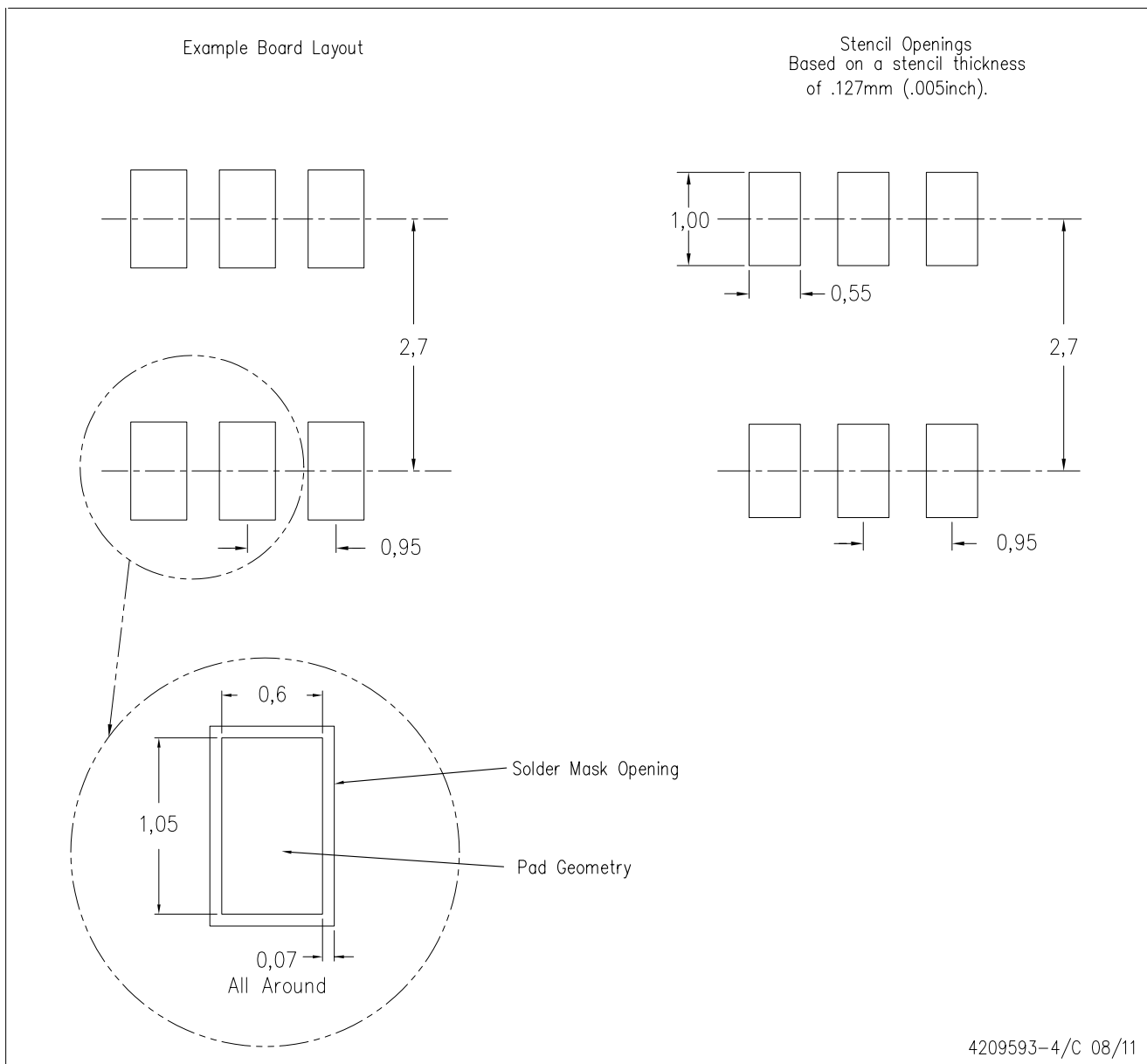

- NOTES:
- A. All linear dimensions are in millimeters.
 - B. This drawing is subject to change without notice.
 - C. Customers should place a note on the circuit board fabrication drawing not to alter the center solder mask defined pad.
 - D. Publication IPC-7351 is recommended for alternate designs.
 - E. Laser cutting apertures with trapezoidal walls and also rounding corners will offer better paste release. Customers should contact their board assembly site for stencil design recommendations. Example stencil design based on a 50% volumetric metal load solder paste. Refer to IPC-7525 for other stencil recommendations.

DCK (R-PDSO-G6)

PLASTIC SMALL-OUTLINE PACKAGE

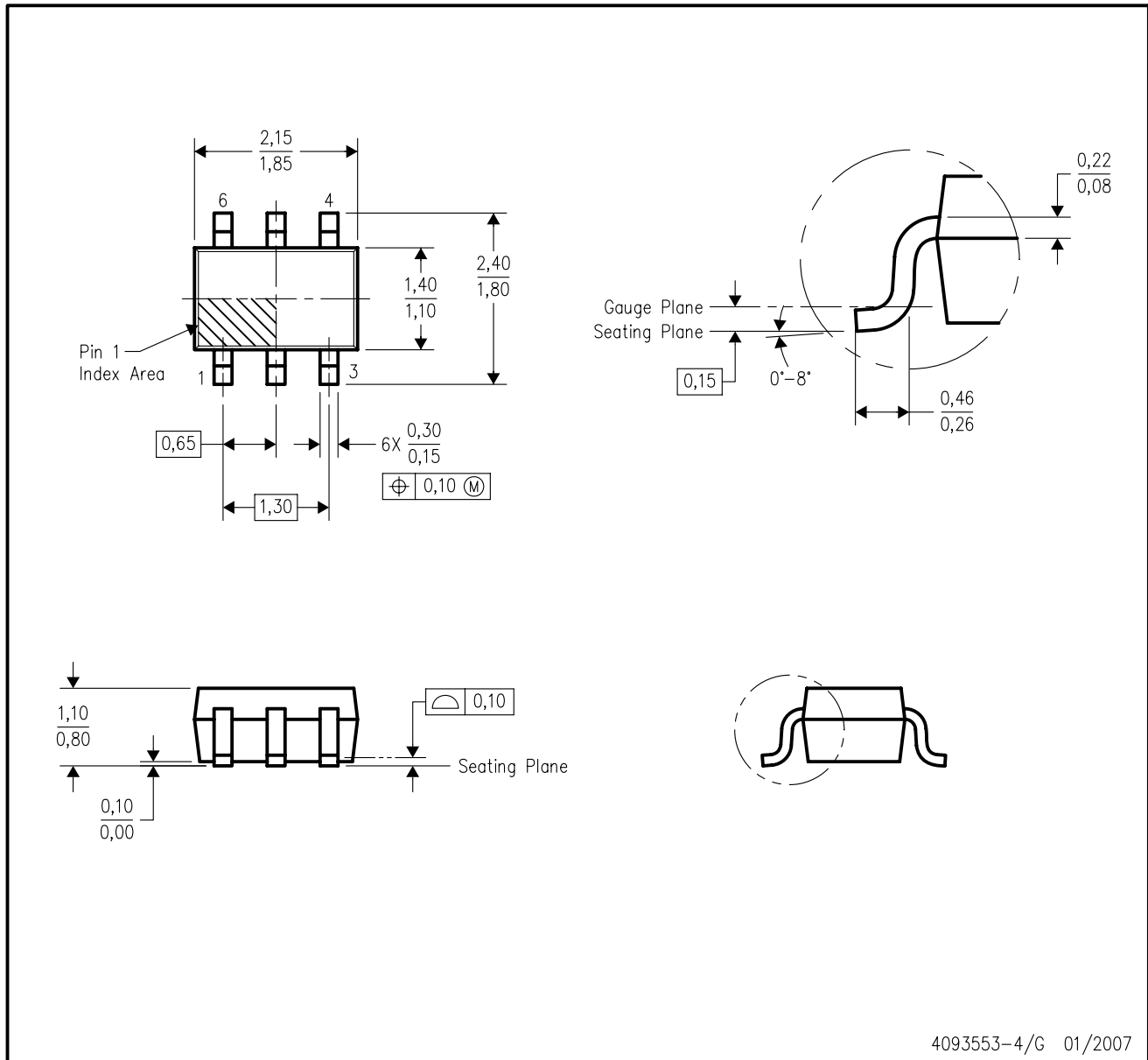

- NOTES:
- A. All linear dimensions are in millimeters.
 - B. This drawing is subject to change without notice.
 - C. Body dimensions do not include mold flash or protrusion. Mold flash and protrusion shall not exceed 0.15 per side.
 - D. Falls within JEDEC MO-203 variation AB.

DCK (R-PDSO-G6)

PLASTIC SMALL OUTLINE

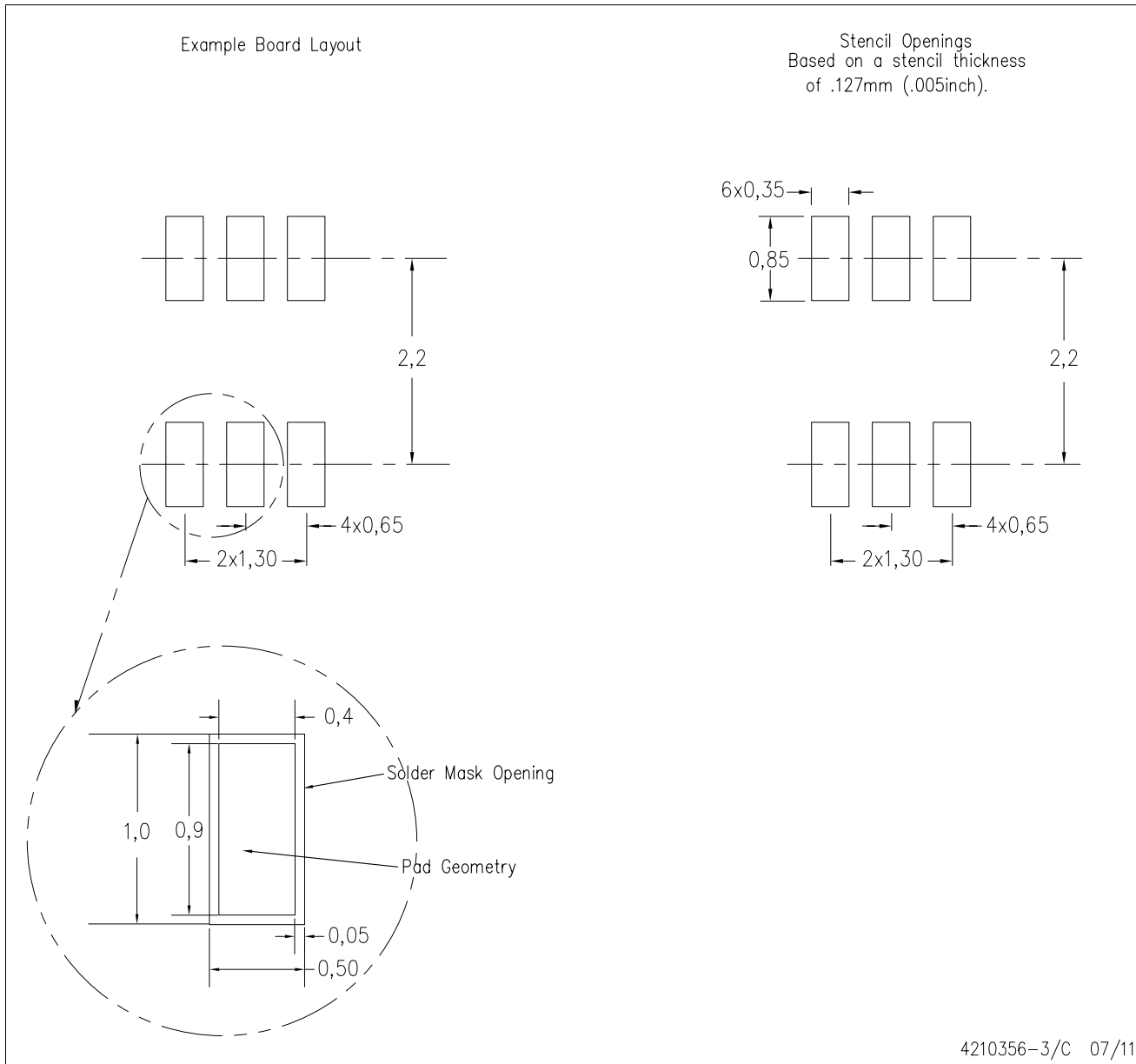

- NOTES:
- All linear dimensions are in millimeters.
 - This drawing is subject to change without notice.
 - Customers should place a note on the circuit board fabrication drawing not to alter the center solder mask defined pad.
 - Publication IPC-7351 is recommended for alternate designs.
 - Laser cutting apertures with trapezoidal walls and also rounding corners will offer better paste release. Customers should contact their board assembly site for stencil design recommendations. Example stencil design based on a 50% volumetric metal load solder paste. Refer to IPC-7525 for other stencil recommendations.

DRL (R-PDSO-N6)

PLASTIC SMALL OUTLINE

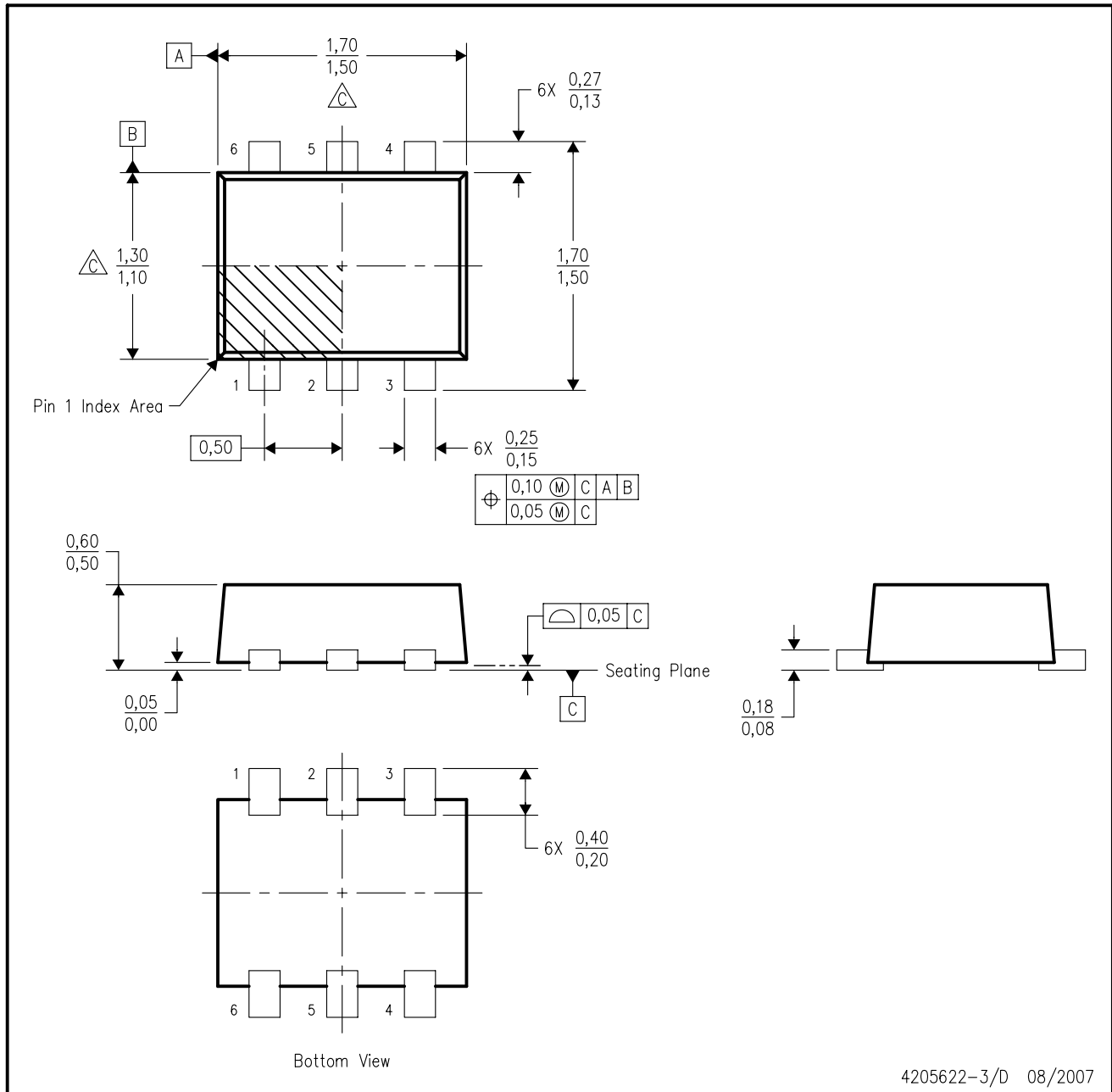

4205622-3/D 08/2007

- NOTES:
- A. All linear dimensions are in millimeters. Dimensioning and tolerancing per ASME Y14.5M-1994.
 - B. This drawing is subject to change without notice.
 - C. Body dimensions do not include mold flash, interlead flash, protrusions, or gate burrs. Mold flash, interlead flash, protrusions, or gate burrs shall not exceed 0,15 per end or side.
 - D. JEDEC package registration is pending.

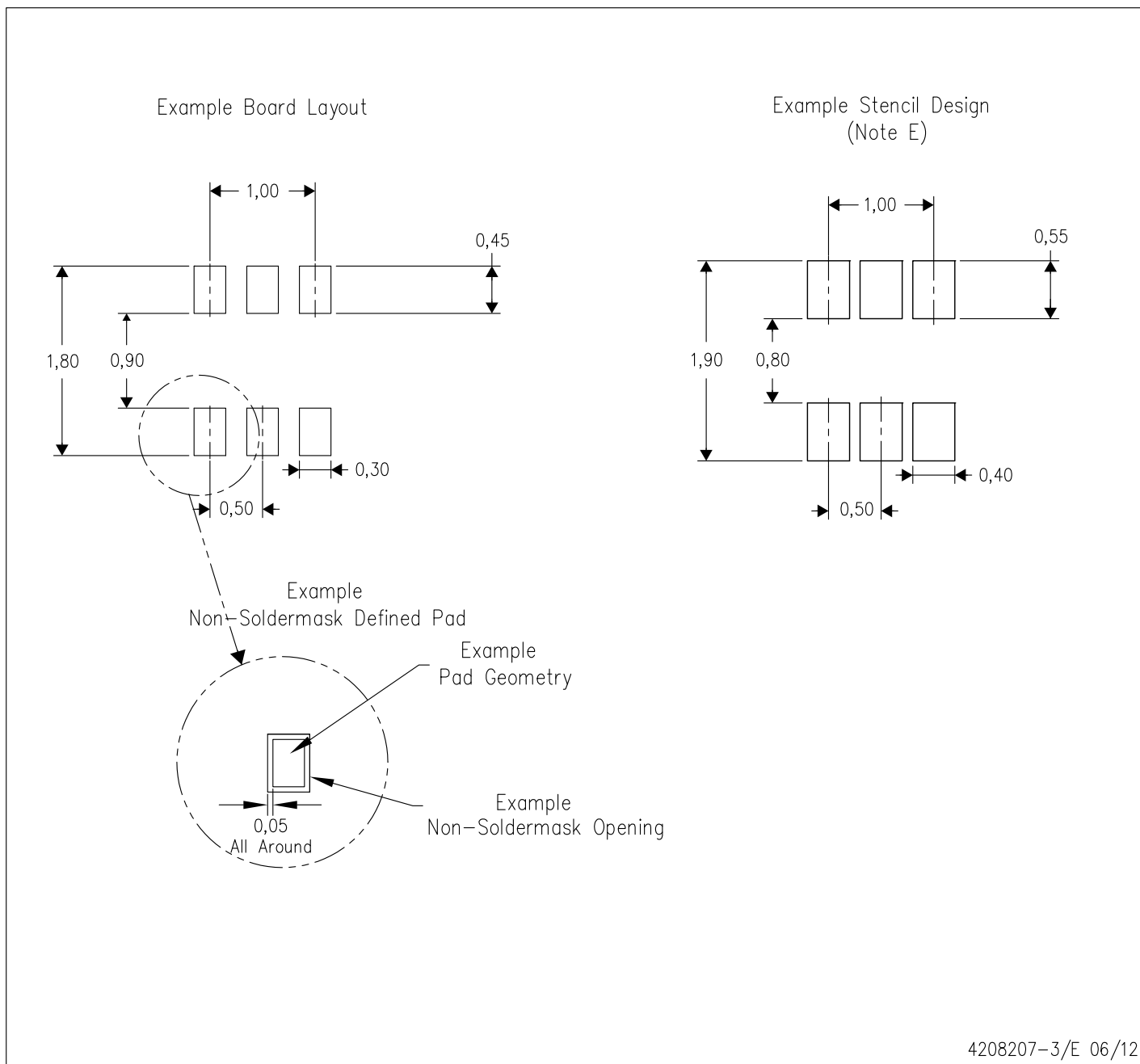

- NOTES:
- All linear dimensions are in millimeters.
 - This drawing is subject to change without notice.
 - Publication IPC-7351 is recommended for alternate designs.
 - Customers should contact their board fabrication site for minimum solder mask web tolerances between signal pads.
 - Maximum stencil thickness 0,127 mm (5 mils). All linear dimensions are in millimeters.
 - Laser cutting apertures with trapezoidal walls and also rounding corners will offer better paste release. Customers should contact their board assembly site for stencil design recommendations. Refer to IPC 7525 for stencil design considerations.
 - Side aperture dimensions over-print land for acceptable area ratio > 0.66. Customer may reduce side aperture dimensions if stencil manufacturing process allows for sufficient release at smaller opening.

DRY (R-PUSON-N6)

PLASTIC SMALL OUTLINE NO-LEAD

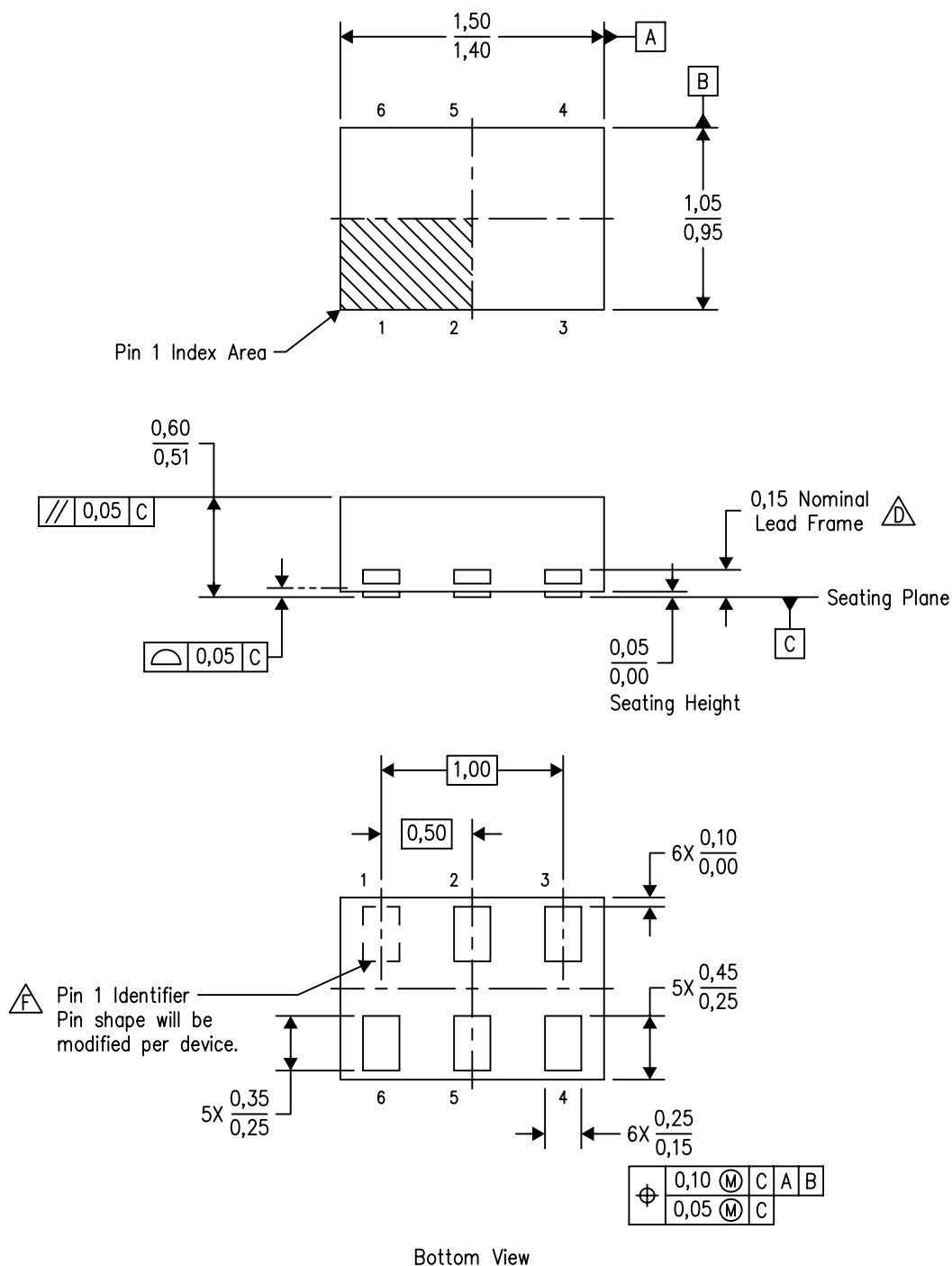

4207181/F 12/11

- NOTES:
- A. All linear dimensions are in millimeters. Dimensioning and tolerancing per ASME Y14.5M-1994.
 - B. This drawing is subject to change without notice.
 - C. SON (Small Outline No-Lead) package configuration.
 - $\triangle D$ The exposed lead frame feature on side of package may or may not be present due to alternative lead frame designs.
 - E. This package complies to JEDEC MO-287 variation UFAD.
 - $\triangle F$ See the additional figure in the Product Data Sheet for details regarding the pin 1 identifier shape.

DRY (R-PUSON-N6)

PLASTIC SMALL OUTLINE NO-LEAD

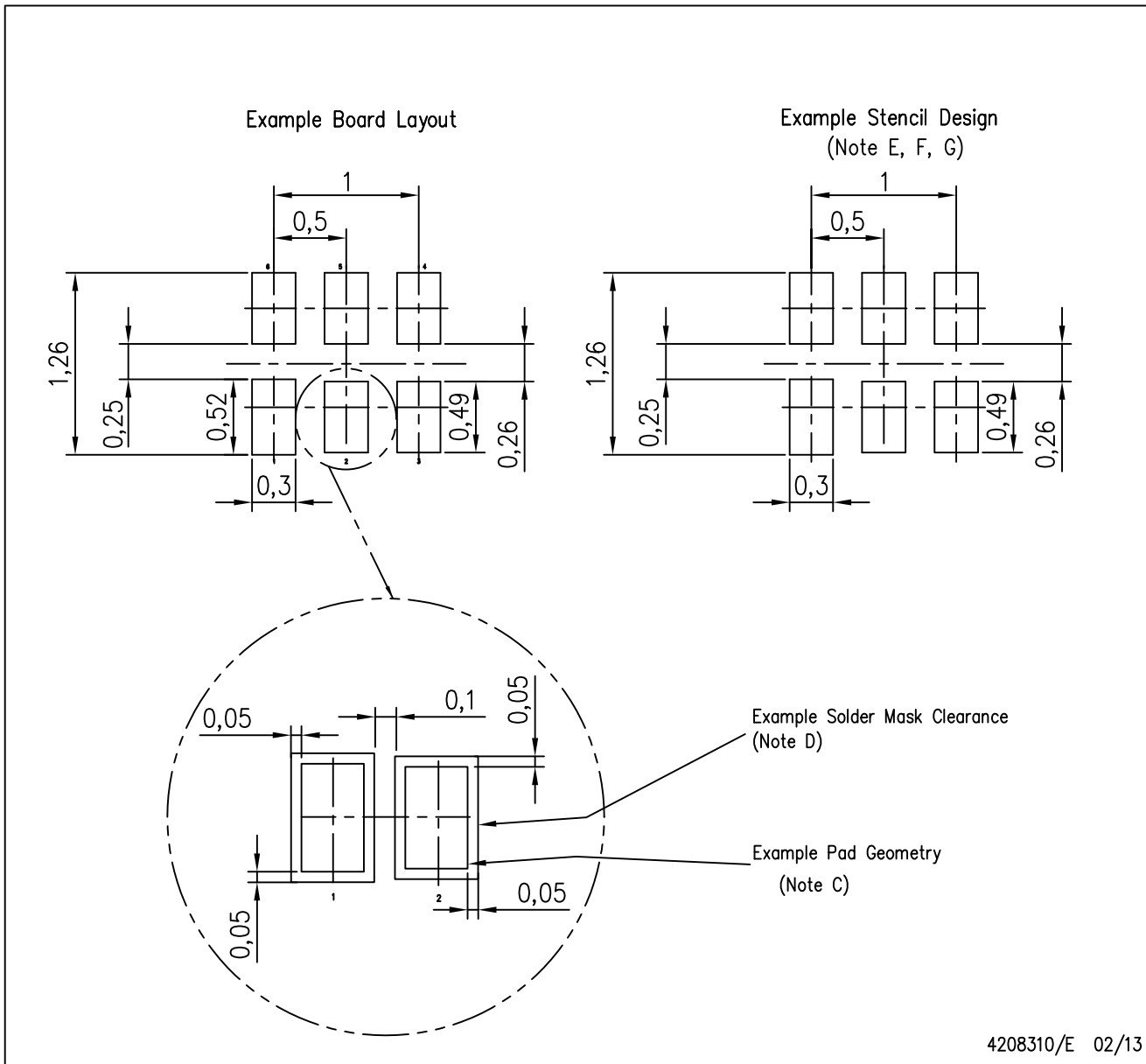

- NOTES:
- All linear dimensions are in millimeters.
 - This drawing is subject to change without notice.
 - Publication IPC-7351 is recommended for alternate designs.
 - Customers should contact their board fabrication site for minimum solder mask web tolerances between signal pads.
 - Maximum stencil thickness 0,127 mm (5 mils). All linear dimensions are in millimeters.
 - Laser cutting apertures with trapezoidal walls and also rounding corners will offer better paste release. Customers should contact their board assembly site for stencil design recommendations. Refer to IPC 7525 for stencil design considerations.
 - Side aperture dimensions over-print land for acceptable area ratio > 0.66. Customer may reduce side aperture dimensions if stencil manufacturing process allows for sufficient release at smaller opening.

DSF (S-PX2SON-N6)

PLASTIC SMALL OUTLINE NO-LEAD

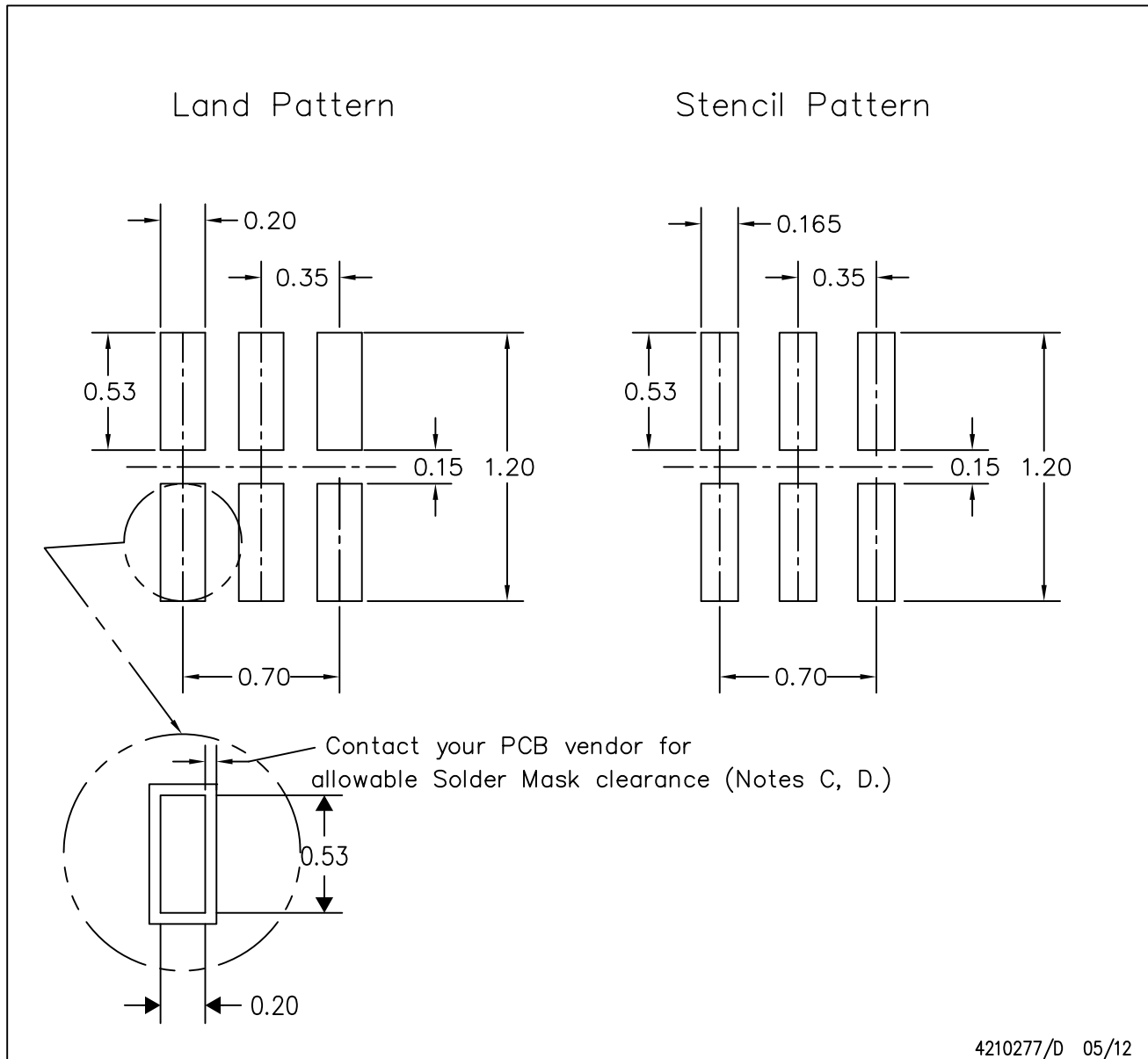

4210277/D 05/12

- NOTES:
- A. All linear dimensions are in millimeters.
 - B. This drawing is subject to change without notice.
 - C. Publication IPC-7351 is recommended for alternate designs.
 - D. Customers should contact their board fabrication site for minimum solder mask web tolerances between signal pads. If 2 mil solder mask is outside PCB vendor capability, it is advised to omit solder mask.
 - E. Maximum stencil thickness 0,1016 mm (4 mils). All linear dimensions are in millimeters.
 - F. Laser cutting apertures with trapezoidal walls and also rounding corners will offer better paste release. Customers should contact their board assembly site for stencil design recommendations. Refer to IPC 7525 for stencil design considerations.
 - G. Suggest stencils cut with lasers such as Fiber Laser that produce the greatest positional accuracy.
 - H. Component placement force should be minimized to prevent excessive paste block deformation.

YZP (R-XBGA-N6)

DIE-SIZE BALL GRID ARRAY

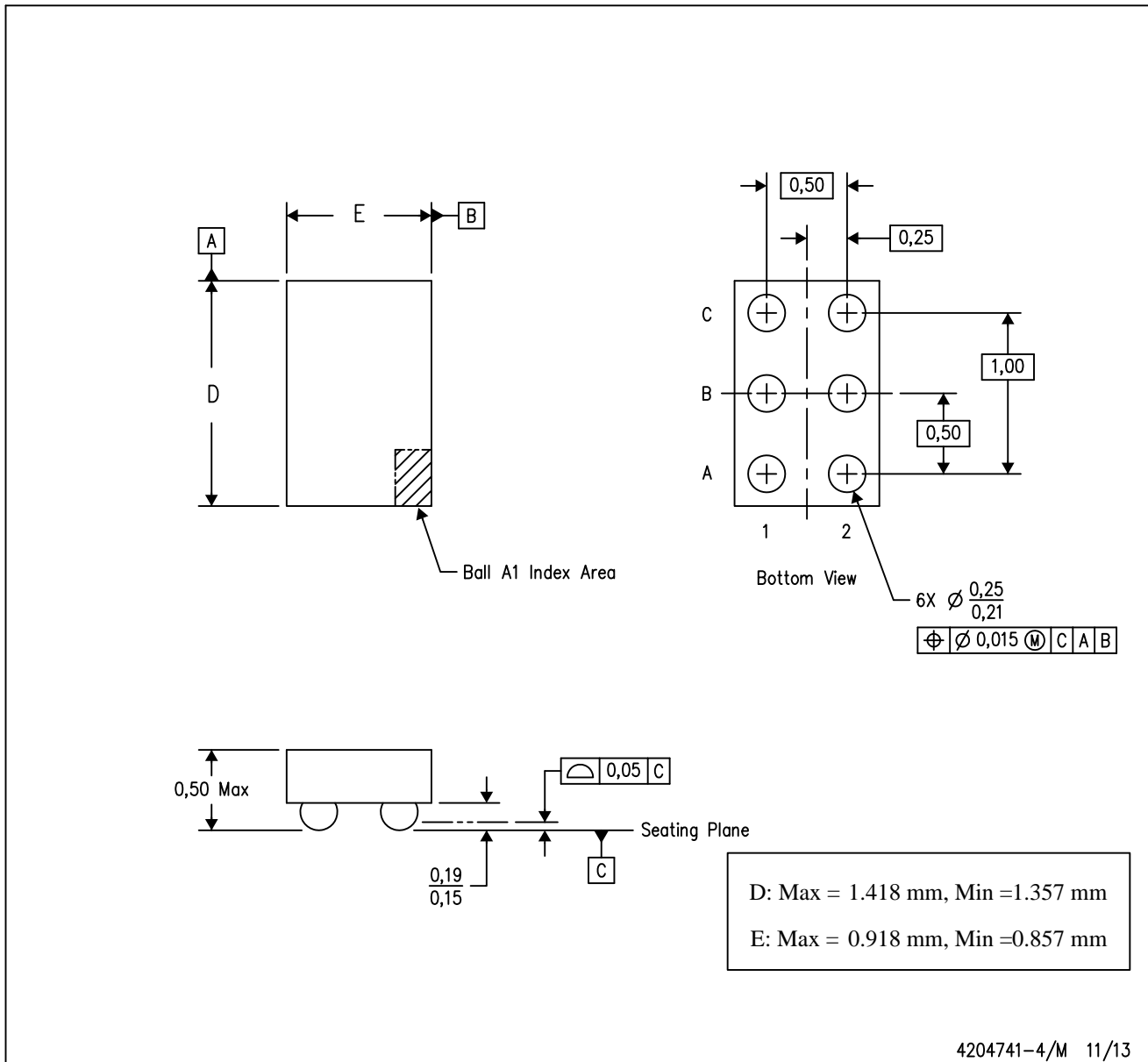

- NOTES:
- A. All linear dimensions are in millimeters. Dimensioning and tolerancing per ASME Y14.5M-1994.
 - B. This drawing is subject to change without notice.
 - C. NanoFree™ package configuration.

NanoFree is a trademark of Texas Instruments.

IMPORTANT NOTICE

Texas Instruments Incorporated and its subsidiaries (TI) reserve the right to make corrections, enhancements, improvements and other changes to its semiconductor products and services per JESD46, latest issue, and to discontinue any product or service per JESD48, latest issue. Buyers should obtain the latest relevant information before placing orders and should verify that such information is current and complete. All semiconductor products (also referred to herein as "components") are sold subject to TI's terms and conditions of sale supplied at the time of order acknowledgment.

TI warrants performance of its components to the specifications applicable at the time of sale, in accordance with the warranty in TI's terms and conditions of sale of semiconductor products. Testing and other quality control techniques are used to the extent TI deems necessary to support this warranty. Except where mandated by applicable law, testing of all parameters of each component is not necessarily performed.

TI assumes no liability for applications assistance or the design of Buyers' products. Buyers are responsible for their products and applications using TI components. To minimize the risks associated with Buyers' products and applications, Buyers should provide adequate design and operating safeguards.

TI does not warrant or represent that any license, either express or implied, is granted under any patent right, copyright, mask work right, or other intellectual property right relating to any combination, machine, or process in which TI components or services are used. Information published by TI regarding third-party products or services does not constitute a license to use such products or services or a warranty or endorsement thereof. Use of such information may require a license from a third party under the patents or other intellectual property of the third party, or a license from TI under the patents or other intellectual property of TI.

Reproduction of significant portions of TI information in TI data books or data sheets is permissible only if reproduction is without alteration and is accompanied by all associated warranties, conditions, limitations, and notices. TI is not responsible or liable for such altered documentation. Information of third parties may be subject to additional restrictions.

Resale of TI components or services with statements different from or beyond the parameters stated by TI for that component or service voids all express and any implied warranties for the associated TI component or service and is an unfair and deceptive business practice. TI is not responsible or liable for any such statements.

Buyer acknowledges and agrees that it is solely responsible for compliance with all legal, regulatory and safety-related requirements concerning its products, and any use of TI components in its applications, notwithstanding any applications-related information or support that may be provided by TI. Buyer represents and agrees that it has all the necessary expertise to create and implement safeguards which anticipate dangerous consequences of failures, monitor failures and their consequences, lessen the likelihood of failures that might cause harm and take appropriate remedial actions. Buyer will fully indemnify TI and its representatives against any damages arising out of the use of any TI components in safety-critical applications.

In some cases, TI components may be promoted specifically to facilitate safety-related applications. With such components, TI's goal is to help enable customers to design and create their own end-product solutions that meet applicable functional safety standards and requirements. Nonetheless, such components are subject to these terms.

No TI components are authorized for use in FDA Class III (or similar life-critical medical equipment) unless authorized officers of the parties have executed a special agreement specifically governing such use.

Only those TI components which TI has specifically designated as military grade or "enhanced plastic" are designed and intended for use in military/aerospace applications or environments. Buyer acknowledges and agrees that any military or aerospace use of TI components which have **not** been so designated is solely at the Buyer's risk, and that Buyer is solely responsible for compliance with all legal and regulatory requirements in connection with such use.

TI has specifically designated certain components as meeting ISO/TS16949 requirements, mainly for automotive use. In any case of use of non-designated products, TI will not be responsible for any failure to meet ISO/TS16949.

Products

Audio	www.ti.com/audio
Amplifiers	amplifier.ti.com
Data Converters	dataconverter.ti.com
DLP® Products	www.dlp.com
DSP	dsp.ti.com
Clocks and Timers	www.ti.com/clocks
Interface	interface.ti.com
Logic	logic.ti.com
Power Mgmt	power.ti.com
Microcontrollers	microcontroller.ti.com
RFID	www.ti-rfid.com
OMAP Applications Processors	www.ti.com/omap
Wireless Connectivity	www.ti.com/wirelessconnectivity

Applications

Automotive and Transportation	www.ti.com/automotive
Communications and Telecom	www.ti.com/communications
Computers and Peripherals	www.ti.com/computers
Consumer Electronics	www.ti.com/consumer-apps
Energy and Lighting	www.ti.com/energy
Industrial	www.ti.com/industrial
Medical	www.ti.com/medical
Security	www.ti.com/security
Space, Avionics and Defense	www.ti.com/space-avionics-defense
Video and Imaging	www.ti.com/video

TI E2E Community

e2e.ti.com