

MSA-0686

Cascadable Silicon Bipolar MMIC Amplifier



Data Sheet

Description

The MSA-0686 is a high performance silicon bipolar Monolithic Microwave Integrated Circuit (MMIC) housed in a low cost, surface mount plastic package. This MMIC is designed for use as a general purpose 50 Ω gain block. Typical applications include narrow and broad band IF and RF amplifiers in commercial and industrial applications.

The MSA-series is fabricated using Avago's 10 GHz f_T , 25 GHz f_{MAX} , silicon bipolar MMIC process which uses nitride self-alignment, ion implantation, and gold metalization to achieve excellent performance, uniformity and reliability. The use of an external bias resistor for temperature and current stability also allows bias flexibility.

Features

- Cascadable 50 Ω Gain Block
- Low Operating Voltage: 3.5 V Typical V_d
- 3 dB Bandwidth: DC to 0.8 GHz
- High Gain: 18.5 dB Typical at 0.5 GHz
- Low Noise Figure: 3.0 dB Typical at 0.5 GHz
- Surface Mount Plastic Package
- Tape-and-Reel Packaging Available
- Lead-free Option Available

86 Plastic Package

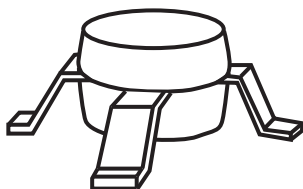

Typical Biasing Configuration

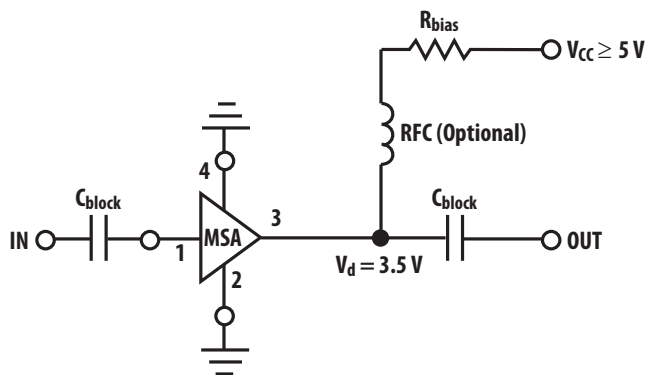

MSA-0686 Absolute Maximum Ratings

Parameter	Absolute Maximum ^[1]
Device Current	50 mA
Power Dissipation ^[2, 3]	200 mW
RF Input Power	+13 dBm
Junction Temperature	150° C
Storage Temperature	-65 to 150° C

Thermal Resistance ^{[2]:}

$$\theta_{jc} = 120^{\circ}\text{C/W}$$

Notes:

1. Permanent damage may occur if any of these limits are exceeded.
2. $T_{\text{CASE}} = 25^{\circ}\text{C}$.
3. Derate at 8.3 mW/°C for $T_C > 126^{\circ}\text{C}$.

Electrical Specifications^[1], $T_A = 25^{\circ}\text{C}$

Symbol	Parameters and Test Conditions: $I_d = 16\text{ mA}$, $Z_0 = 50\ \Omega$	Units	Min.	Typ.	Max.
G_p	Power Gain ($ S_{21} ^2$) f = 0.1 GHz f = 0.5 GHz	dB	16.5	20.0 18.5	
ΔG_p	Gain Flatness f = 0.1 to 0.5 GHz	dB		+0.7	
$f_{3\text{ dB}}$	3 dB Bandwidth ^[2]	GHz		0.8	
VSWR	Input VSWR f = 0.1 to 1.5 GHz			1.7:1	
	Output VSWR f = 0.1 to 1.5 GHz			1.7:1	
NF	50 Ω Noise Figure f = 0.5 GHz	dB		3.0	
$P_{1\text{ dB}}$	Output Power at 1 dB Gain Compression f = 0.5 GHz	dBm		2.0	
IP_3	Third Order Intercept Point f = 0.5 GHz	dBm		14.5	
t_D	Group Delay f = 0.5 GHz	psec		225	
V_d	Device Voltage	V	2.8	3.5	4.2
dV/dT	Device Voltage Temperature Coefficient	mV/°C		-8.0	

Notes:

1. The recommended operating current range for this device is 12 to 20 mA. Typical performance as a function of current is on the following page.

Ordering Information

Part Numbers	No. of Devices	Comments
MSA-0686-BLK	100	Bulk
MSA-0686-BLKG	100	Bulk
MSA-0686-TR1	1000	7" Reel
MSA-0686-TR1G	1000	7" Reel
MSA-0686-TR2	4000	13" Reel
MSA-0686-TR2G	4000	13" Reel

Note: Order part number with a "G" suffix if lead-free option is desired.

MSA-0686 Typical Scattering Parameters ($Z_0 = 50 \Omega$, $T_A = 25^\circ \text{C}$, $I_d = 16 \text{ mA}$)

Freq. GHz	S_{11}		S_{21}		S_{12}		S_{22}		k		
	Mag	Ang	dB	Mag	Ang	dB	Mag	Ang			
0.1	0.6	-175	20.1	10.08	170	-23.3	0.069	4	0.04	-84	1.05
0.2	0.6	-169	19.8	9.77	161	-23.2	0.069	8	0.07	-103	1.05
0.3	0.7	-164	19.4	9.35	152	-22.5	0.075	13	0.10	-113	1.03
0.4	0.8	-158	19.1	8.98	144	-22.2	0.078	16	0.13	-123	1.02
0.5	0.8	-154	18.7	8.58	135	-21.6	0.083	18	0.15	-131	1.01
0.6	0.9	-152	18.0	7.94	128	-21.1	0.088	21	0.18	-140	1.01
0.8	0.12	-152	17.2	7.25	114	-20.3	0.097	25	0.21	-155	1.00
1.0	0.15	-158	16.3	6.51	102	-19.5	0.106	25	0.24	-168	0.99
1.5	0.25	-171	14.0	5.01	76	-17.6	0.133	22	0.27	165	0.99
2.0	0.34	171	11.9	3.94	56	-16.1	0.157	19	0.27	147	1.01
2.5	0.43	155	9.8	3.09	42	-15.9	0.161	16	0.27	134	1.06
3.0	0.49	140	8.0	2.51	28	-15.3	0.171	11	0.26	124	1.10
3.5	0.56	128	6.4	2.09	15	-15.1	0.175	6	0.25	118	1.13
4.0	0.61	118	5.0	1.78	3	-14.9	0.180	3	0.24	115	1.15
5.0	0.70	99	2.4	1.32	-18	-14.7	0.185	-2	0.24	118	1.16

Typical Performance, $T_A = 25^\circ\text{C}$

(unless otherwise noted)

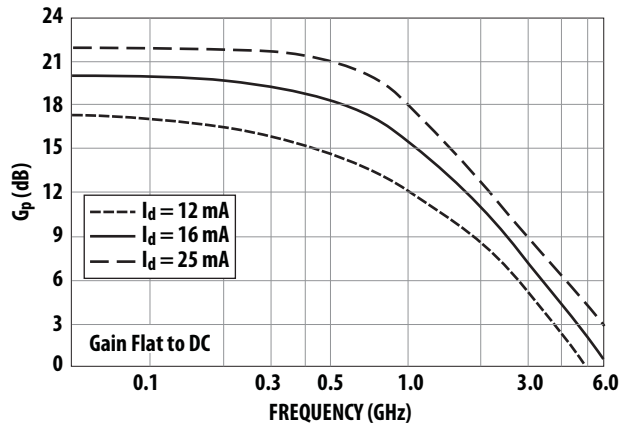

Figure 1. Typical Power Gain vs Frequency, $T_A = 25^\circ\text{C}$.

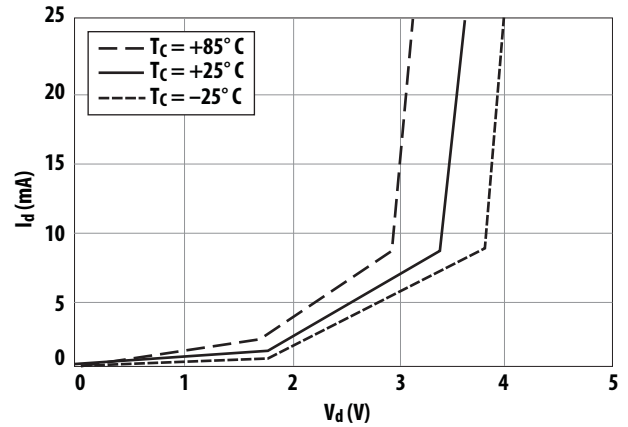

Figure 2. Device Current vs. Voltage.

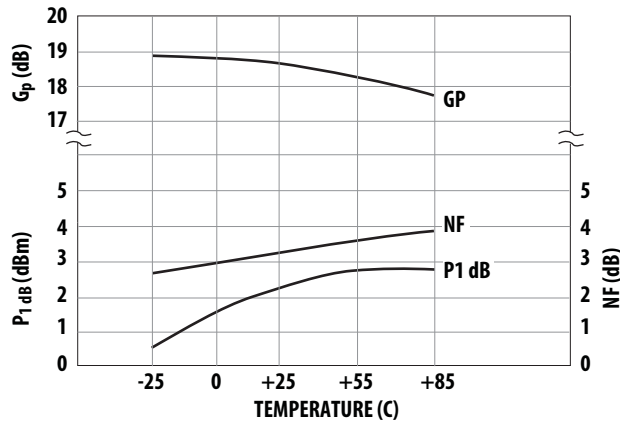

Figure 3. Output Power at 1 dB Gain Compression, NF and Power Gain vs. Case Temperature, $f = 1.0\text{ GHz}$, $I_d = 16\text{ mA}$.

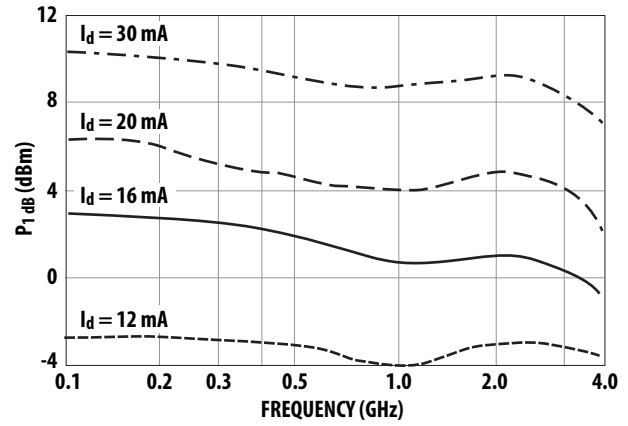

Figure 4. Output Power at 1 dB Gain Compression vs. Frequency.

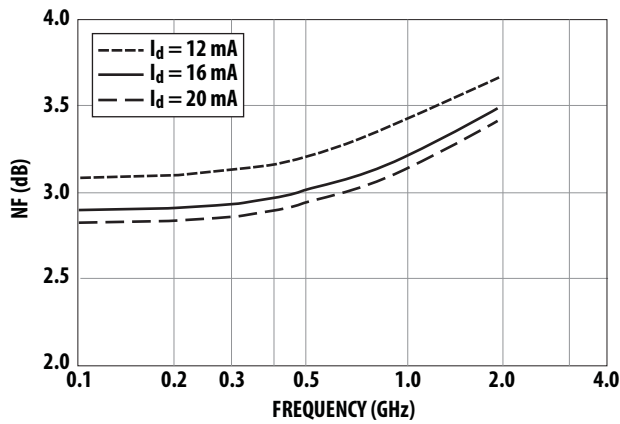
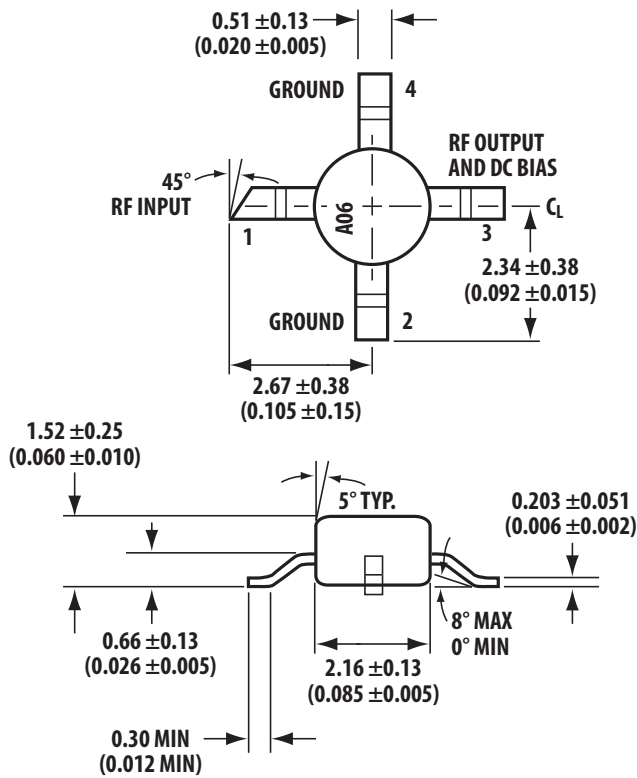

Figure 5. Noise Figure vs. Frequency.

86 Plastic Package Dimensions



Dimensions are in millimeters (inches)

For product information and a complete list of distributors, please go to our web site: www.avagotech.com

Avago, Avago Technologies, and the A logo are trademarks of Avago Technologies in the United States and other countries. Data subject to change. Copyright © 2005-2012 Avago Technologies. All rights reserved. Obsoletes 5989-2757EN AV02-3583EN - June 11, 2012

AVAGO
TECHNOLOGIES