

L-573XX 5.0 mm Dia CYLINDRICAL LED LAMP

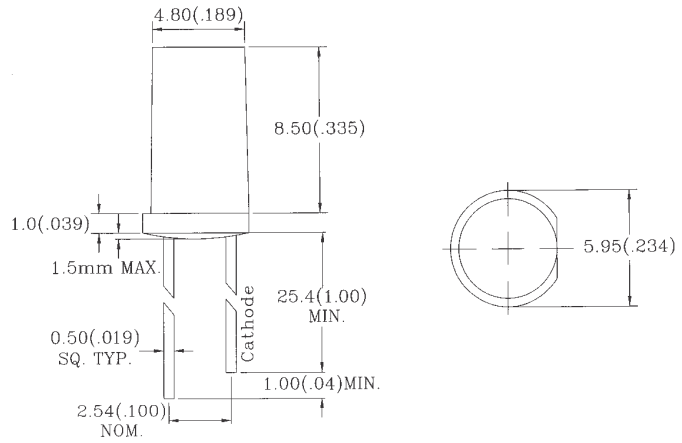

Part No.	Chip		Lens Color	Wave Length λ p(nm)	Electro-Optical Characteristics			View Angle (deg)
	Raw Material	Emitted Color			Vf(V)20mA		lv(mcd)20mA	
					Typ.	Max.	Typ.	
L-573HD	GaP	Red	Red Diffused	700	2.3	2.8	2.0	150
L-573GD	GaP	Green	Green Diffused	565	2.2	2.8	5.0	150
L-573YD	GaAsP/GaP	Yellow	Yellow Diffused	585	2.1	2.8	4.0	150
L-573ED	GaAsP/GaP	Hi.effi Red	Red Diffused	635	2.1	2.8	8.0	150
L-573SRD	GaAlAs	Super Red	Red Diffused	660	1.8	2.2	12.0	150

L-593XX 5.0 mm Dia LOW PROFILE LED LAMP

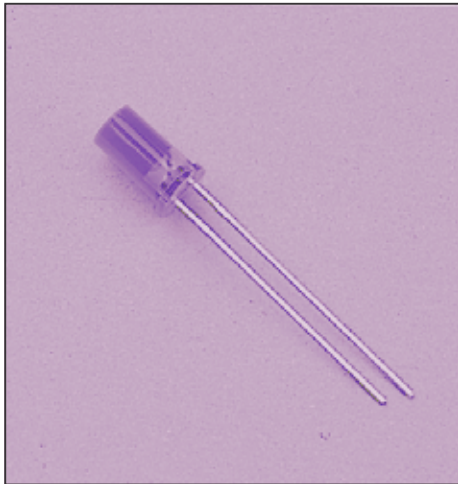
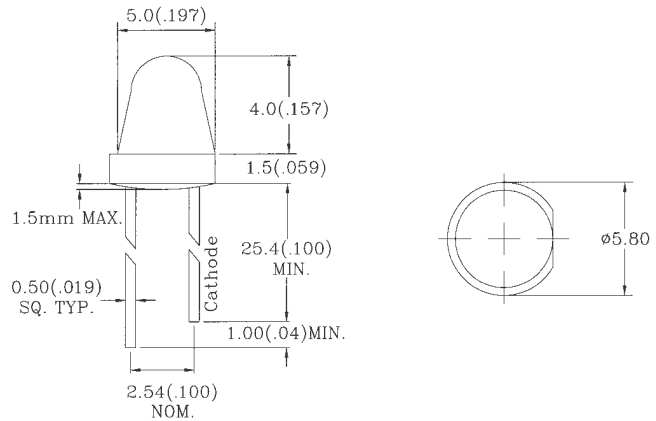
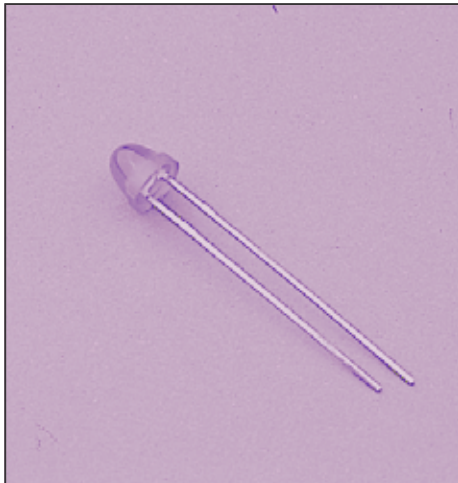

Part No.	Chip		Lens Color	Wave Length λ p(nm)	Electro-Optical Characteristics			View Angle (deg)
	Raw Material	Emitted Color			Vf(V)20mA		lv(mcd)20mA	
					Typ.	Max.	Typ.	
L-593HD	GaP	Red	Red Diffused	700	2.3	2.8	3.0	100
L-593GD	GaP	Green	Green Diffused	565	2.1	2.8	8.0	100
L-593YD	GaAsP/GaP	Yellow	Yellow Diffused	585	2.1	2.8	7.0	100
L-593ED	GaAsP/GaP	Hi.effi Red	Red Diffused	635	2.1	2.8	14.0	100
L-593SRD	GaAlAs	Super Red	Red Diffused	660	1.8	2.2	20.0	100

- 1.All dimension are in millimeters (inches).
- 2.Tolerance is ± 0.25 mm (0.01") unless otherwise specified.