

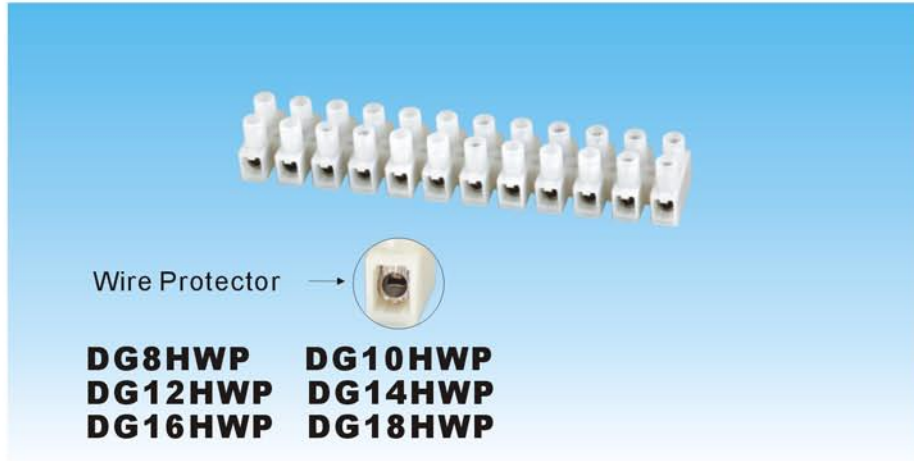

DEGSON ELECTRONICS CO., LTD.

Product Specification



Model	mm ²	Amp	Volt.	Screw	Dimensions (mm/in.)						
					Unit	A	B	C	D	E	F
DG8HWP-1.2	1.5	17.5A	450V	M2.6X5	(mm)	93.5	17.8	15.50	8.00	3.00	2.80
DG10HWP-1.2	2.5	24A	450V	M3.0X6	(mm)	116.5	20.0	16.70	10.00	3.50	3.30
DG12HWP-1.2	6.0	41A	750V	M3.5X7	(mm)	140.7	23.80	19.00	12.00	3.90	3.90
DG14HWP-1.2	10.0	57A	750V	M4X9	(mm)	158.0	25.60	25.20	13.50	4.40	4.80
DG16HWP-1.2	16.0	76A	750V	M4X9	(mm)	169.8	28.80	23.00	14.50	4.20	6.00
DG18HWP-1.2	25.0	101A	750V	M5X11	(mm)	194.4	36.90	28.70	16.50	4.20	7.50

Model: DG□HWP-1.2

Base: With 1.2mm elevated base
Housing material: PA66, UL94V-2
Working temperature: 110°C
Poles available: 2-12 poles

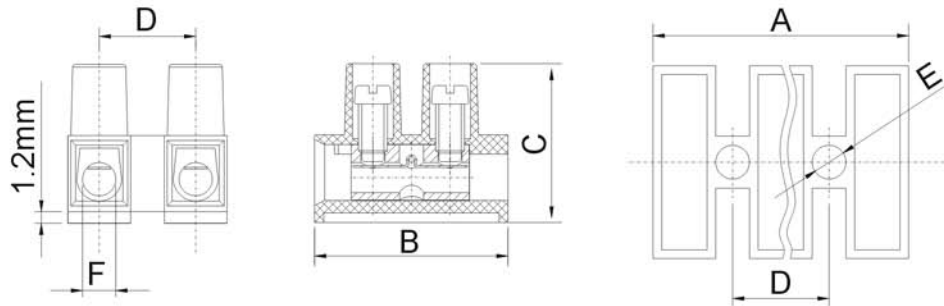

HOW TO ORDER:

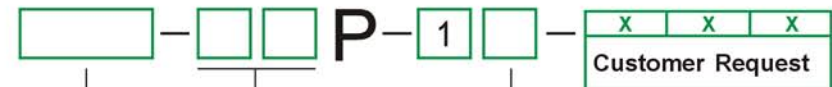

Series No. No of Pole

Color

1 Gray	4 Green	7 Trans-parent
2 Blue	5 Orange	8 Yellow
3 Black	6 Red	9 White

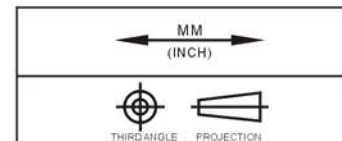

DEGSON ELECTRONICS CO., LTD.

NAME

DG8HWP-1.2 DG10HWP-1.2
DG12HWP-1.2 DG14HWP-1.2
DG16HWP-1.2 DG18HWP-1.2