

Rittal – The System.

Faster – better – everywhere.

Socket-System Flex-Block 100 mm
Flex-Block base/plinth system 100 mm
Socles Flex-Block 100 mm



Montage- und Bedienungsanleitung
Assembly and operating instructions
Notice d'emploi et de montage

ENCLOSURES

POWER DISTRIBUTION

CLIMATE CONTROL

IT INFRASTRUCTURE

SOFTWARE & SERVICES

FRIEDHELM LOH GROUP





Inhaltsverzeichnis/Contents/Sommaire



i

2-4,
13-14



5



6

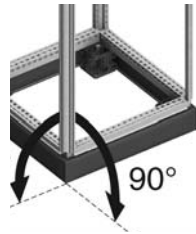

7

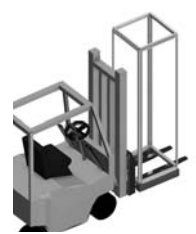

12



Zubehör/Accessories/Accessoires



8

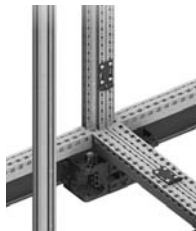

9

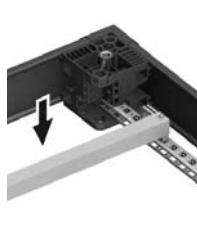

9



10



10















11





Lieferumfang/Scope of supply/Composition de la livraison

Flex-Block Eckstücke Flex-Block Corner pieces Flex-Block Pièces d'angle

Best.-Nr. Model No. Référence		8X00.000	
			
 F [N]		↓ 15000	↓ 3750
		4 x	
		4 x	
		4 x	
	4,2 x 13	16 x	
	M12 x 40	4 x	
	4,2 MKB	16 x	
	Ø 12	8 x	
	M12	4 x	

Flex-Block Blenden, geschlossen Flex-Block Trim panels, unvented Flex-Block Plaques de socle, sans aération

Best.-Nr. Model No. Référence		8X00.XXX
		2 x
		

Flex-Block Blenden, belüftet Flex-Block Trim panels, vented Flex-Block Plaques de socle ajouré

Best.-Nr. Model No. Référence		8100.X02
		2 x
		



Technische Informationen Technical information Informations techniques

D

Brandklasse: UL 94 - HB
Brandlast: 40 MJ (bei 100 mm Sockel)
Temperaturbeständigkeit: -40°C - +80°C
IK Code: IK 10 (geschlossen)

EN

Fire classification: UL 94 - HB
Fire load: 40 MJ (for 100 mm base/plinth)
Temperature resistance: -40°C - +80°C
IK code: IK 10 (closed)

F

Classe de feu : UL 94 - HB
Charge calorifique : 40 MJ
(pour un socle de 100 mm)
Constance thermique : -40°C - +80°C
Code IK : IK 10 (fermé)



Hinweise/Notes/Consignes

D

Hinweise zur Dokumentation

Die Montageanleitung richtet sich an alle Personen, die über eine entsprechende Fachausbildung verfügen, um Sockel normgerecht mit elektrischen, elektronischen, mechanischen oder pneumatischen Betriebsmitteln auszurüsten, am Bestimmungsort aufzustellen bzw. zu montieren und betriebsfertig anzuschließen.

Mitgeltende Unterlagen

Für die hier beschriebenen Ausrüstungsgegenstände existiert die Montageanleitung als Papierdokument dem Artikel beiliegend. Für Schäden, die durch Nichtbeachtung dieser Anleitung entstehen, übernehmen wir keine Haftung. Zusätzlich gelten auch die Anleitungen des verwendeten Zubehörs.

Sicherheitshinweise



Gefahr!
Unmittelbare Gefahr für Leib und Leben.

Der Sockel ist für folgende Produktserien geeignet:

- TS
- SE
- PC

Montage und Aufstellung

- Um ein evtl. Kippen des Sockels im verbauten Zustand mit Aufbauten (z. B. Schrank-/Pult-/Standssystemen, Bedingehäusen) zu verhindern, muss dieser unbedingt am Boden verschraubt werden. Ein zusätzliches Fixieren der Aufbauten an einer Wand kann mittels Wandhalter erfolgen.
- Schrank-/Pult-/Standssysteme, Bedingehäuse mit montiertem Sockel müssen stets, insbesondere auch während Transport, Auf- und Ausbau sowie Bearbeitung, durch geeignete Maßnahmen gegen Kippen gesichert werden. Hier existieren bei sämtlichen Schranksystemen entsprechende Hinweise in den Anleitungen.
Beim Transport einschließlich dem Anheben und dem Absetzen ist darauf zu achten, dass die Last immer auf den Sockel-Eckstücken lastet und niemals auf den Sockelblenden.

Vor der Montage ist zu beachten, dass:

- die Umgebungstemperatur am Aufstellort nicht höher als +80°C ist
- die Umgebungstemperatur am Aufstellort nicht niedriger als -40°C ist
- der Sockel nach dem Aufstellen waagrecht steht. Eventuelle Unebenheiten am Aufstellort können mittels Nivellierfüßen ausgeglichen werden.

Hinweise zur Montage

- Halten Sie die auf Seite 12 vorgegebenen Belastungsangaben ein.
- Halten Sie alle vorgegebenen Drehmomentangaben ein. Ein Über- bzw. Unterschreiten der in dieser Anleitung vorgegebenen Anzugsdrehmomente kann zu Schäden führen!
- Überprüfen Sie die richtige Stellung des Kunststoffsockels und ob dieser ordnungsgemäß am Schrank befestigt wurde.

EN

Notes on documentation

The assembly instructions are aimed at personnel who have completed corresponding technical training and are thus qualified to set up bases/plinths with electrical, electronic, mechanical and pneumatic equipment in accordance with applicable standards and to erect, assemble and connect such bases/plinths at the place of use.

Associated documents

Assembly instructions exist as a paper document for the equipment described here and are enclosed with the product. We cannot accept any liability for damage associated with failure to observe these instructions or the instructions of any accessories used.

Safety notes



Danger!
Immediate danger to life and limb.

The base/plinth can be used with the following product series:

- TS
- SE
- PC

Assembly and siting

- It is imperative to bolt the base/plinth (e.g. when installed under enclosures/conssoles/stand systems) to the floor to prevent possible tilting. An additional wall fixing of the mounted equipment can be provided by way of a wall bracket.
- Enclosure/console/stand systems and operating housings with a fitted base/plinth must be secured at all times by suitable means to prevent them from tipping over, particularly during transportation, assembly, dismantling and machining. Full details can be found in the instructions for each enclosure system. During transportation, including lifting and setting down, care must be taken to ensure that the load is always resting on the base/plinth corner pieces and never on the base/plinth trim panels.

Before assembly, ensure that:

- the ambient temperature at the site is not higher than +80°C.
- the ambient temperature at the site is not lower than -40°C.
- the base/plinth stands level after construction. Any unevenness at the site can be compensated by way of levelling feet.

Notes on assembly

- Observe the load specifications given on page 12.
- Observe all specified tightening torques. If screws or bolts are tightened with torques greater or less than those specified in these instructions, this may result in damage.
- Check that the plastic base/plinth is positioned correctly and properly fastened to the enclosure.

F

Remarques relatives à la documentation

La notice de montage s'adresse à toutes les personnes qui possèdent la formation technique suffisante pour le montage, l'installation sur site et le raccordement de socles selon les normes électriques, électroniques, mécaniques et pneumatiques en vigueur.

Autres documents applicables

La notice de montage pour les socles décrits dans le présent document est livrée sous forme papier avec le produit. Nous déclinons toute responsabilité en cas de dommages imputables à la non-observation des instructions contenues dans ce document. En complément, il faut également tenir compte des notices pour les accessoires utilisés.

Consignes de sécurité



Attention, danger !
Risque de blessures graves, voire mortelles.

Le socle est prévu pour être associé aux produits suivants :

- TS
- SE
- PC

Montage et implantation

- Afin d'éviter tout basculement du socle et des composants qu'il soutient (ex : armoires électriques, pupitres, pieds ou coffrets de commande), il faut absolument le fixer au sol. Une fixation supplémentaire des composants montés peut être réalisée à l'aide de pattes de fixation murales.
- Les armoires électriques / pupitres / pieds et coffrets de commande équipés de socle doivent toujours être empêchées de basculer en prenant les mesures appropriées, en particulier lors du transport, du montage, du démontage et de l'usinage. Il faut aussi tenir compte des instructions notées dans les notices de montage de chaque produit. Lors des phases de transport ou de levage et de dépose, il faut veiller que le poids ne réside pas sur les plaques de socle mais bien sur les pièces d'angle du socle.

Avant le montage, il faut s'assurer que :

- la température ambiante sur le site d'implantation ne soit pas supérieure à +80°C.
- la température ambiante sur le site d'implantation ne soit pas inférieure à -40°C.
- le socle soit plan après son implantation. Les éventuelles irrégularités du sol du site d'implantation peuvent être corrigées grâce aux pieds de nivellement.

Consignes de montage

- Veuillez respecter les indications de charge qui figurent en page 12.
- Veuillez respecter les indications sur les couples de serrage. Des couples de serrage supérieurs ou inférieurs aux indications de cette notice peuvent provoquer des dommages sur l'installation.
- Vérifiez la position du socle plastique et si celui-ci est correctement fixé à l'armoire.

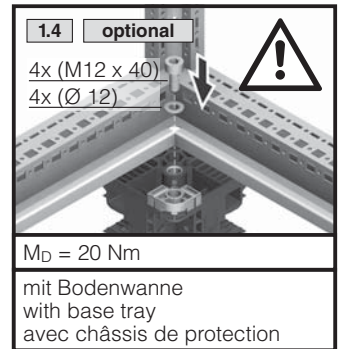
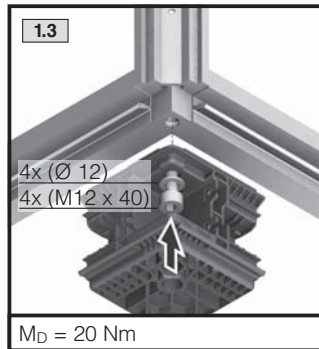
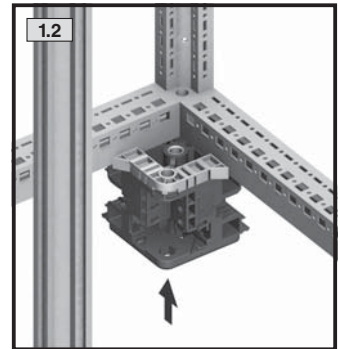
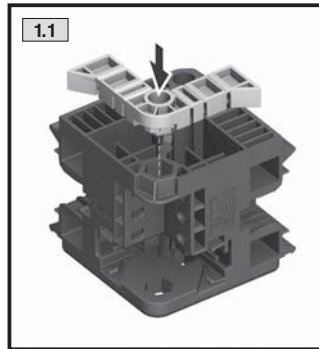
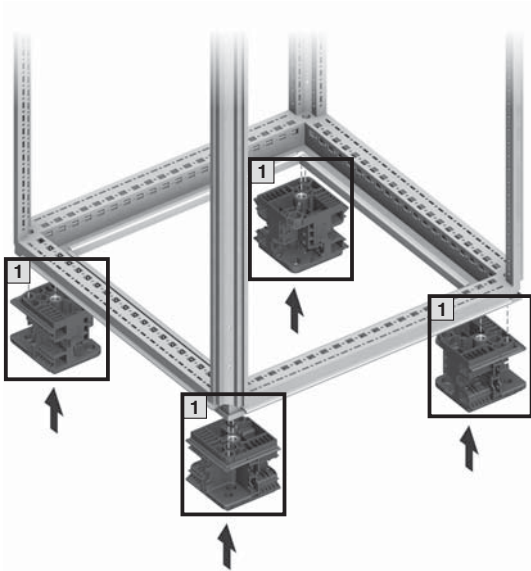

Verschraubung **1.4** nur für statische Endanwendung am Aufstellort zulässig. Bei Transport etc. sind weitere Maßnahmen zur Sicherung gegen Kippen gemäß Montageanleitung des Sockels und des verwendeten Schrankes zu beachten.

Screw fastening **1.4** is only admissible for static final application at the installation site. During transportation etc., further measures should be taken to protect the enclosure against tipping over as per the assembly instructions of the base/plinth and the enclosure used.

Vissage **1.4** uniquement admis pour une mise en œuvre statique sur le lieu d'implantation. Pour le transport, etc., il faut mettre en œuvre d'autres mesures pour empêcher le basculement, conformément à la notice de montage du socle et de l'armoire utilisée.

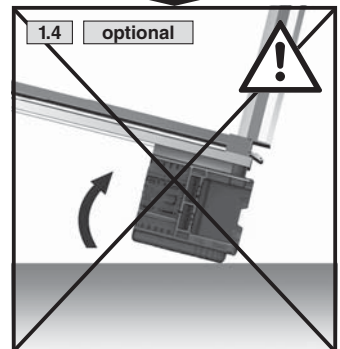

TS 8	TS 8/SE 8
<p>4 x</p>	<p>4 x</p>
<p>TS 8 ohne Bodenwanne TS 8 without base tray TS 8 sans châssis de protection</p>	<p>TS 8 mit Bodenwanne TS 8 with base tray TS 8 avec châssis de protection</p>

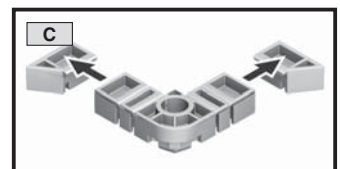
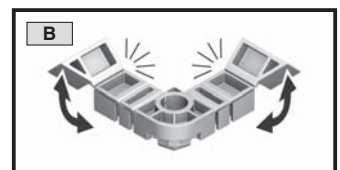
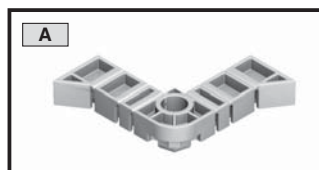

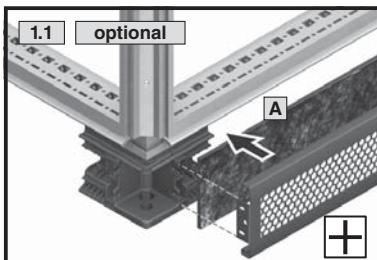
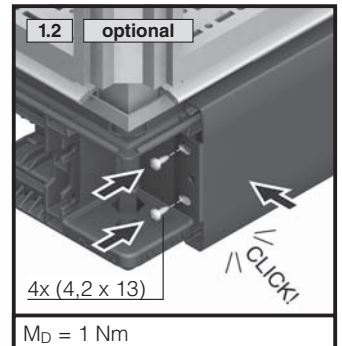
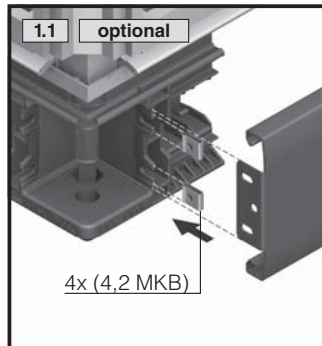
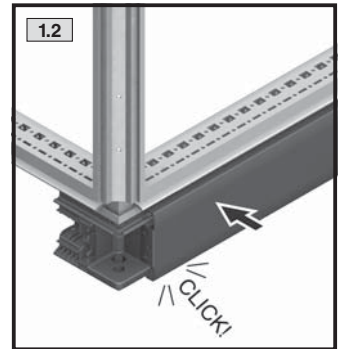
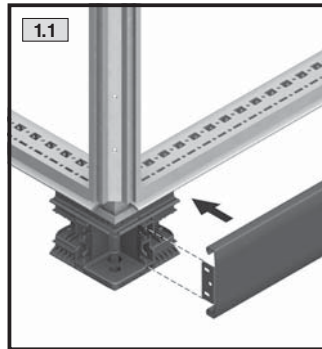
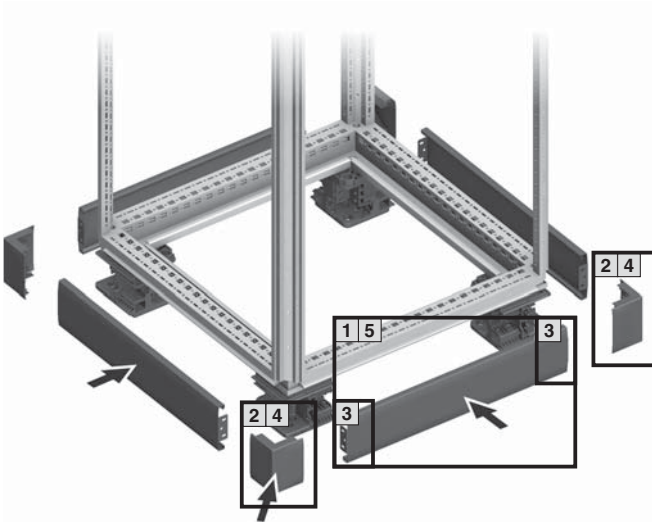
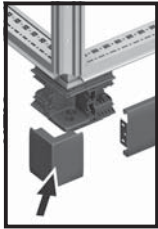

bei Sockel, belüftet
with base/plinth, vented
avec socle ajouré

Für Breite For width Pour largeur	VE (St.) Packs of UE (p.)	Best.-Nr. Model No. Référence TS
A 600/800	4	7583.500

Erdung* Earthing* Mise à la terre*



*Falls Erdung erforderlich, ist diese kundenseitig durchzuführen!
*If earthing is required, this should be provided by the customer!
*Si une mise à la terre est nécessaire, celle-ci doit être effectuée par le client !

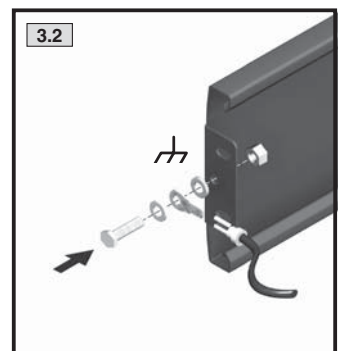
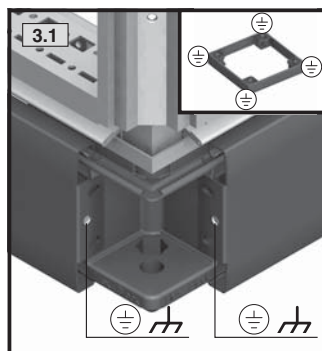
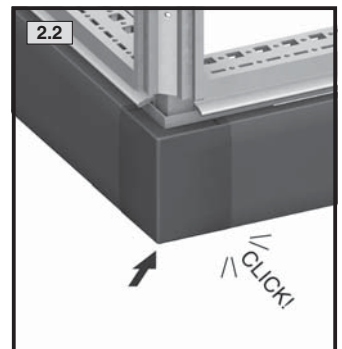
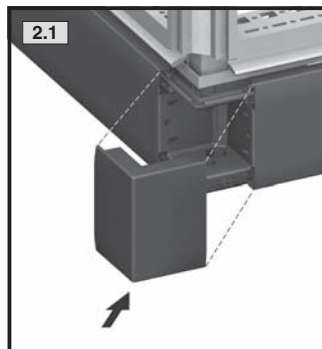

Demontage Dismantling Démontage

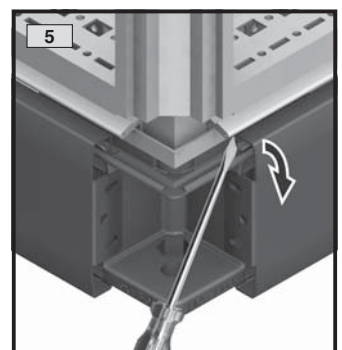
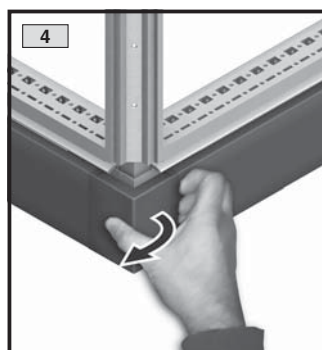

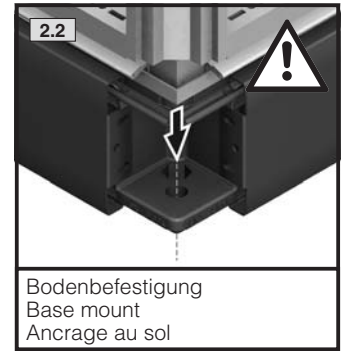
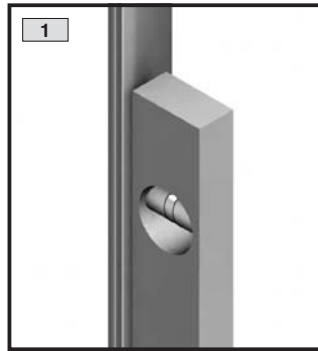
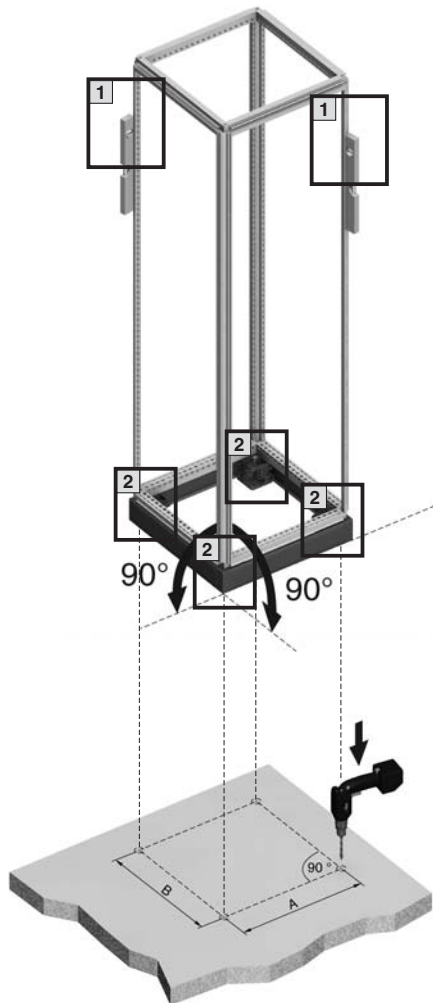
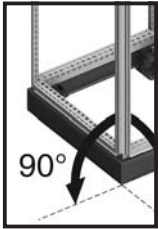

Bodenbefestigung
Base mount
Ancrage au sol

Nennmaß Nominal size Valeur nominale	A/B mm
300	235
400	335
500	435
600	535
800	735
1000	935
1200	1135
1600	1535
1800	1735

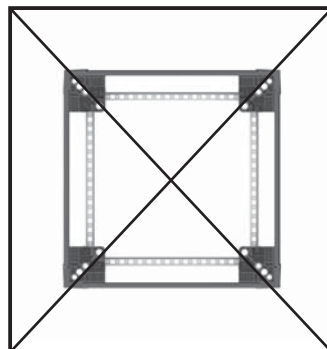
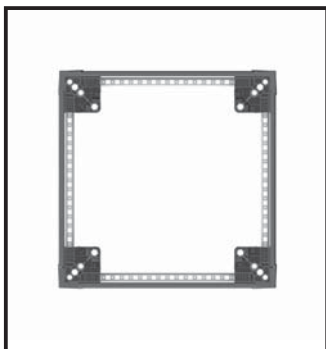
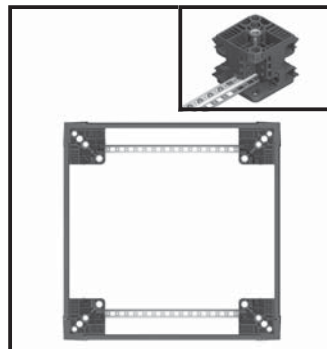
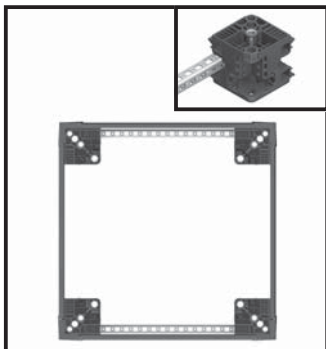
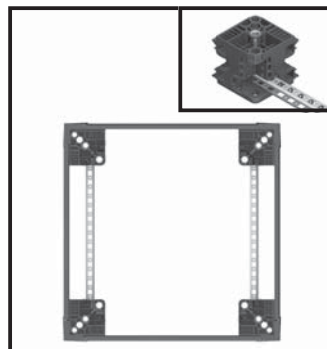
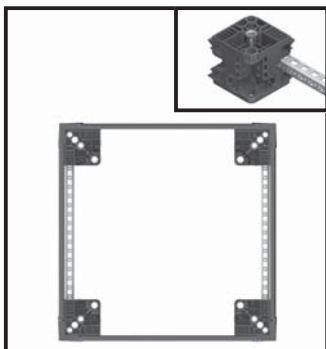
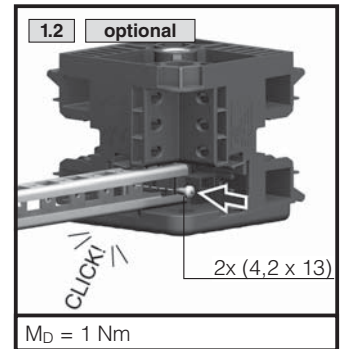
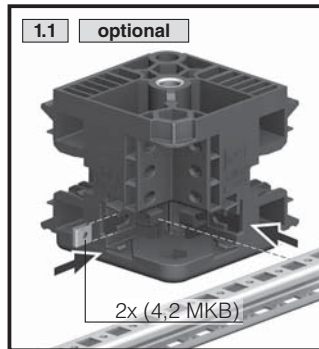
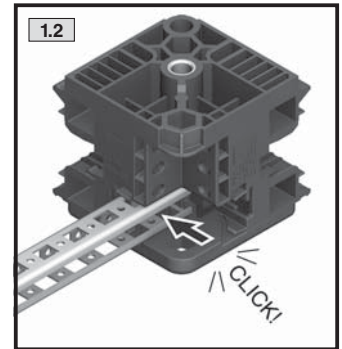
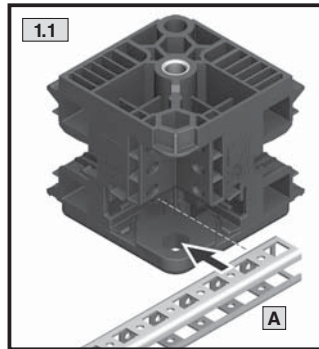
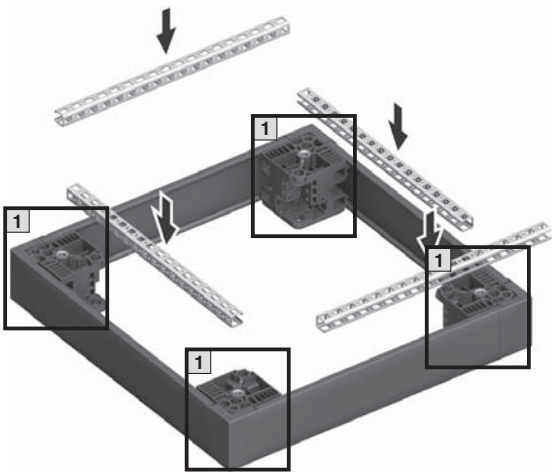
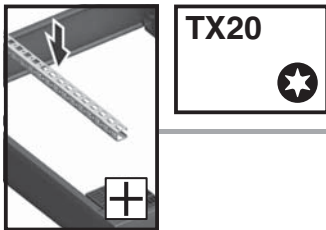

Länge mm Length mm Longueur mm	Für Breite/Tiefe mm For width/depth mm Pour largeur/profondeur mm	VE (St.) Packs of UE (p.)	Best.-Nr. Model No. Référence TS
245	400	12	4169.500
345	500	12	4170.500
445	600	12	4171.500
645	800	12	4172.500

A

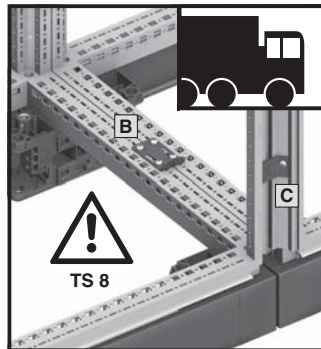
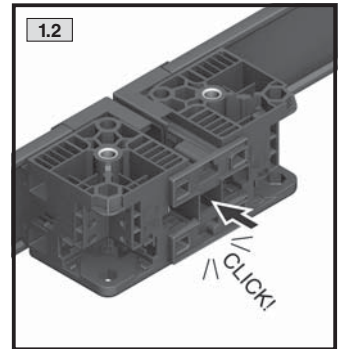
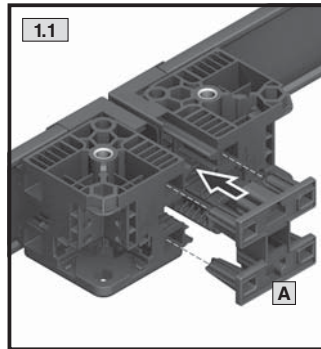
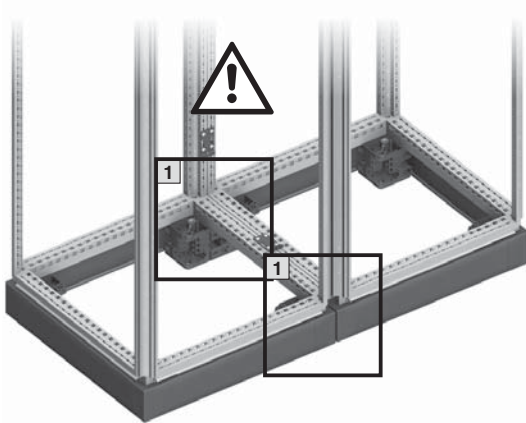
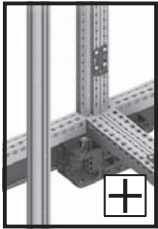

	VE (St.) Packs of UE (p.)	Best.-Nr. Model No. Référence TS
A	12	8000.100
B	6	8800.500
C	6	8800.490

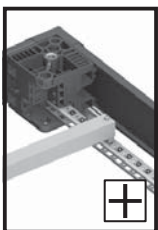

TX30

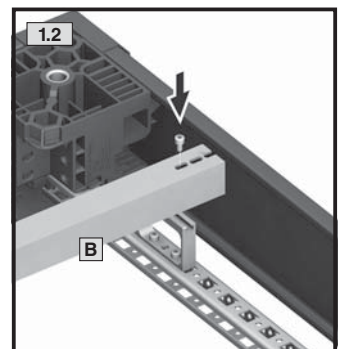
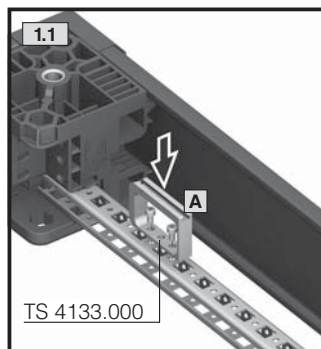
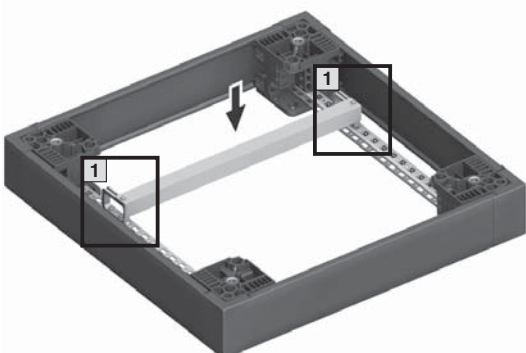

	VE (St.) Packs of UE (p.)	Best.-Nr. Model No. Référence TS
A	12	4133.000

	Länge mm Length mm Longueur mm	Für Breite/Tiefe mm For width/depth mm Pour largeur/profondeur mm	VE (St.) Packs of UE (p.)	Best.-Nr. Model No. Référence TS
	385	400	2	4193.000
	585	600	2	4191.000
	785	800	2	4192.000
B	985	1000	2	4336.000
	1185	1200	2	4196.000
	1585	1600	2	4338.000
	1785	1800	2	4339.000

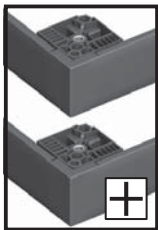

SW8

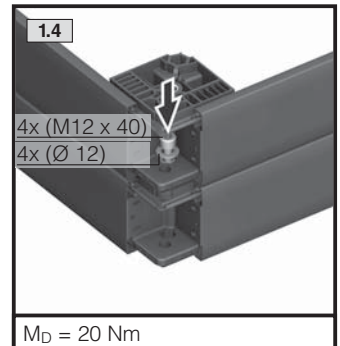
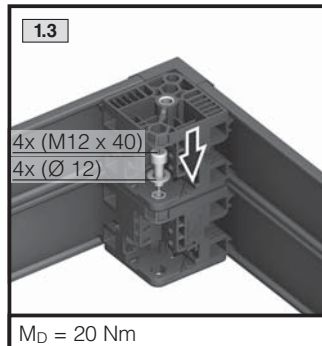
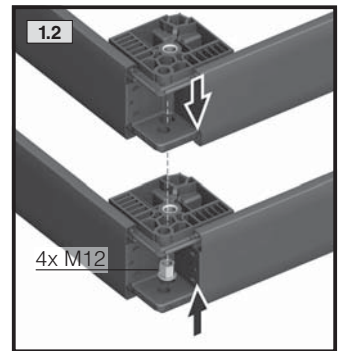
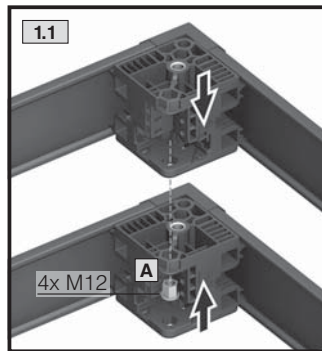
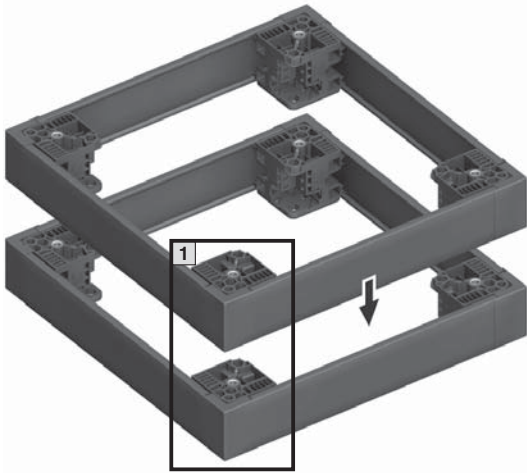
	VE (St.) Packs of UE (p.)	Best.-Nr. Model No. Référence TS
A	12	8000.500

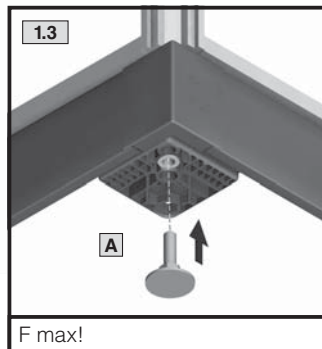
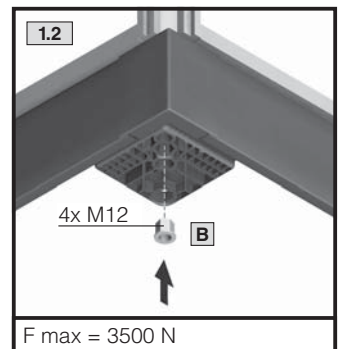
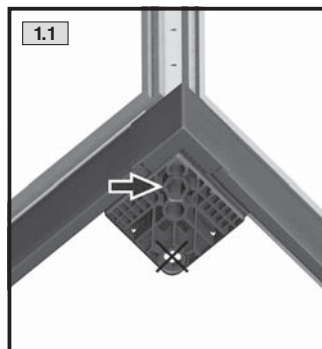
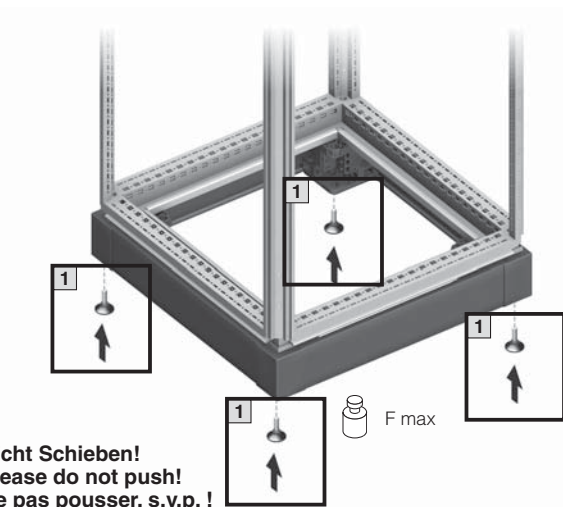

	VE (St.) Packs of UE (p.)	Best.-Nr. Model No. Référence
A	4	4612.000
B	12	8000.500



Nicht Schieben!
Please do not push!
Ne pas pousser, s.v.p. !

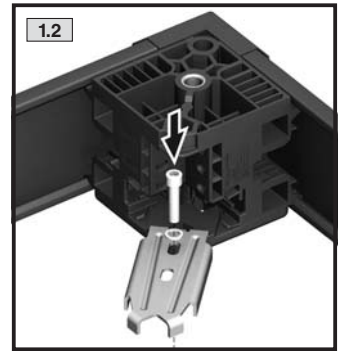
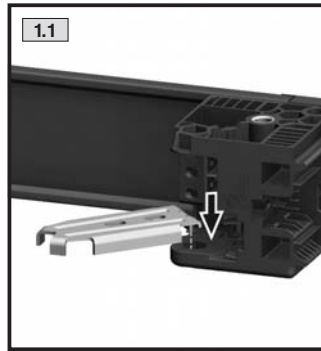

VE (St.) Packs of UE (p.)	Best.-Nr. Model No. Référence TS
A 10	2817.000

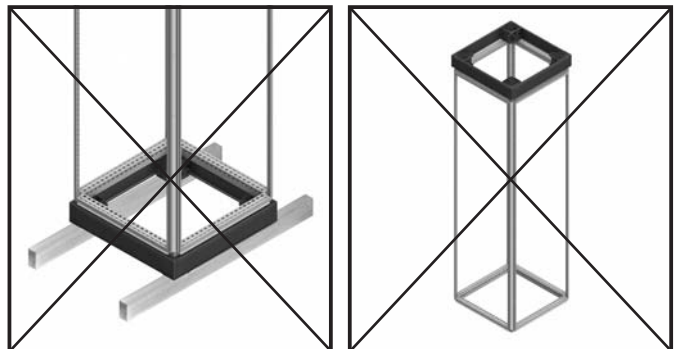
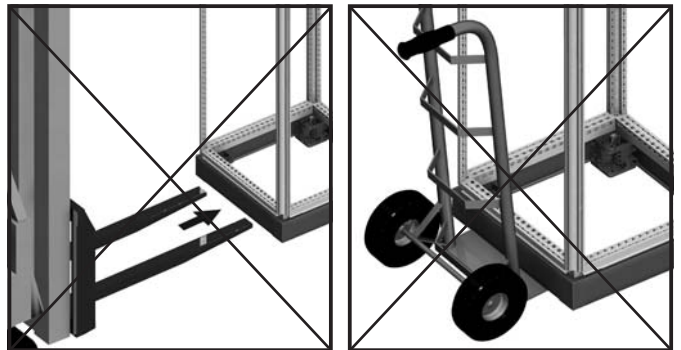
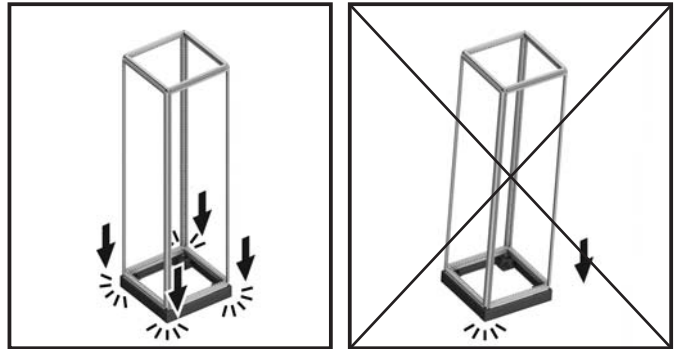
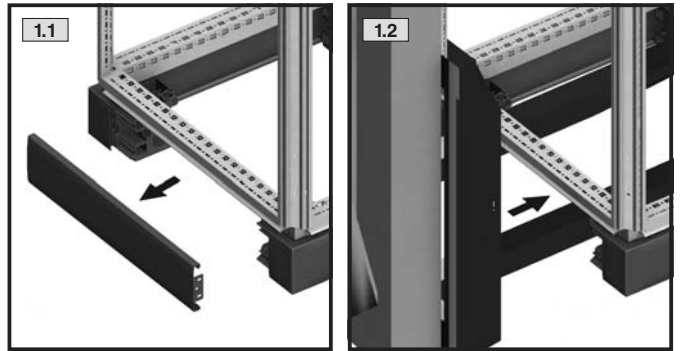
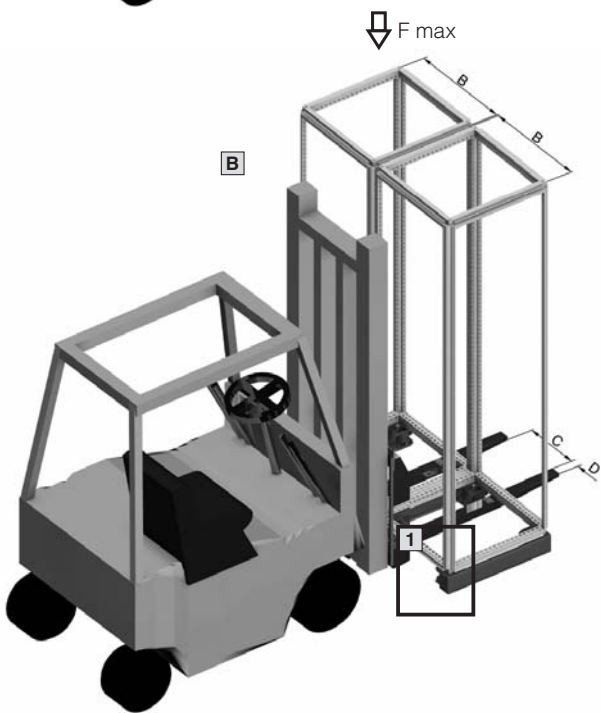
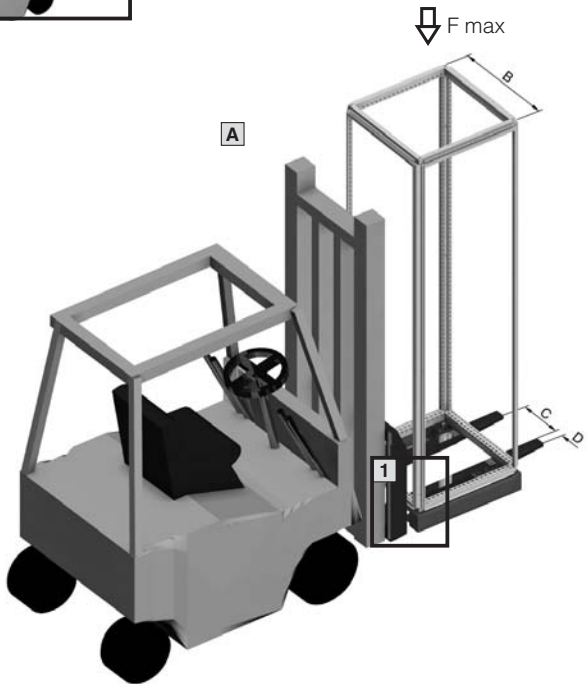

	\Downarrow F max (N)	B mm	C mm	D mm
	7500	600	200	160
	9000	800	200	160
A	3000	1000	200	160
	9000	1000	560	100
	3000	1200	200	160
	9000	1200	760	100

	\Downarrow F max (N)	B mm	C mm	D mm
B	15000	600	330	160
	9000	800	330	160



Chemikalienbeständigkeit für Flex-Block Eckstücke Chemical resistance for Flex-Block corner pieces Résistance chimique des pièces d'angle Flex-Block

Material: PA 6 GF 30 (Lagerung bei Raumtemperatur) ¹⁾
Material: PA 6 GF 30 (storage at room temperature) ¹⁾
Matériau : PA 6 GF 30 (stockage à température ambiante) ¹⁾

Medium Medium Produit	Bewertung/Assessment/Estimation				Bemerkung Comment Remarque
	beständig résistant	bedingt beständig limited resistance résistance limitée	nicht beständig non-resistant non résistant	löslich soluble soluble	
Kohlenwasserstoffe/Hydrocarbons/Hydrocarbures					
Benzol/Benzol/Benzène	■	-	-	-	-
Heizöl, EL, M, S/Heating oil: EL, M, S/Fioul, extra léger, mi-lourd, lourd	■	-	-	-	-
Hexan/Hexane/Hexane	■	-	-	-	-
Motorenöl/Engine oil/Huile pour moteurs	■	-	-	-	-
Toluol/Toluol/Toluène	■	-	-	-	-
Waschbenzin, Kp 100 – 140 °C/ Petroleum ether (white spirit), bp 100 – 140 °C/ Éther de pétrole (white spirit), Kp 100 – 140 °C	■	-	-	-	-
Alkohole/Alcohols/Alcools					
Ethylalkohol, konzentriert (Ethanol)/Ethyl alcohol, concentrated (ethanol)/Alcool éthylique, concentré (éthanol)	-	■	-	-	-
Glycerin/Glycerol/Glycérine	■	-	-	-	-
Glykol, Ethylenglykol/Glycol, ethylene glycol/Glycol, éthylène glycol	-	■	-	-	-
Phenol/Phenol/Phénol	-	-	-	■	-
Ketone/Ketones/Cétones					
Aceton/Acetone/Acétone	■	-	-	-	-
Säuren/Acids/Acides					
Chlorwasserstoff/Hydrogen chloride/Gaz chlorhydrique	-	-	■	-	-
Essigsäure, 30 %ig/Acetic acid, 30%/Acide acétique, 30%	-	-	■	-	-
Milchsäure/Lactic acid/Acide lactique	■	-	-	-	-
Natriumhypochlorit (Bleichlauge)/ Sodium hypochlorite (bleaching lye)/ Hypochlorite de sodium (eau de Javel)	-	-	■	-	-
Natriumthiosulfatlösung, 200g/l/ Sodium thiosulfate solution, 200 g/l/ Solution de thiosulfate de sodium, 200g/l	■	-	-	-	-
Ölsäure, handelsüblich/ Oleic acid, commercially available/ Acide oléique, usuel dans le commerce	■	-	-	-	-
Phosphorsäure, 30 %ig/Phosphoric acid, 30%/Acide phosphorique, 30%	-	-	■	-	-
Salpetersäure, 50 %ig/Nitric acid, 50%/Acide nitrique, 50%	-	-	■	-	-
Salzsäure, konzentriert/Hydrochloric acid, concentrated/Acide chlorhydrique, concentré	-	-	-	■	-
Schwefelsäure, 30 %ig/Sulphuric acid, 30%/Acide sulfurique, 30%	-	-	■	-	-
Basen/Bases/Bases					
Ammoniak, flüssig/Ammonia, liquid/Ammoniac, liquide	■	-	-	-	-
Anilin/Aniline/Aniline	-	■	-	■	Quellung Swelling Gonflement
Natronlauge, 10 %ig, wässrig/Sodium hydroxide solution, 10%, aqueous/Soude caustique, 10%, aqueuse	■	-	-	-	-
Halogene/Halogens/Halogènes					
Brom/Bromine/Brome	-	-	■	-	-
Jodtinktur, handelsüblich/Tincture of iodine, commercial/ Teinture d'iode, usuelle dans le commerce	-	-	■	-	-
Öle, Fette/Oils and greases/Huiles, graisses					
Buttersäure, konzentriert/Butyric acid, concentrated/ Acide butyrique, concentré	-	-	■	-	-
Buttersäure, wässrig/Butyric acid, aqueous/ Acide butyrique, aqueux	■	-	-	-	-
Salzlösungen/Salt solutions/Solutions salines					
Meerwasser/Seawater/Eau de mer	■	-	-	-	-
Natriumcarbonat, gesättigte Lösung/Sodium carbonate, saturated solution/Carbonate de sodium, solution saturée	■	-	-	-	-

¹⁾ Technische Änderungen vorbehalten. Alle Angaben beziehen sich auf den verwendeten Kunststoff.

¹⁾ We reserve the right to make technical modifications. All details refer to the plastic used.

¹⁾ Sous réserve de modifications techniques. Toutes les indications se réfèrent à la matière plastique utilisée.



Chemikalienbeständigkeit für Flex-Block Abdeckkappen Chemical resistance for Flex-Block cover caps Résistance chimique des capots de recouvrement Flex-Block

Material: Pc/ABS 65/35 (Lagerung bei Raumtemperatur) ¹⁾
Material: Pc/ABS 65/35 (storage at room temperature) ¹⁾
Matériau : Pc/ABS 65/35 (stockage à température ambiante) ¹⁾

Medium Medium Produit	Bewertung/Assessment/Estimation		
	beständig resistant résistant	bedingt beständig limited resistance résistance limitée	nicht beständig non-resistant non résistant
Kohlenwasserstoffe/Hydrocarbons/Hydrocarbures			
Benzol/Benzol/Benzène	-	-	■
Heizöl/Heating oil/Fioul	-	■	-
n-Hexan/n-hexane/n-hexane	-	■	-
Toluol/Toluol/Toluène	-	-	■
Waschbenzin, aromafrei/Petroleum ether (white spirit), free of aromatics/ Éther de pétrole (white spirit), sans arôme	-	■	-
Alkohole/Alcohols/Alcools			
Ethylalkohol, 96 %ig/Ethyl alcohol, 96%/Alcool éthylique, 96%	-	■	-
Glycerin/Glycerol/Glycérine	-	■	-
Glykol/Glycol/Glycol	-	■	-
Phenol/Phenol/Phénol	-	-	■
Ketone/Ketones/Cétones			
Aceton/Acetone/Acétone	-	-	■
Säuren/Acids/Acides			
Essigsäure, 10 %ig/Acetic acid, 10%/Acide acétique, 10%	■	-	-
Milchsäure, 10 %ig/Lactic acid, 10%/Acide lactique, 10%	■	-	-
Ölsäure/Oleic acid/Acide oléique	-	-	■
Phosphorsäure, 30 %ig/Phosphoric acid, 30%/Acide phosphorique, 30%	■	-	-
Salpetersäure, 10 %ig/Nitric acid, 10%/Acide nitrique, 10%	■	-	-
Salzsäure, 20 %ig/Hydrochloric acid, 20%/Acide chlorhydrique, 20%	■	-	-
Schwefelsäure, 30 %ig/Sulphuric acid, 30%/Acide sulfurique, 30%	■	-	-
Basen/Bases/Bases			
Ammoniaklösung, verdünnt/Ammonia solution, diluted/Solution d'ammoniac, diluée	-	-	■
Anilin/Aniline/Aniline	-	-	■
Natronlauge, 10 %ig/Sodium hydroxide solution, 10%/Soude caustique, 10%	-	-	■
Halogene/Halogens/Halogènes			
Brom/Bromine/Brome	-	-	■
Chlor/Chlorine/Chlore	-	-	■
Jod/Iodine/Iode	-	-	■
Öle, Fette/Oils and greases/Huiles, graisses			
Buttersäure/Butyric acid/Acide butyrique	-	-	■
Salzlösungen/Salt solutions/Solutions salines			
Kaliumcarbonat, ges./Potassium carbonate, saturated/Carbonate de potassium, saturé	-	-	■
Meerwasser/Seawater/Eau de mer	■	-	-
Natriumhypochlorid/Sodium hypochlorite/Hypochlorite de sodium	■	-	-
Natriumthiosulfat/Sodium thiosulfate/Thiosulfate de sodium	■	-	-

¹⁾ Technische Änderungen vorbehalten. Alle Angaben beziehen sich auf den verwendeten Kunststoff.

¹⁾ We reserve the right to make technical modifications. All details refer to the plastic used.

¹⁾ Sous réserve de modifications techniques. Toutes les indications se réfèrent à la matière plastique utilisée.

Notizen/Notes/Notices



Rittal – The System.

Faster – better – everywhere.

- Enclosures
- Power Distribution
- Climate Control
- IT Infrastructure
- Software & Services

RITTAL GmbH & Co. KG
Postfach 1662 · D-35726 Herborn
Phone + 49(0)2772 505-0 · Fax + 49(0)2772 505-2319
E-mail: info@rittal.de · www.rittal.com

ENCLOSURES

POWER DISTRIBUTION

CLIMATE CONTROL

IT INFRASTRUCTURE

SOFTWARE & SERVICES

FRIEDHELM LOH GROUP

