

PCA9306 Dual Bidirectional I²C Bus and SMBus Voltage-Level Translator

1 Features

- 2-Bit Bidirectional Translator for SDA and SCL Lines in Mixed-Mode I²C Applications
- I²C and SMBus Compatible
- Less Than 1.5-ns Maximum Propagation Delay to Accommodate Standard-Mode and Fast-Mode I²C Devices and Multiple Masters
- Allows Voltage-Level Translation Between
 - 1.2-V V_{REF1} and 1.8-V, 2.5-V, 3.3-V, or 5-V V_{REF2}
 - 1.8-V V_{REF1} and 2.5-V, 3.3-V, or 5-V V_{REF2}
 - 2.5-V V_{REF1} and 3.3-V or 5-V V_{REF2}
 - 3.3-V V_{REF1} and 5-V V_{REF2}
- Provides Bidirectional Voltage Translation With No Direction Pin
- Low 3.5-Ω ON-State Connection Between Input and Output Ports Provides Less Signal Distortion
- Open-Drain I²C I/O Ports (SCL1, SDA1, SCL2, and SDA2)
- 5-V Tolerant I²C I/O Ports to Support Mixed-Mode Signal Operation
- High-Impedance SCL1, SDA1, SCL2, and SDA2 Pins for EN = Low
- Lock-Up-Free Operation for Isolation When EN = Low
- Flow-Through Pinout for Ease of Printed Circuit Board Trace Routing
- Latch-Up Performance Exceeds 100 mA Per JESD 78, Class II
- ESD Protection Exceeds JESD 22
 - 2000-V Human-Body Model (A114-A)
 - 200-V Machine Model (A115-A)
 - 1000-V Charged-Device Model (C101)

2 Applications

- I²C, SMBus, PMBus, MDIO, UART, Low-Speed SDIO, GPIO, and Other Two-Signal Interfaces
- Servers
- Routers (Telecom Switching Equipment)
- Personal Computers
- Industrial Automation

3 Description

The PCA9306 is a dual bidirectional I²C and SMBus voltage-level translator, with an enable (EN) input, is operational from 1.2-V to 3.3-V V_{REF1} and 1.8-V to 5.5-V V_{REF2} .

The PCA9306 allows bidirectional voltage translations between 1.2 V and 5 V, without the use of a direction pin. The low ON-state resistance (R_{ON}) of the switch allows connections to be made with minimal propagation delay. When EN is high, the translator switch is ON, and the SCL1 and SDA1 I/O are connected to the SCL2 and SDA2 I/O, respectively, allowing bidirectional data flow between ports. When EN is low, the translator switch is off, and a high-impedance state exists between ports.

In addition to voltage translation, the PCA9306 can be used to isolate a 400-kHz bus from a 100-kHz by controlling the EN pin.

Device Information⁽¹⁾

PART NUMBER	PACKAGE	BODY SIZE (NOM)
PCA9306	SSOP (8)	2.95 mm x 2.80 mm
	VSSOP (8)	2.30 mm x 2.30 mm
	X2SON (8)	1.40 mm x 1.00 mm
	DSBGA (8)	1.90 mm x 0.90 mm

(1) For all available packages, see the orderable addendum at the end of the datasheet.

Simplified Application Diagram

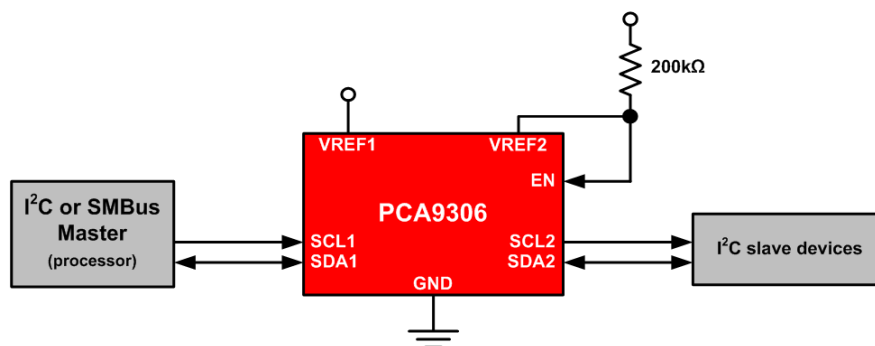

Table of Contents

1 Features 1 2 Applications 1 3 Description 1 4 Revision History 2 5 Pin Configuration and Functions 3 6 Specifications 4 6.1 Absolute Maximum Ratings 4 6.2 Handling Ratings..... 4 6.3 Recommended Operating Conditions..... 4 6.4 Thermal Information 4 6.5 Electrical Characteristics..... 4 6.6 Switching Characteristics AC Performance (Translating Down) (EN = 3.3 V) 5 6.7 Switching Characteristics AC Performance (Translating Down) (EN = 2.5 V) 5 6.8 Switching Characteristics AC Performance (Translating Up) (EN = 3.3 V) 5 6.9 Switching Characteristics AC Performance (Translating Up) (EN = 2.5 V) 6 6.10 Typical Characteristics 6	7 Parameter Measurement Information 7 8 Detailed Description 8 8.1 Overview 8 8.2 Functional Block Diagram 8 8.3 Feature Description..... 8 8.4 Device Functional Modes..... 9 9 Application and Implementation 10 9.1 Application Information..... 10 9.2 Typical Application 10 10 Power Supply Requirements 14 11 Layout 14 11.1 Layout Guidelines 14 11.2 Layout Example 14 12 Device and Documentation Support 15 12.1 Trademarks 15 12.2 Electrostatic Discharge Caution..... 15 12.3 Glossary 15 13 Mechanical, Packaging, and Orderable Information 15
--	--

4 Revision History

NOTE: Page numbers for previous revisions may differ from page numbers in the current version.

Changes from Revision J (October 2010) to Revision K	Page
<ul style="list-style-type: none"> • Added <i>Pin Configuration and Functions</i> section, <i>Handling Rating</i> table, <i>Feature Description</i> section, <i>Device Functional Modes</i>, <i>Application and Implementation</i> section, <i>Power Supply Recommendations</i> section, <i>Layout</i> section, <i>Device and Documentation Support</i> section, and <i>Mechanical, Packaging, and Orderable Information</i> section 	1

5 Pin Configuration and Functions

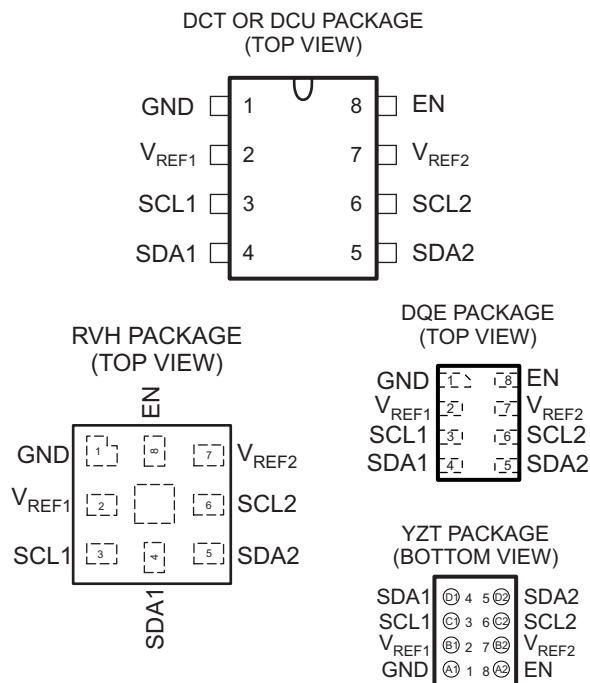

Pin Functions

NAME	PIN		DESCRIPTION
	NO.		
	DCT, DCU, DQE, RVH	YZT	
GND	1	A1	Ground, 0 V
V _{REF1}	2	B1	Low-voltage-side reference supply voltage for SCL1 and SDA1
SCL1	3	C1	Serial clock, low-voltage side
SDA1	4	D1	Serial data, low-voltage side
SDA2	5	D2	Serial data, high-voltage side
SCL2	6	C2	Serial clock, high-voltage side
V _{REF2}	7	B2	High-voltage-side reference supply voltage for SCL2 and SDA2
EN	8	A2	Switch enable input

6 Specifications

6.1 Absolute Maximum Ratings⁽¹⁾

over operating free-air temperature range (unless otherwise noted)

		MIN	MAX	UNIT
V _{REF1}	DC reference voltage range	-0.5	7	V
V _{REF2}	DC reference bias voltage range	-0.5	7	V
V _I	Input voltage range ⁽²⁾	-0.5	7	V
V _{I/O}	Input/output voltage range ⁽²⁾	-0.5	7	V
Continuous channel current			128	mA
I _{IK}	Input clamp current	V _I < 0	-50	mA

- (1) Stresses beyond those listed under *Absolute Maximum Ratings* may cause permanent damage to the device. These are stress ratings only, and functional operation of the device at these or any other conditions beyond those indicated under *Recommended Operating Conditions* is not implied. Exposure to absolute-maximum-rated conditions for extended periods may affect device reliability.
- (2) The input and input/output negative voltage ratings may be exceeded if the input and output current ratings are observed.

6.2 Handling Ratings

		MIN	MAX	UNIT	
T _{stg}	Storage temperature range	-65	150	°C	
V _(ESD)	Electrostatic discharge	Human body model (HBM), per ANSI/ESDA/JEDEC JS-001, all pins ⁽¹⁾	0	2000	V
		Charged device model (CDM), per JEDEC specification JESD22-C101, all pins ⁽²⁾	0	1000	

- (1) JEDEC document JEP155 states that 500-V HBM allows safe manufacturing with a standard ESD control process.
- (2) JEDEC document JEP157 states that 250-V CDM allows safe manufacturing with a standard ESD control process.

6.3 Recommended Operating Conditions

		MIN	MAX	UNIT
V _{I/O}	Input/output voltage	SCL1, SDA1, SCL2, SDA2		V
V _{REF1}	Reference voltage	0	5.5	V
V _{REF2}	Reference voltage	0	5.5	V
EN	Enable input voltage	0	5.5	V
I _{PASS}	Pass switch current		64	mA
T _A	Operating free-air temperature	-40	85	°C

6.4 Thermal Information

THERMAL METRIC ⁽¹⁾	PCA9306				UNIT	
	DCT	DCU	DQE	YZT		
	8 PINS	8 PINS	8 PINS	8 PINS		
R _{θJA}	Junction-to-ambient thermal resistance	189.6	210.1	246.5	125.5	°C/W
R _{θJC(top)}	Junction-to-case (top) thermal resistance	119.6	81.9	149.1	1.0	
R _{θJB}	Junction-to-board thermal resistance	102.1	88.8	100.0	62.7	
ψ _{JT}	Junction-to-top characterization parameter	44.5	8.3	17.1	3.4	
ψ _{JB}	Junction-to-board characterization parameter	101.0	88.4	99.8	62.7	

- (1) For more information about traditional and new thermal metrics, see the *IC Package Thermal Metrics* application report, [SPRA953](#).

6.5 Electrical Characteristics

over recommended operating free-air temperature range (unless otherwise noted)

PARAMETER	TEST CONDITIONS	MIN	TYP ⁽¹⁾	MAX	UNIT
V _{IK}	Input clamp voltage	I _I = -18 mA, EN = 0 V		-1.2	V

- (1) All typical values are at T_A = 25°C.

Electrical Characteristics (continued)

over recommended operating free-air temperature range (unless otherwise noted)

PARAMETER		TEST CONDITIONS		MIN	TYP ⁽¹⁾	MAX	UNIT	
I_{IH}	Input leakage current	$V_I = 5\text{ V}$, $EN = 0\text{ V}$				5	μA	
$C_{i(EN)}$	Input capacitance	$V_I = 3\text{ V}$ or 0			11		pF	
$C_{io(off)}$	Off capacitance	SCLn, SDA _n	$V_O = 3\text{ V}$ or 0, $EN = 0\text{ V}$		4	6	pF	
$C_{io(on)}$	On capacitance	SCLn, SDA _n	$V_O = 3\text{ V}$ or 0, $EN = 3\text{ V}$		10.5	12.5	pF	
$R_{ON}^{(2)}$	On-state resistance	SCLn, SDA _n	$V_I = 0$, $I_O = 64\text{ mA}$	$EN = 4.5\text{ V}$	3.5	5.5	Ω	
				$EN = 3\text{ V}$	4.7	7		
				$EN = 2.3\text{ V}$	6.3	9.5		
				$EN = 1.5\text{ V}$	25.5	32		
			$V_I = 2.4\text{ V}$, $I_O = 15\text{ mA}$	$EN = 4.5\text{ V}$	1	6		15
				$EN = 3\text{ V}$	20	60		140
$V_I = 1.7\text{ V}$, $I_O = 15\text{ mA}$	$EN = 2.3\text{ V}$	20	60	140				

(2) Measured by the voltage drop between the SCL1 and SCL2, or SDA1 and SDA2 terminals, at the indicated current through the switch. ON-state resistance is determined by the lowest voltage of the two terminals.

6.6 Switching Characteristics AC Performance (Translating Down) (EN = 3.3 V)⁽¹⁾

over recommended operating free-air temperature range, $EN = 3.3\text{ V}$, $V_{IH} = 3.3\text{ V}$, $V_{IL} = 0$, $V_M = 1.15\text{ V}$ (unless otherwise noted) (see [Figure 3](#)).

PARAMETER	FROM (INPUT)	TO (OUTPUT)	$C_L = 50\text{ pF}$		$C_L = 30\text{ pF}$		$C_L = 15\text{ pF}$		UNIT
			MIN	MAX	MIN	MAX	MIN	MAX	
t_{PLH}	SCL2 or SDA2	SCL1 or SDA1	0	0.8	0	0.6	0	0.3	ns
t_{PHL}			0	1.2	0	1	0	0.5	

(1) Translating down: the high voltage side driving toward the lower voltage side

6.7 Switching Characteristics AC Performance (Translating Down) (EN = 2.5 V)⁽¹⁾

over recommended operating free-air temperature range, $EN = 2.5\text{ V}$, $V_{IH} = 3.3\text{ V}$, $V_{IL} = 0$, $V_M = 0.75\text{ V}$ (unless otherwise noted) (see [Figure 3](#)).

PARAMETER	FROM (INPUT)	TO (OUTPUT)	$C_L = 50\text{ pF}$		$C_L = 30\text{ pF}$		$C_L = 15\text{ pF}$		UNIT
			MIN	MAX	MIN	MAX	MIN	MAX	
t_{PLH}	SCL2 or SDA2	SCL1 or SDA1	0	1	0	0.7	0	0.4	ns
t_{PHL}			0	1.3	0	1	0	0.6	

(1) Translating down: the high voltage side driving toward the lower voltage side

6.8 Switching Characteristics AC Performance (Translating Up) (EN = 3.3 V)⁽¹⁾

over recommended operating free-air temperature range, $EN = 3.3\text{ V}$, $V_{IH} = 2.3\text{ V}$, $V_{IL} = 0$, $V_T = 3.3\text{ V}$, $V_M = 1.15\text{ V}$, $R_L = 300\ \Omega$ (unless otherwise noted) (see [Figure 3](#)).

PARAMETER	FROM (INPUT)	TO (OUTPUT)	$C_L = 50\text{ pF}$		$C_L = 30\text{ pF}$		$C_L = 15\text{ pF}$		UNIT
			MIN	MAX	MIN	MAX	MIN	MAX	
t_{PLH}	SCL1 or SDA1	SCL2 or SDA2	0	0.9	0	0.6	0	0.4	ns
t_{PHL}			0	1.4	0	1.1	0	0.7	

(1) Translating up: the lower voltage side driving toward the higher voltage side

6.9 Switching Characteristics AC Performance (Translating Up) (EN = 2.5 V)⁽¹⁾

over recommended operating free-air temperature range, EN = 2.5 V, V_{IH} = 2.3 V, V_{IL} = 0, V_T = 3.3 V, V_M = 0.75 V, R_L = 300 Ω (unless otherwise noted) (see Figure 3).

PARAMETER	FROM (INPUT)	TO (OUTPUT)	C _L = 50 pF		C _L = 30 pF		C _L = 15 pF		UNIT
			MIN	MAX	MIN	MAX	MIN	MAX	
t _{PLH}	SCL1 or SDA1	SCL2 or SDA2	0	1	0	0.6	0	0.4	ns
t _{PHL}			0	1.3	0	1.3	0	0.8	

(1) Translating up: the lower voltage side driving toward the higher voltage side

6.10 Typical Characteristics

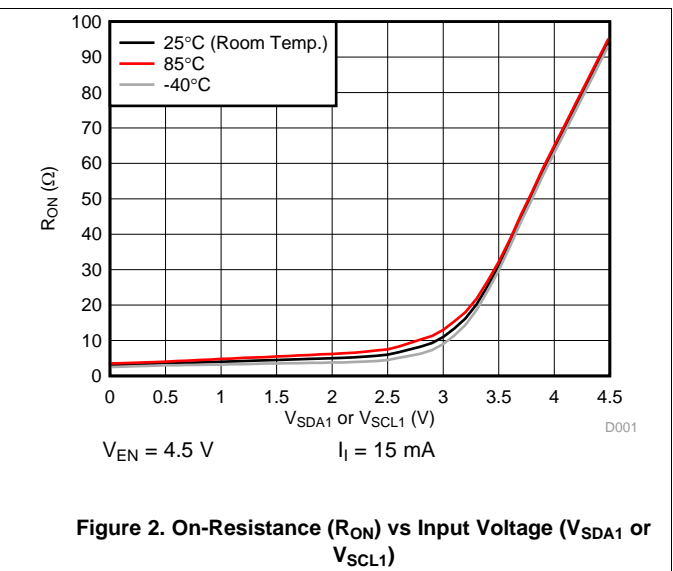
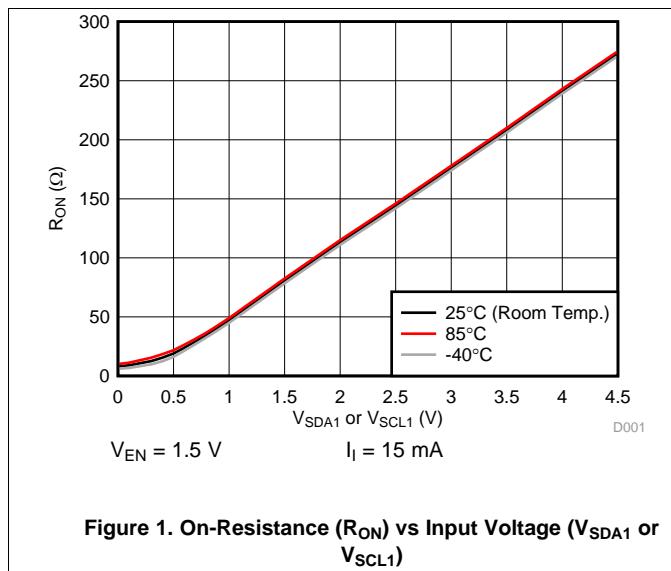

7 Parameter Measurement Information

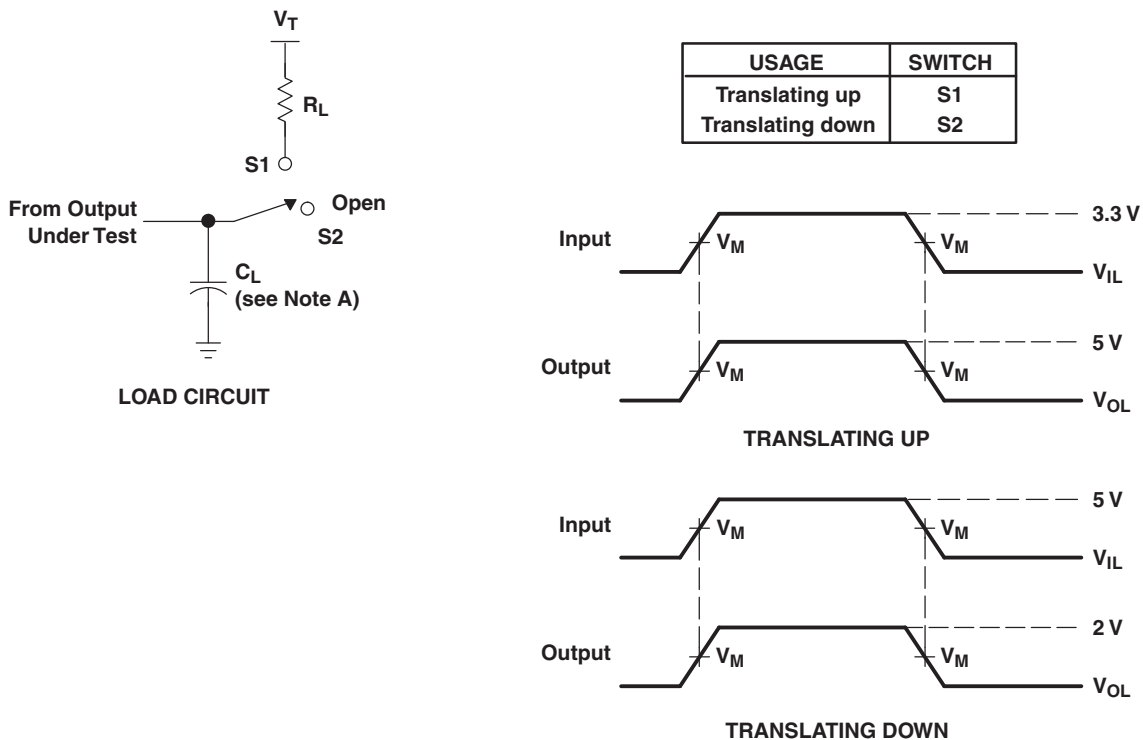

- NOTES: A. C_L includes probe and jig capacitance.
 B. All input pulses are supplied by generators having the following characteristics: $PRR \leq 10\text{ MHz}$, $Z_O = 50\ \Omega$, $t_r \leq 2\text{ ns}$, $t_f \leq 2\text{ ns}$.
 C. The outputs are measured one at a time, with one transition per measurement.

Figure 3. Load Circuit for Outputs

8 Detailed Description

8.1 Overview

The PCA9306 is a dual bidirectional I²C and SMBus voltage-level translator with an enable (EN) input that operates without use of a direction pin. The voltage supply range for V_{REF1} is 1.2 V to 3.3 V and the supply range for V_{REF2} is 1.8 V to 5.5 V.

The PCA9306 can also be used to run two buses, one at 400-kHz operating frequency and the other at 100-kHz operating frequency. If the two buses are operating at different frequencies, the 100-kHz bus must be isolated by using the EN pin when the 400-kHz operation of the main bus is required. If the master is running at 400 kHz, the maximum system operating frequency may be less than 400 kHz because of the delays added by the repeater.

In I²C applications, the bus capacitance limit of 400 pF restricts the number of devices and bus length. The capacitive load on both sides of the PCA9306 must be taken into account when approximating the total load of the system, ensuring the sum of both sides is under 400 pF.

Both the SDA and SCL channels of the PCA9306 have the same electrical characteristics, and there is minimal deviation from one output to another in voltage or propagation delay. This is a benefit over discrete transistor voltage translation solutions, since the fabrication of the switch is symmetrical. The translator provides excellent ESD protection to lower-voltage devices and at the same time protects less ESD-resistant devices.

8.2 Functional Block Diagram

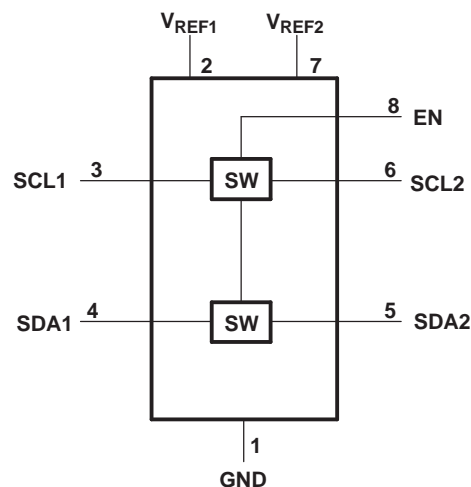

Figure 4. Logic Diagram (Positive Logic)

8.3 Feature Description

8.3.1 Enable (EN) Pin

The PCA9306 is a double pole, single throw switch in which the gate of the transistors is controlled by the voltage on the EN pin. In [Figure 5](#), the PCA9306 will always be enabled when power is applied to V_{REF2} . In [Figure 6](#), the device will be enabled when a control signal from a processor is in a logic high state. In another variation, the EN pin can be controlled by the output of a processor but V_{REF2} can be connected to a power supply through a 200-k Ω resistor. In this case, V_{REF2} and EN shall not be tied together, and the SCL and SDA switches will be in a high impedance state when EN is in a logic low state, as shown in [Device Functional Modes](#)

Feature Description (continued)

8.3.2 Voltage Translation

The primary feature of the PCA9306 is translating voltage from an I²C bus referenced to V_{REF1} up to an I²C bus referenced to V_{DPU} , which V_{REF2} is connected to through a 200-k Ω pull-up resistor. When translating a standard, open-drain I²C bus, this is achieved by simply connecting pull-up resistors from SCL1 and SDA1 to V_{REF1} and connecting pull-up resistors from SCL2 and SDA2 to V_{DPU} . Info on sizing the pull-up resistors can be found in the [Sizing Pullup Resistors](#) section.

8.4 Device Functional Modes

INPUT EN ⁽¹⁾	TRANSLATOR FUNCTION
H	SCL1 = SCL2, SDA1 = SDA2
L	Disconnect

(1) The SCL switch conducts if EN is ≥ 1 V higher than SCL1 or SCL2. The same is true of SDA.

9 Application and Implementation

NOTE

Information in the following applications sections is not part of the TI component specification, and TI does not warrant its accuracy or completeness. TI's customers are responsible for determining suitability of components for their purposes. Customers should validate and test their design implementation to confirm system functionality.

9.1 Application Information

9.1.1 General Applications of I²C

As with the standard I²C system, pull-up resistors are required to provide the logic high levels on the translator's bus. The size of these pull-up resistors depends on the system, but each side of the repeater must have a pull-up resistor. The device is designed to work with standard-mode and fast-mode I²C devices, in addition to SMBus devices. Standard-mode I²C devices only specify 3 mA in a generic I²C system where standard-mode devices and multiple masters are possible. Under certain conditions, high termination currents can be used. When the SDA1 or SDA2 port is low, the clamp is in the ON state, and a low resistance connection exists between the SDA1 and SDA2 ports. Assuming the higher voltage is on the SDA2 port when the SDA2 port is high, the voltage on the SDA1 port is limited to the voltage set by V_{REF1} . When the SDA1 port is high, the SDA2 port is pulled to the drain pull-up supply voltage (V_{DPU}) by the pull-up resistors. This functionality allows a seamless translation between higher and lower voltages selected by the user, without the need for directional control. The SCL1/SCL2 channel also functions in the same way as the SDA1/SDA2 channel.

9.2 Typical Application

Figure 5 and Figure 6 show how these pull-up resistors are connected in a typical application, as well as two options for connecting the EN pin.

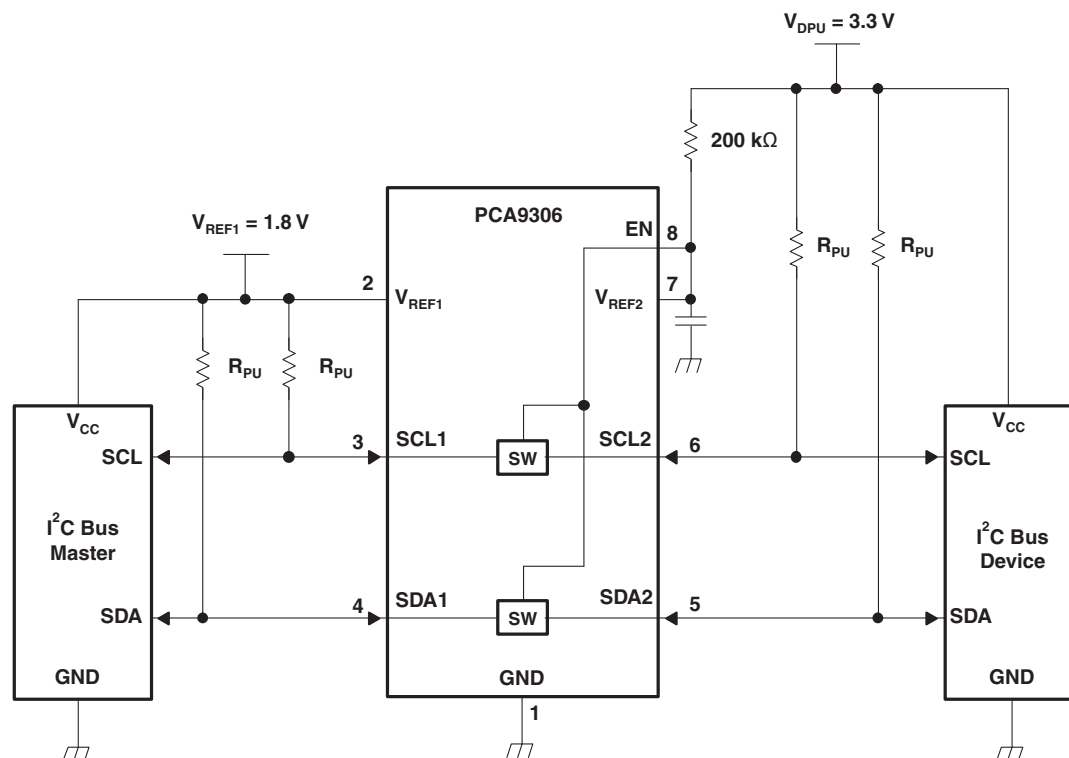

Figure 5. Typical Application Circuit (Switch Always Enabled)

Typical Application (continued)

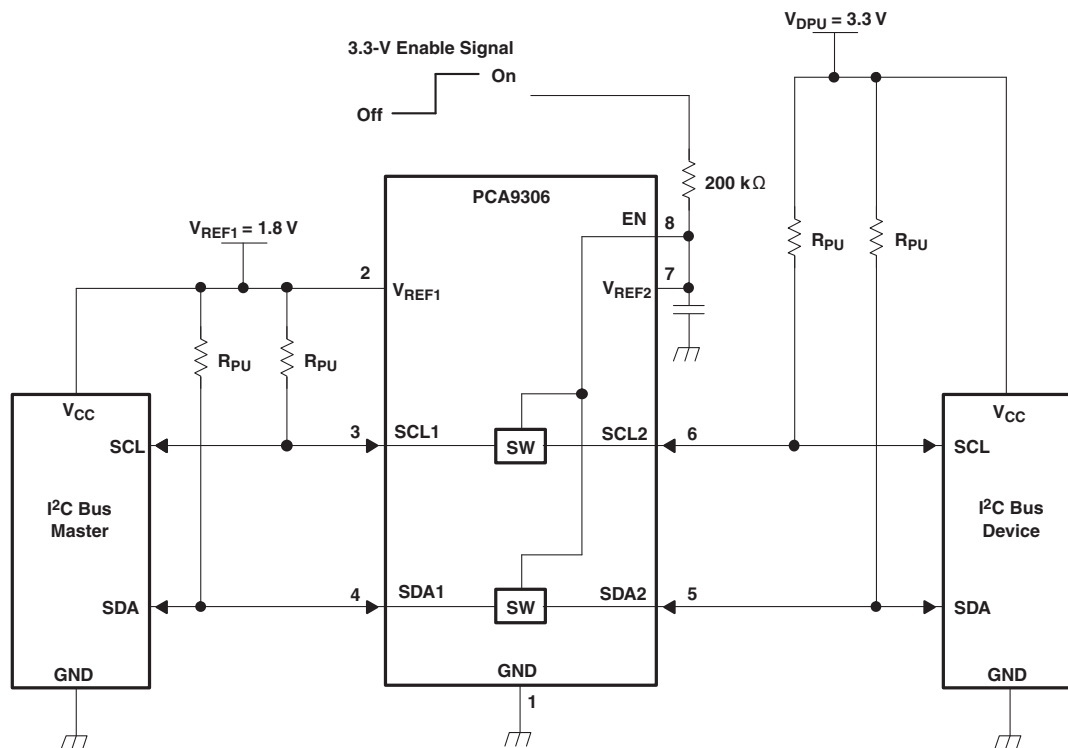

Figure 6. Typical Application Circuit (Switch Enable Control)

9.2.1 Design Requirements

		MIN	TYP ⁽¹⁾	MAX	UNIT
V _{REF2}	Reference voltage	V _{REF1} + 0.6	2.1	5	V
EN	Enable input voltage	V _{REF1} + 0.6	2.1	5	V
V _{REF1}	Reference voltage	0	1.5	4.4	V
I _{PASS}	Pass switch current		14		mA
I _{REF}	Reference-transistor current		5		µA
T _A	Operating free-air temperature	-40		85	°C

(1) All typical values are at T_A = 25°C.

9.2.2 Detailed Design Procedure

9.2.2.1 Bidirectional Voltage Translation

For the bidirectional clamping configuration (higher voltage to lower voltage or lower voltage to higher voltage), the EN input must be connected to V_{REF2} and both pins pulled to high-side V_{DPU} through a pull-up resistor (typically 200 kΩ). This allows V_{REF2} to regulate the EN input. A 100-pF filter capacitor connected to V_{REF2} is recommended. The I²C bus master output can be push-pull or open-drain (pull-up resistors may be required) and the I²C bus device output can be totem pole or open-drain (pull-up resistors are required to pull the SCL2 and SDA2 outputs to V_{DPU}). However, if either output is push-pull, data must be unidirectional or the outputs must be 3-state capable and be controlled by some direction-control mechanism to prevent high-to-low contentions in either direction. If both outputs are open-drain, no direction control is needed.

The reference supply voltage (V_{REF1}) is connected to the processor core power-supply voltage.

9.2.2.2 Sizing pull-up Resistors

The pull-up resistor value needs to limit the current through the pass transistor, when it is in the on state, to about 15 mA. This ensures a pass voltage of 260 mV to 350 mV. If the current through the pass transistor is higher than 15 mA, the pass voltage also is higher in the on state. To set the current through each pass transistor at 15 mA, the pull-up resistor value is calculated as:

$$R_{PU} = \frac{V_{DPU} - 0.35 \text{ V}}{0.015 \text{ A}} \quad (1)$$

Table 1 summarizes resistor values, reference voltages, and currents at 15 mA, 10 mA, and 3 mA. The resistor value shown in the +10% column (or a larger value) should be used to ensure that the pass voltage of the transistor is 350 mV or less. The external driver must be able to sink the total current from the resistors on both sides of the PCA9306 device at 0.175 V, although the 15 mA applies only to current flowing through the PCA9306 device. **Figure 7** and **Figure 8** respectively show the maximum and minimum pull-up resistance allowable by the I²C specification for standard-mode (100 kHz) and fast-mode (400 kHz) operation.

Table 1. Pull-up Resistor Values⁽¹⁾⁽²⁾

V _{DPU}	Pull-up resistor value (Ω)					
	15 mA		10 mA		3 mA	
	NOMINAL	+10% ⁽³⁾	NOMINAL	+10% ⁽³⁾	NOMINAL	+10% ⁽³⁾
5 V	310	341	465	512	1550	1705
3.3 V	197	217	295	325	983	1082
2.5 V	143	158	215	237	717	788
1.8 V	97	106	145	160	483	532
1.5 V	77	85	115	127	383	422
1.2 V	57	63	85	94	283	312

(1) Calculated for V_{OL} = 0.35 V

(2) Assumes output driver V_{OL} = 0.175 V at stated current

(3) +10% to compensate for V_{DD} range and resistor tolerance

9.2.2.3 PCA9306 Bandwidth

The maximum frequency of the PCA9306 is dependent on the application. The device can operate at speeds of > 100MHz given the correct conditions. The maximum frequency is dependent upon the loading of the application. The PCA9306 behaves like a standard switch where the bandwidth of the device is dictated by the on resistance and on capacitance of the device.

Figure 9 shows a bandwidth measurement of the PCA9306 using a two-port network analyzer.

The 3-dB point of the PCA9306 is ≈600 MHz. However, this is an analog type of measurement. For digital applications the signal should not degrade up to the fifth harmonic of the digital signal. As a rule of thumb, the frequency bandwidth should be at least five times the maximum digital clock rate. This component of the signal is very important in determining the overall shape of the digital signal. In the case of the PCA9306, digital clock frequency of >100 MHz can be achieved.

The PCA9306 does not provide any drive capability like the PCA9515 or PCA9517 series of devices. Therefore higher frequency applications will require higher drive strength from the host side. No pull-up resistor is needed on the host side (3.3 V) if the PCA9306 is being driven by standard CMOS push-pull output driver. Ideally, it is best to minimize the trace length from the PCA9306 on the sink side (1.8 V) to minimize signal degradation.

You can then use a simple formula to compute the maximum "practical" frequency component. Or the "knee" frequency (f_{knee}). All fast edges have an infinite spectrum of frequency components. However, there is an inflection (or "knee") in the frequency spectrum of fast edges where frequency components higher than f_{knee} are insignificant in determining the shape of the signal.

To calculate f_{knee}:

$$f_{knee} = 0.5/RT \text{ (10–80\%)}$$

$$f_{knee} = 0.4/RT \text{ (20–80\%)}$$

For signals with rise time characteristics based on 10- to 90-percent thresholds, f_{knee} is equal to 0.5 divided by the rise time of the signal. For signals with rise time characteristics based on 20- to 80-percent thresholds, which is very common in many of today's device specifications, f_{knee} is equal to 0.4 divided by the rise time of the signal.

Some guidelines to follow that will help maximize the performance of the device:

- Keep trace length to a minimum by placing the PCA9306 close to the I²C output of the processor
- The trace length should be less than half the time of flight to reduce ringing and line reflections or non monotonic behavior in the switching region
- To reduce overshoots, a pull-up resistor can be added on the 1.8 V side; be aware that a slower fall time is to be expected

9.2.3 Application Curve

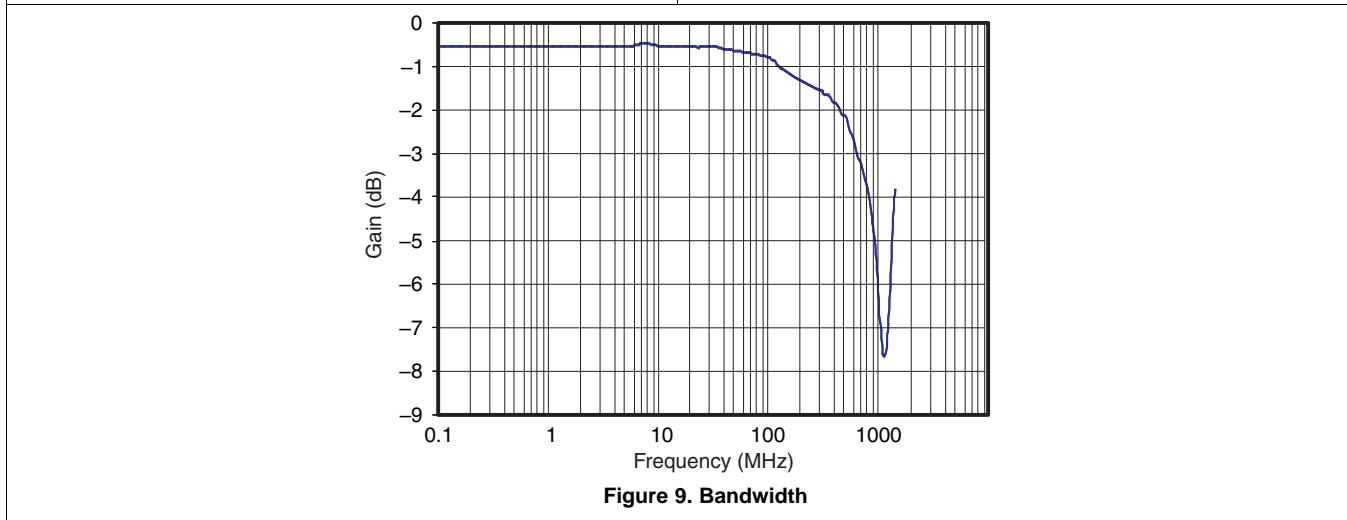
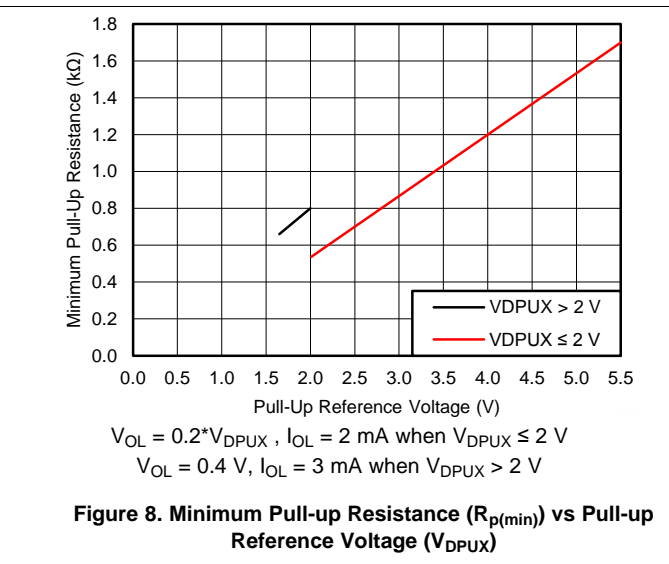
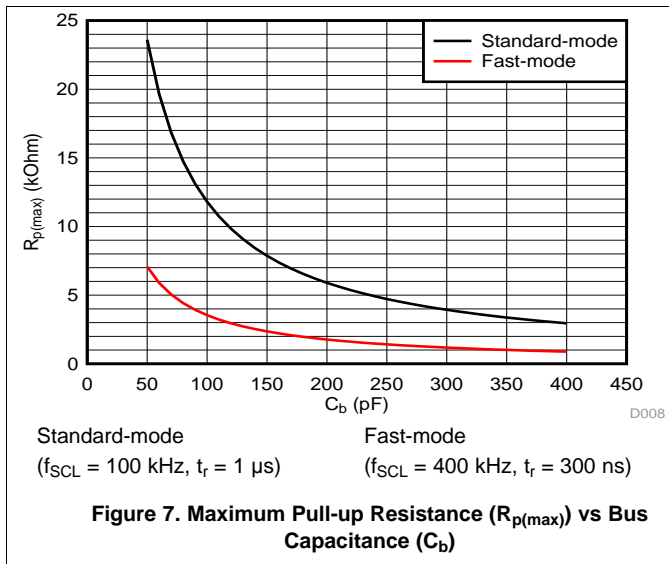

10 Power Supply Requirements

For supplying power to the PCA9306, the V_{REF1} pin can be connected directly to a power supply. The V_{REF2} pin must be connected to the V_{DPU} power supply through a 200-k Ω resistor. Failure to have a high impedance resistor between V_{REF2} and V_{DPU} will result in excessive current draw and unreliable device operation.

11 Layout

11.1 Layout Guidelines

For printed circuit board (PCB) layout of the PCA9306, common PCB layout practices should be followed but additional concerns related to high-speed data transfer such as matched impedances and differential pairs are not a concern for I²C signal speeds.

In all PCB layouts, it is a best practice to avoid right angles in signal traces, to fan out signal traces away from each other upon leaving the vicinity of an integrated circuit (IC), and to use thicker trace widths to carry higher amounts of current that commonly pass through power and ground traces. The 100-pF filter capacitor should be placed as close to V_{REF2} as possible. A larger de-coupling capacitor can also be used, but a longer time constant of two capacitors and the 200-k Ω resistor will result in longer turn on and turn off times for the PCA9306. These best practices are shown in [Figure 10](#).

For the layout example provided in [Figure 10](#), it would be possible to fabricate a PCB with only 2 layers by using the top layer for signal routing and the bottom layer as a split plane for power (V_{CC}) and ground (GND). However, a 4 layer board is preferable for boards with higher density signal routing. On a 4 layer PCB, it is common to route signals on the top and bottom layer, dedicate one internal layer to a ground plane, and dedicate the other internal layer to a power plane. In a board layout using planes or split planes for power and ground, vias are placed directly next to the surface mount component pad which needs to attach to V_{CC} or GND and the via is connected electrically to the internal layer or the other side of the board. Vias are also used when a signal trace needs to be routed to the opposite side of the board, but this technique is not demonstrated in [Figure 10](#).

11.2 Layout Example

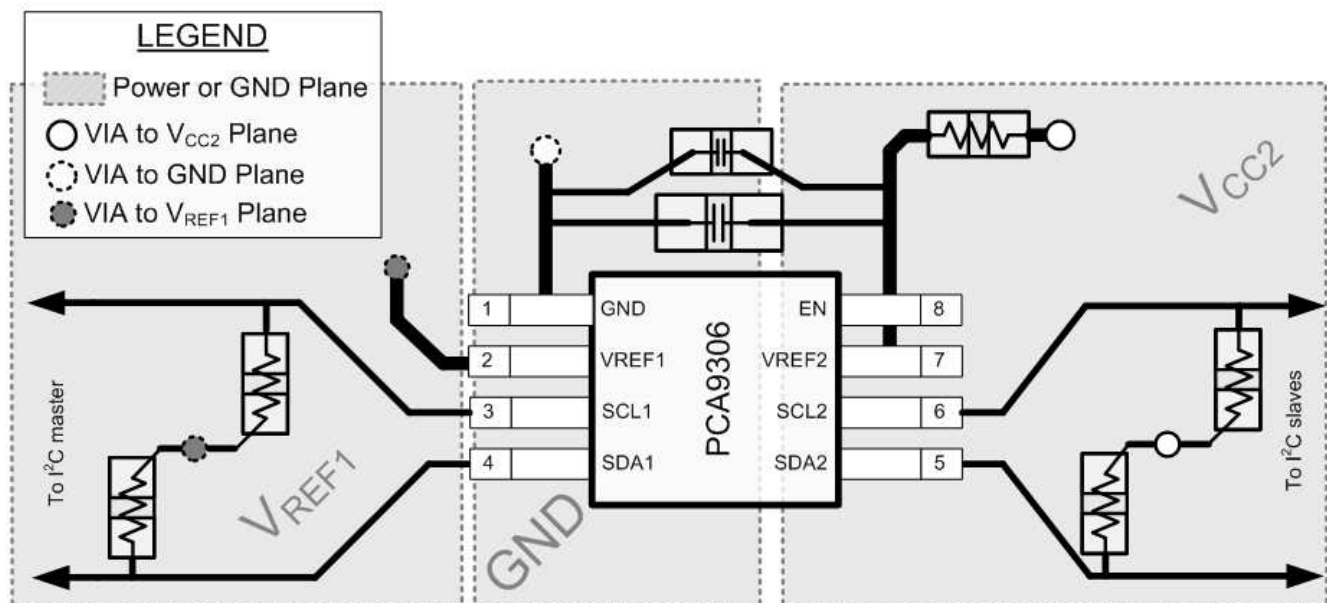

Figure 10. PCA9306 Layout Example

12 Device and Documentation Support

12.1 Trademarks

All trademarks are the property of their respective owners.

12.2 Electrostatic Discharge Caution



These devices have limited built-in ESD protection. The leads should be shorted together or the device placed in conductive foam during storage or handling to prevent electrostatic damage to the MOS gates.

12.3 Glossary

[SLYZ022](#) — *TI Glossary*.

This glossary lists and explains terms, acronyms, and definitions.

13 Mechanical, Packaging, and Orderable Information

The following pages include mechanical, packaging, and orderable information. This information is the most current data available for the designated devices. This data is subject to change without notice and revision of this document. For browser-based versions of this data sheet, refer to the left-hand navigation.

PACKAGING INFORMATION

Orderable Device	Status (1)	Package Type	Package Drawing	Pins	Package Qty	Eco Plan (2)	Lead/Ball Finish (6)	MSL Peak Temp (3)	Op Temp (°C)	Device Marking (4/5)	Samples
PCA9306DCTR	ACTIVE	SM8	DCT	8	3000	Green (RoHS & no Sb/Br)	CU NIPDAU	Level-1-260C-UNLIM	-40 to 85	7BD Y	Samples
PCA9306DCTRE4	ACTIVE	SM8	DCT	8	3000	Green (RoHS & no Sb/Br)	CU NIPDAU	Level-1-260C-UNLIM	-40 to 85	7BD Y	Samples
PCA9306DCTRG4	ACTIVE	SM8	DCT	8	3000	Green (RoHS & no Sb/Br)	CU NIPDAU	Level-1-260C-UNLIM	-40 to 85	7BD Y	Samples
PCA9306DCTT	ACTIVE	SM8	DCT	8	250	Green (RoHS & no Sb/Br)	CU NIPDAU	Level-1-260C-UNLIM	-40 to 85	7BD Y	Samples
PCA9306DCTTE4	ACTIVE	SM8	DCT	8	250	Green (RoHS & no Sb/Br)	CU NIPDAU	Level-1-260C-UNLIM	-40 to 85	7BD Y	Samples
PCA9306DCTTG4	ACTIVE	SM8	DCT	8	250	Green (RoHS & no Sb/Br)	CU NIPDAU	Level-1-260C-UNLIM	-40 to 85	7BD Y	Samples
PCA9306DCUR	ACTIVE	US8	DCU	8	3000	Green (RoHS & no Sb/Br)	CU NIPDAU CU SN	Level-1-260C-UNLIM	-40 to 85	(7BDP ~ 7BDS ~ BD) 7Y	Samples
PCA9306DCURE4	ACTIVE	US8	DCU	8	3000	Green (RoHS & no Sb/Br)	CU NIPDAU	Level-1-260C-UNLIM	-40 to 85	7BDS	Samples
PCA9306DCURG4	ACTIVE	US8	DCU	8	3000	Green (RoHS & no Sb/Br)	CU NIPDAU	Level-1-260C-UNLIM	-40 to 85	7BDS	Samples
PCA9306DCUT	ACTIVE	US8	DCU	8	250	Green (RoHS & no Sb/Br)	CU NIPDAU CU SN	Level-1-260C-UNLIM	-40 to 85	(7BDP ~ 7BDS ~ BD) 7Y	Samples
PCA9306DCUTE4	ACTIVE	US8	DCU	8	250	Green (RoHS & no Sb/Br)	CU NIPDAU	Level-1-260C-UNLIM	-40 to 85	7BDS	Samples
PCA9306DCUTG4	ACTIVE	US8	DCU	8	250	Green (RoHS & no Sb/Br)	CU NIPDAU	Level-1-260C-UNLIM	-40 to 85	7BDS	Samples
PCA9306DQER	ACTIVE	X2SON	DQE	8	5000	Green (RoHS & no Sb/Br)	CU NIPDAUAG	Level-1-260C-UNLIM	-40 to 85	7F	Samples
PCA9306YZTR	ACTIVE	DSBGA	YZT	8	3000	Green (RoHS & no Sb/Br)	SNAGCU	Level-1-260C-UNLIM	-40 to 85	7F	Samples

(1) The marketing status values are defined as follows:

ACTIVE: Product device recommended for new designs.

LIFEBUY: TI has announced that the device will be discontinued, and a lifetime-buy period is in effect.

NRND: Not recommended for new designs. Device is in production to support existing customers, but TI does not recommend using this part in a new design.

PREVIEW: Device has been announced but is not in production. Samples may or may not be available.

OBSOLETE: TI has discontinued the production of the device.

(2) Eco Plan - The planned eco-friendly classification: Pb-Free (RoHS), Pb-Free (RoHS Exempt), or Green (RoHS & no Sb/Br) - please check <http://www.ti.com/productcontent> for the latest availability information and additional product content details.

TBD: The Pb-Free/Green conversion plan has not been defined.

Pb-Free (RoHS): TI's terms "Lead-Free" or "Pb-Free" mean semiconductor products that are compatible with the current RoHS requirements for all 6 substances, including the requirement that lead not exceed 0.1% by weight in homogeneous materials. Where designed to be soldered at high temperatures, TI Pb-Free products are suitable for use in specified lead-free processes.

Pb-Free (RoHS Exempt): This component has a RoHS exemption for either 1) lead-based flip-chip solder bumps used between the die and package, or 2) lead-based die adhesive used between the die and leadframe. The component is otherwise considered Pb-Free (RoHS compatible) as defined above.

Green (RoHS & no Sb/Br): TI defines "Green" to mean Pb-Free (RoHS compatible), and free of Bromine (Br) and Antimony (Sb) based flame retardants (Br or Sb do not exceed 0.1% by weight in homogeneous material)

(3) MSL, Peak Temp. - The Moisture Sensitivity Level rating according to the JEDEC industry standard classifications, and peak solder temperature.

(4) There may be additional marking, which relates to the logo, the lot trace code information, or the environmental category on the device.

(5) Multiple Device Markings will be inside parentheses. Only one Device Marking contained in parentheses and separated by a "~" will appear on a device. If a line is indented then it is a continuation of the previous line and the two combined represent the entire Device Marking for that device.

(6) Lead/Ball Finish - Orderable Devices may have multiple material finish options. Finish options are separated by a vertical ruled line. Lead/Ball Finish values may wrap to two lines if the finish value exceeds the maximum column width.

Important Information and Disclaimer: The information provided on this page represents TI's knowledge and belief as of the date that it is provided. TI bases its knowledge and belief on information provided by third parties, and makes no representation or warranty as to the accuracy of such information. Efforts are underway to better integrate information from third parties. TI has taken and continues to take reasonable steps to provide representative and accurate information but may not have conducted destructive testing or chemical analysis on incoming materials and chemicals. TI and TI suppliers consider certain information to be proprietary, and thus CAS numbers and other limited information may not be available for release.

In no event shall TI's liability arising out of such information exceed the total purchase price of the TI part(s) at issue in this document sold by TI to Customer on an annual basis.

OTHER QUALIFIED VERSIONS OF PCA9306 :

- Automotive: [PCA9306-Q1](#)

NOTE: Qualified Version Definitions:

- Automotive - Q100 devices qualified for high-reliability automotive applications targeting zero defects

TAPE AND REEL INFORMATION

QUADRANT ASSIGNMENTS FOR PIN 1 ORIENTATION IN TAPE

*All dimensions are nominal

Device	Package Type	Package Drawing	Pins	SPQ	Reel Diameter (mm)	Reel Width W1 (mm)	A0 (mm)	B0 (mm)	K0 (mm)	P1 (mm)	W (mm)	Pin1 Quadrant
PCA9306DCUR	US8	DCU	8	3000	180.0	9.0	2.05	3.3	1.0	4.0	8.0	Q3
PCA9306DCUR	US8	DCU	8	3000	180.0	8.4	2.25	3.35	1.05	4.0	8.0	Q3
PCA9306DCURG4	US8	DCU	8	3000	180.0	8.4	2.25	3.35	1.05	4.0	8.0	Q3
PCA9306DCUTG4	US8	DCU	8	250	180.0	8.4	2.25	3.35	1.05	4.0	8.0	Q3
PCA9306DQER	X2SON	DQE	8	5000	180.0	8.4	1.2	1.6	0.55	4.0	8.0	Q1
PCA9306YZTR	DSBGA	YZT	8	3000	180.0	8.4	1.02	2.02	0.75	4.0	8.0	Q1

TAPE AND REEL BOX DIMENSIONS

*All dimensions are nominal

Device	Package Type	Package Drawing	Pins	SPQ	Length (mm)	Width (mm)	Height (mm)
PCA9306DCUR	US8	DCU	8	3000	182.0	182.0	20.0
PCA9306DCUR	US8	DCU	8	3000	202.0	201.0	28.0
PCA9306DCURG4	US8	DCU	8	3000	202.0	201.0	28.0
PCA9306DCUTG4	US8	DCU	8	250	202.0	201.0	28.0
PCA9306DQER	X2SON	DQE	8	5000	202.0	201.0	28.0
PCA9306YZTR	DSBGA	YZT	8	3000	182.0	182.0	17.0

DCT (R-PDSO-G8)

PLASTIC SMALL OUTLINE

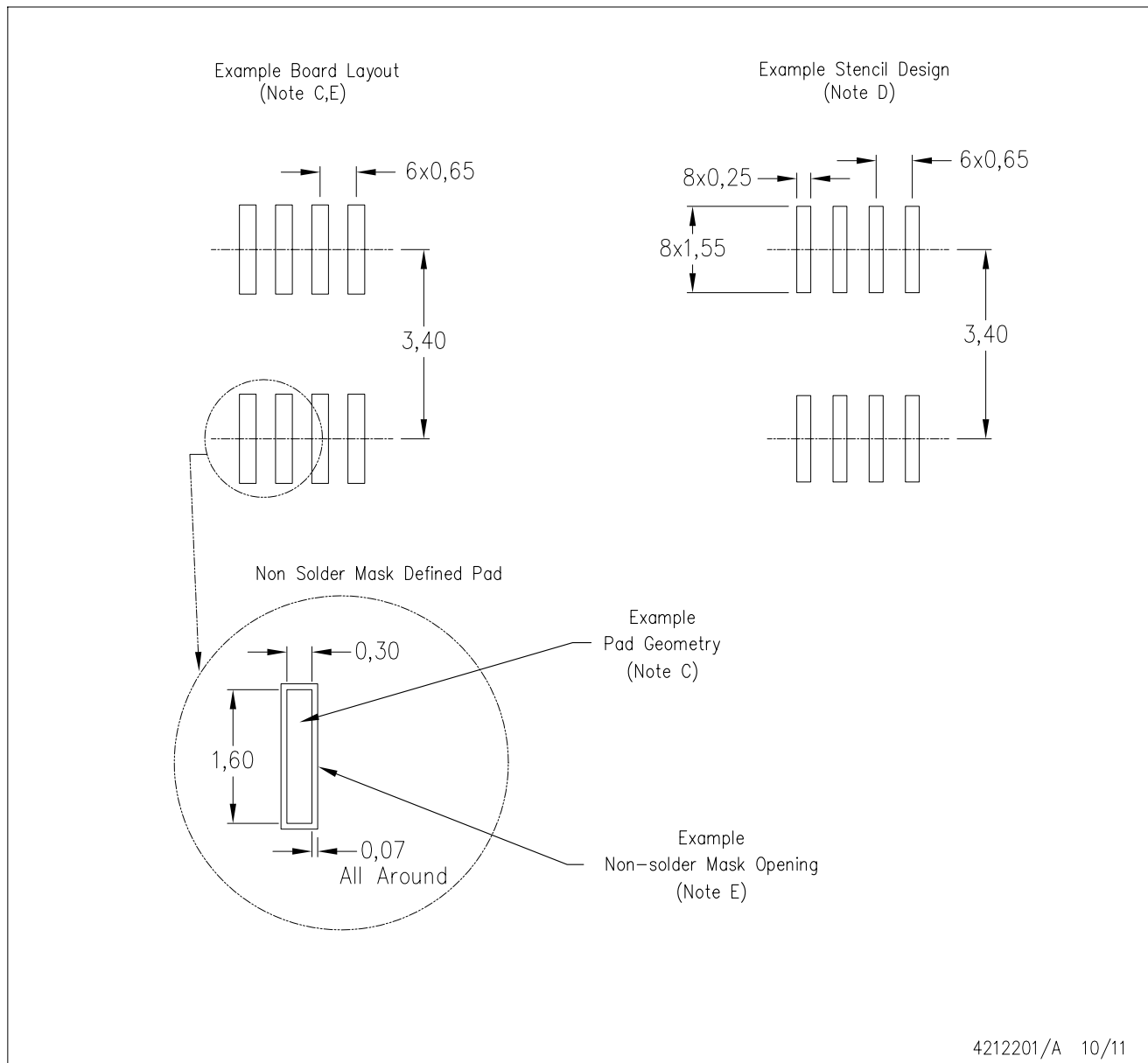

- NOTES:
- A. All linear dimensions are in millimeters.
 - B. This drawing is subject to change without notice.
 - C. Publication IPC-7351 is recommended for alternate designs.
 - D. Laser cutting apertures with trapezoidal walls and also rounding corners will offer better paste release. Customers should contact their board assembly site for stencil design recommendations. Refer to IPC-7525.
 - E. Customers should contact their board fabrication site for solder mask tolerances between and around signal pads.

DCU (S-PDSO-G8)

PLASTIC SMALL OUTLINE PACKAGE (DIE DOWN)

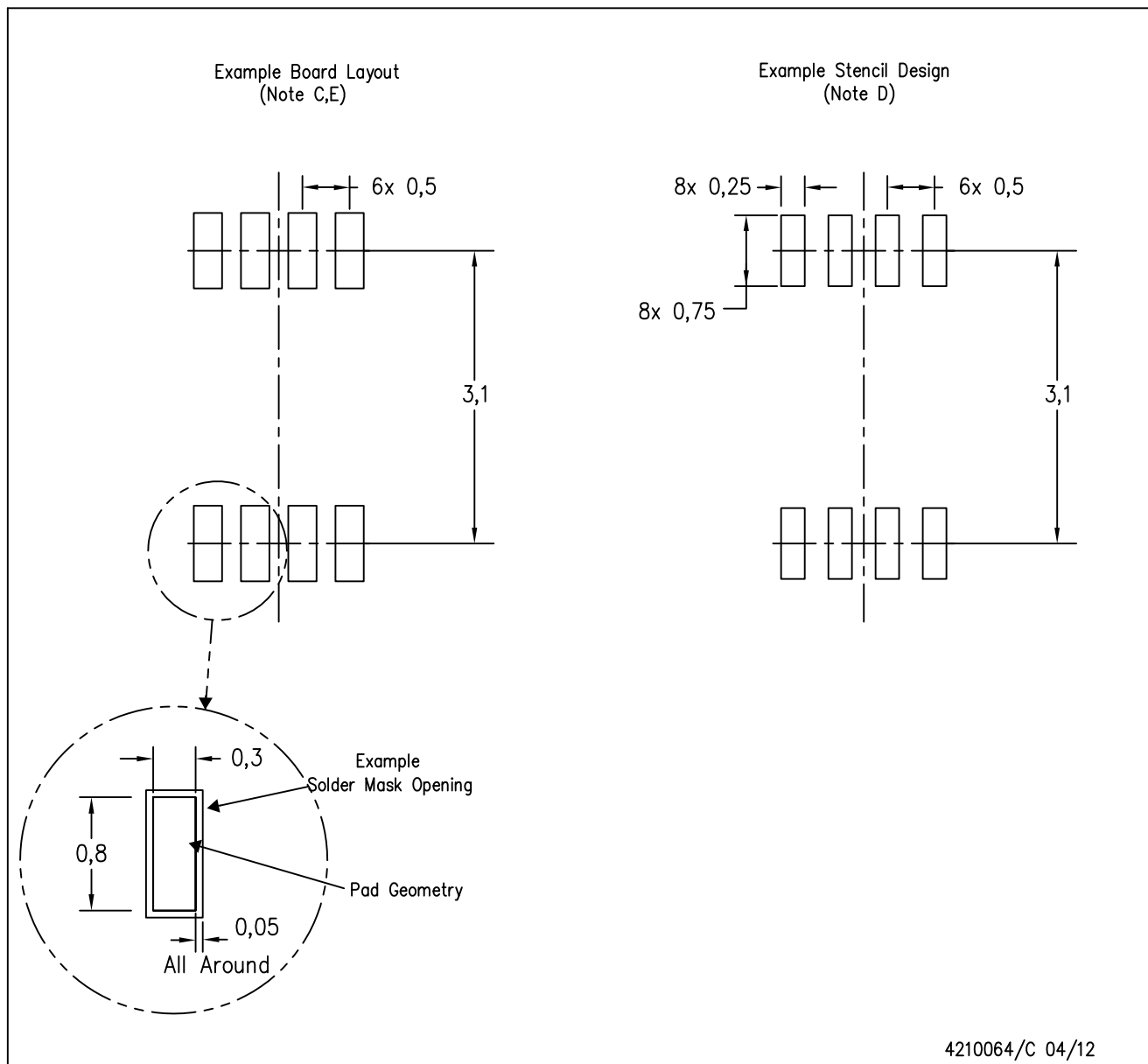

- NOTES:
- A. All linear dimensions are in millimeters.
 - B. This drawing is subject to change without notice.
 - C. Publication IPC-7351 is recommended for alternate designs.
 - D. Laser cutting apertures with trapezoidal walls and also rounding corners will offer better paste release. Customers should contact their board assembly site for stencil design recommendations. Refer to IPC-7525 for other stencil recommendations.
 - E. Customers should contact their board fabrication site for solder mask tolerances between and around signal pads.

DQE (R-PX2SON-N8)

PLASTIC SMALL OUTLINE NO-LEAD

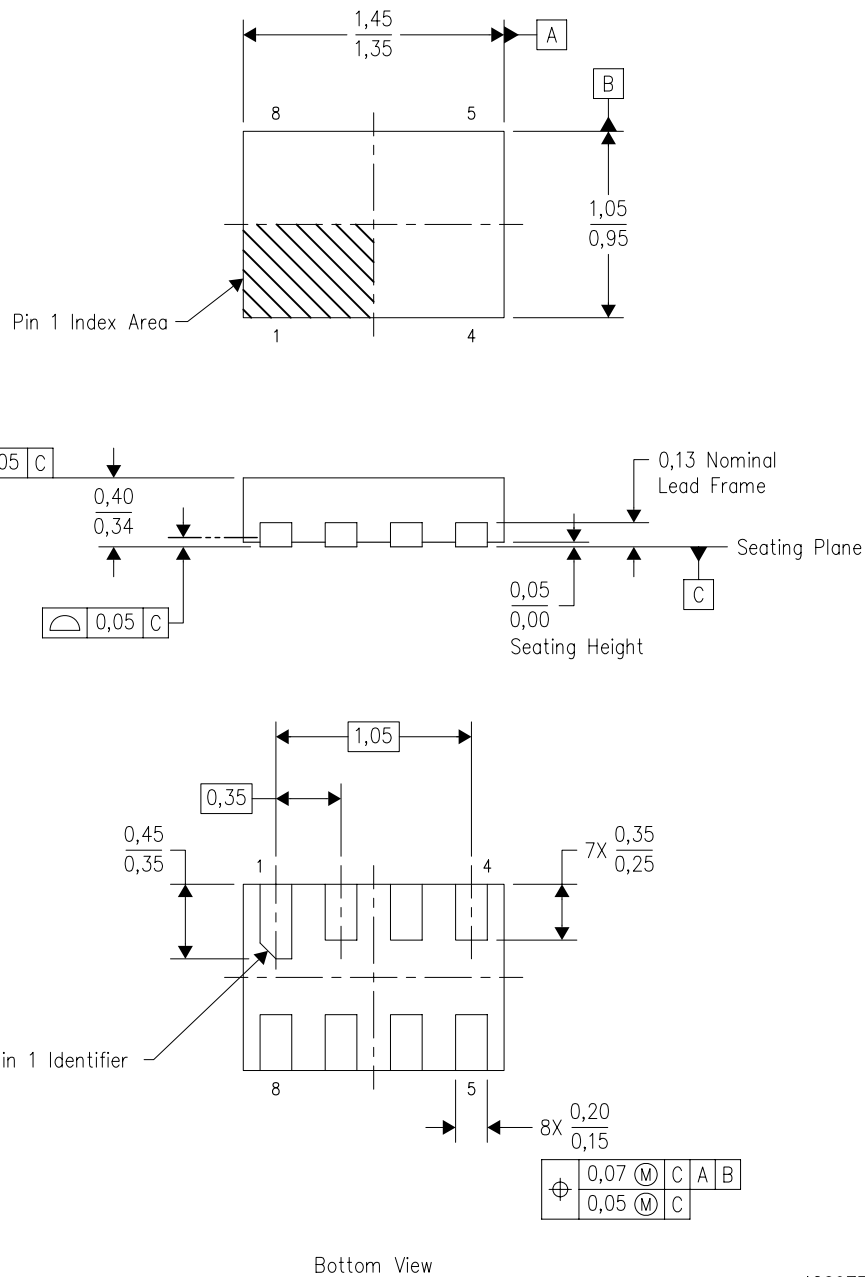

4209779/B 10/2008

- NOTES:
- A. All linear dimensions are in millimeters. Dimensioning and tolerancing per ASME Y14.5M-1994.
 - B. This drawing is subject to change without notice.
 - C. SON (Small Outline No-Lead) package configuration.
 - D. This package complies to JEDEC MO-287 variation X2EAF.

DQE (R-PX2SON-N8)

PLASTIC SMALL OUTLINE NO-LEAD

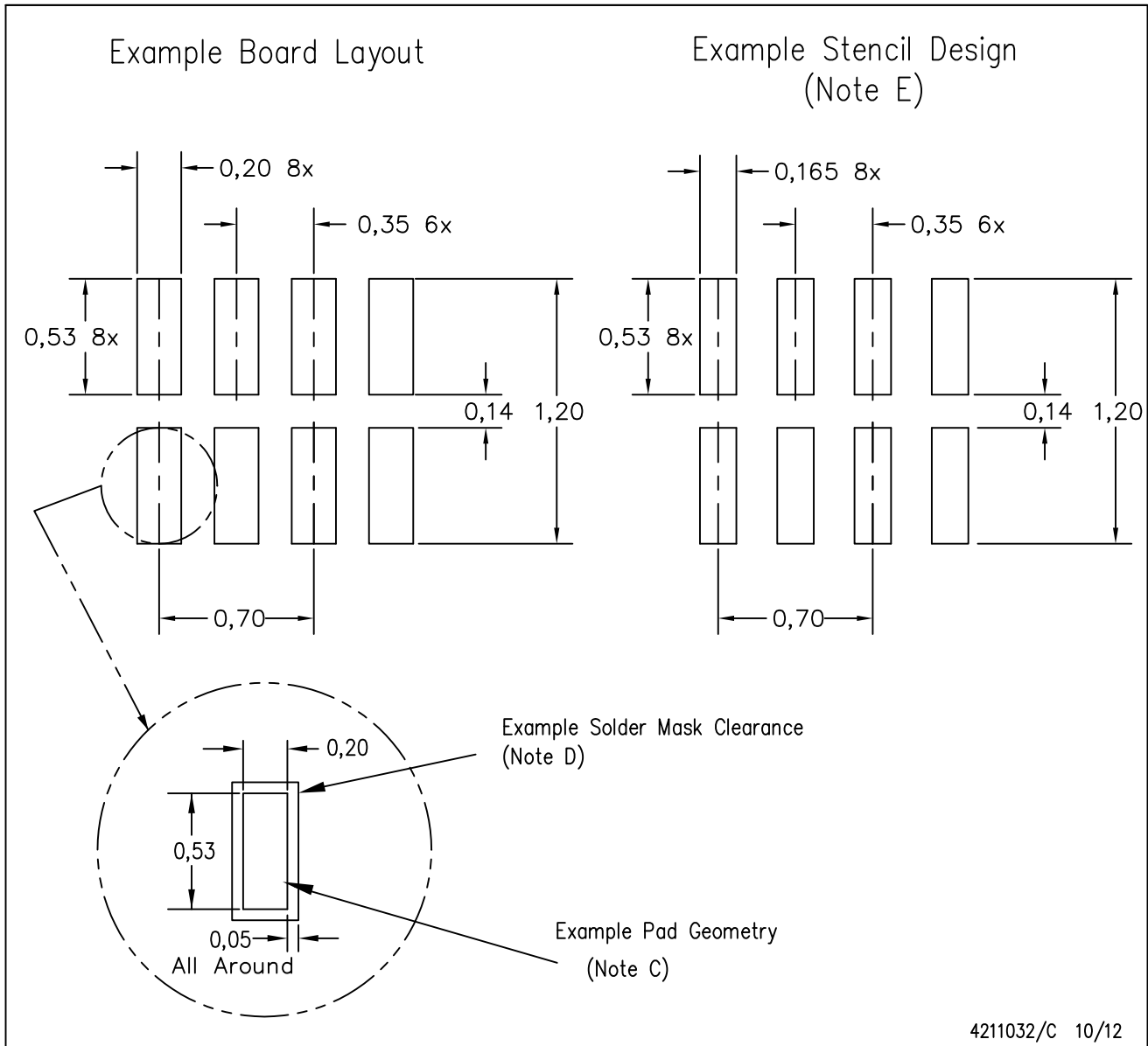

- NOTES:
- A. All linear dimensions are in millimeters.
 - B. This drawing is subject to change without notice.
 - C. Publication IPC-7351 is recommended for alternate designs.
 - D. Customers should contact their board fabrication site for minimum solder mask web tolerances between signal pads.
If 2 mil solder mask is outside PCB vendor capability, it is advised to omit solder mask.
 - E. Maximum stencil thickness 0,1016 mm (4 mils). All linear dimensions are in millimeters.
 - F. Laser cutting apertures with trapezoidal walls and also rounding corners will offer better paste release. Customers should contact their board assembly site for stencil design recommendations. Refer to IPC 7525 for stencil design considerations.
 - G. Over-printing land for acceptable area ratio is not viable due to land width and bridging potential. Customer may further reduce side aperture dimensions if stencil manufacturing process allows for sufficient release at smaller opening.
 - H. Suggest stencils cut with lasers such as Fiber Laser that produce the greatest positional accuracy.
 - I. Component placement force should be minimized to prevent excessive paste block deformation.

MECHANICAL DATA

YZT (R-XBGA-N8)

DIE-SIZE BALL GRID ARRAY

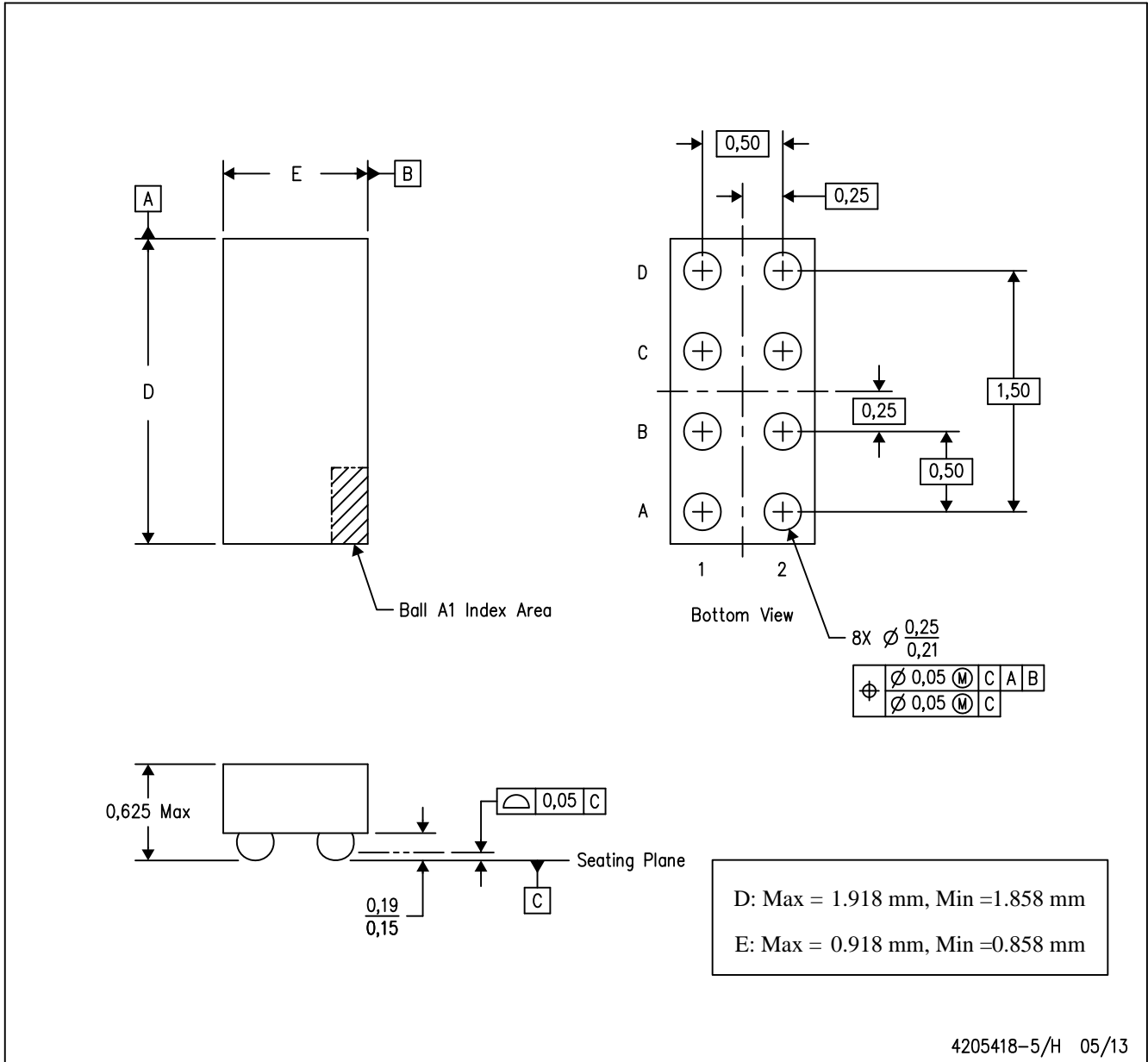

- NOTES:
- A. All linear dimensions are in millimeters. Dimensioning and tolerancing per ASME Y14.5M-1994.
 - B. This drawing is subject to change without notice.
 - C. NanoFree™ package configuration.

NanoFree is a trademark of Texas Instruments.

IMPORTANT NOTICE

Texas Instruments Incorporated and its subsidiaries (TI) reserve the right to make corrections, enhancements, improvements and other changes to its semiconductor products and services per JESD46, latest issue, and to discontinue any product or service per JESD48, latest issue. Buyers should obtain the latest relevant information before placing orders and should verify that such information is current and complete. All semiconductor products (also referred to herein as "components") are sold subject to TI's terms and conditions of sale supplied at the time of order acknowledgment.

TI warrants performance of its components to the specifications applicable at the time of sale, in accordance with the warranty in TI's terms and conditions of sale of semiconductor products. Testing and other quality control techniques are used to the extent TI deems necessary to support this warranty. Except where mandated by applicable law, testing of all parameters of each component is not necessarily performed.

TI assumes no liability for applications assistance or the design of Buyers' products. Buyers are responsible for their products and applications using TI components. To minimize the risks associated with Buyers' products and applications, Buyers should provide adequate design and operating safeguards.

TI does not warrant or represent that any license, either express or implied, is granted under any patent right, copyright, mask work right, or other intellectual property right relating to any combination, machine, or process in which TI components or services are used. Information published by TI regarding third-party products or services does not constitute a license to use such products or services or a warranty or endorsement thereof. Use of such information may require a license from a third party under the patents or other intellectual property of the third party, or a license from TI under the patents or other intellectual property of TI.

Reproduction of significant portions of TI information in TI data books or data sheets is permissible only if reproduction is without alteration and is accompanied by all associated warranties, conditions, limitations, and notices. TI is not responsible or liable for such altered documentation. Information of third parties may be subject to additional restrictions.

Resale of TI components or services with statements different from or beyond the parameters stated by TI for that component or service voids all express and any implied warranties for the associated TI component or service and is an unfair and deceptive business practice. TI is not responsible or liable for any such statements.

Buyer acknowledges and agrees that it is solely responsible for compliance with all legal, regulatory and safety-related requirements concerning its products, and any use of TI components in its applications, notwithstanding any applications-related information or support that may be provided by TI. Buyer represents and agrees that it has all the necessary expertise to create and implement safeguards which anticipate dangerous consequences of failures, monitor failures and their consequences, lessen the likelihood of failures that might cause harm and take appropriate remedial actions. Buyer will fully indemnify TI and its representatives against any damages arising out of the use of any TI components in safety-critical applications.

In some cases, TI components may be promoted specifically to facilitate safety-related applications. With such components, TI's goal is to help enable customers to design and create their own end-product solutions that meet applicable functional safety standards and requirements. Nonetheless, such components are subject to these terms.

No TI components are authorized for use in FDA Class III (or similar life-critical medical equipment) unless authorized officers of the parties have executed a special agreement specifically governing such use.

Only those TI components which TI has specifically designated as military grade or "enhanced plastic" are designed and intended for use in military/aerospace applications or environments. Buyer acknowledges and agrees that any military or aerospace use of TI components which have **not** been so designated is solely at the Buyer's risk, and that Buyer is solely responsible for compliance with all legal and regulatory requirements in connection with such use.

TI has specifically designated certain components as meeting ISO/TS16949 requirements, mainly for automotive use. In any case of use of non-designated products, TI will not be responsible for any failure to meet ISO/TS16949.

Products

Audio	www.ti.com/audio
Amplifiers	amplifier.ti.com
Data Converters	dataconverter.ti.com
DLP® Products	www.dlp.com
DSP	dsp.ti.com
Clocks and Timers	www.ti.com/clocks
Interface	interface.ti.com
Logic	logic.ti.com
Power Mgmt	power.ti.com
Microcontrollers	microcontroller.ti.com
RFID	www.ti-rfid.com
OMAP Applications Processors	www.ti.com/omap
Wireless Connectivity	www.ti.com/wirelessconnectivity

Applications

Automotive and Transportation	www.ti.com/automotive
Communications and Telecom	www.ti.com/communications
Computers and Peripherals	www.ti.com/computers
Consumer Electronics	www.ti.com/consumer-apps
Energy and Lighting	www.ti.com/energy
Industrial	www.ti.com/industrial
Medical	www.ti.com/medical
Security	www.ti.com/security
Space, Avionics and Defense	www.ti.com/space-avionics-defense
Video and Imaging	www.ti.com/video

TI E2E Community

e2e.ti.com

Mouser Electronics

Authorized Distributor

Click to View Pricing, Inventory, Delivery & Lifecycle Information:

Texas Instruments:

[PCA9306DCURG4](#) [PCA9306DCUTG4](#) [PCA9306DCTR](#) [PCA9306DCTRE4](#) [PCA9306DCTT](#) [PCA9306DCTTE4](#)
[PCA9306DCUR](#) [PCA9306DCURE4](#) [PCA9306DCUT](#) [PCA9306DCUTE4](#) [PCA9306DCTRG4](#) [PCA9306DCTTG4](#)
[PCA9306DQER](#) [PCA9306YZTR](#)