

- ESX series capacitors are low length (max 25mm height) with low impedance for high frequency.
- Load life 105°C, 5000 hours assured. (2000 hours for  $D \leq 8\text{mm}$ )

## Characteristics

<b>Voltage Range</b>	6.3 ~ 63V							
<b>Capacitance Range</b>	0.47 ~ 4700uF							
<b>Temperature Range</b>	-55 ~ + 105°C							
<b>Leakage Current</b>	I=0.01CV or 3uA, whichever is greater (After 2 minutes)							
<b>Capacitance Tolerance</b>	±20% at 120Hz, 20°C (10% Tol. is available upon request)							
<b>Dissipation Factor</b>	WV	6.3	10	16	25	35	50	63
	tanδ	0.15	0.12	0.11	0.09	0.08	0.06	0.05
For capacitance > 1000uF, add 0.02 for every 1000uF. (at 20°C, 120Hz)								
<b>Load life after application of the rated voltage with ripple current for 5000 hrs at 105°C (2000 hrs for <math>D \leq 8\text{mm}</math>)</b>	Leakage current				Less than initial specified value			
	Capacitance change				Within ±20% of initial value			
	tanδ				200% or less of initial specified value			
<b>Shelf life (at 105°C)</b>	After 1000 hrs no load test the leakage current, capacitance and tanδ same as load life value.							

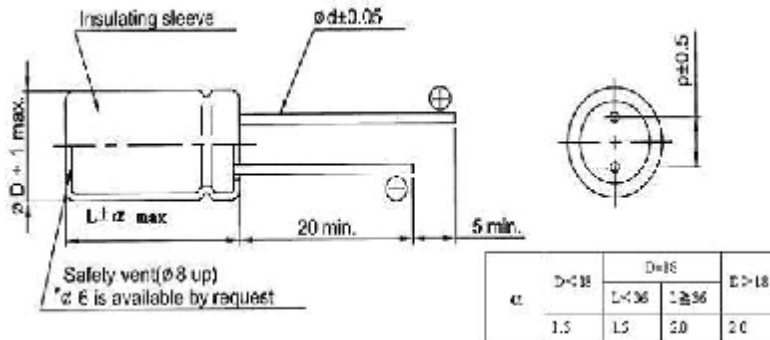

## Drawing

Df	5	6.3	8	10	13	16	18
p	2.0	2.5	3.5	5.0	5.0	7.5	7.5
df	0.5	0.5	0.5	0.6	0.6	0.8	0.8

## Multiplier for R.C. vs Temperature

Temp.(°C)	45	60	70	85	95	105
Multiplier	2.10	1.90	1.65	1.40	1.25	1.00

## Ripple Current Coefficients

Frequency (Hz)	60	120	400	1K	10K	50K - 100K
Cap.(uF) / Hz	Multiplier					
Cap. ≤ 10	0.47	0.59	0.76	0.85	0.97	1
10 < Cap. ≤ 100	0.52	0.62	0.80	0.89	0.97	1
100 < Cap. ≤ 1000	0.58	0.72	0.84	0.90	0.98	1
1000 < Cap.	0.63	0.78	0.87	0.91	0.98	1

**Dimensions, Maximum Permissible Ripple Current & Impedance**

uF	WV	6.3			10			16			25		
		DφxL(mm)	Impedance (Ω)max 20°C 100KHz	Ripple Current mA(rms)	DφxL(mm)	Impedance (Ω)max 20°C 100KHz	Ripple Current mA (rms)	DφxL(mm)	Impedance (Ω)max 20°C 100KHz	Ripple Current mA(rms)	DφxL(mm)	Impedance (Ω)max 20°C 100KHz	Ripple Current mA(rms)
				105°C 100KHz			105°C 100KHz			105°C 100KHz			105°C 100KHz
10							5x11	4.00	37	5x11	2.10	56	
22							5x11	2.00	70	5x11	1.80	120	
33							5x11	1.26	130	5x11	1.20	150	
47				5x11	1.20	120	5x11	0.52	190	5x11	0.50	220	
100		5x11	0.95	185	5x11	0.48	205	6.3x11	0.31	260	6.3x11	0.28	300
220		6.3x11	0.60	300	6.3x11	0.28	330	8x12	0.21	455	8x12	0.125	550
330		8x12	0.30	390	8x12	0.16	430	8x12	0.12	550	10x13	0.082	720
470		8x12	0.22	415	8x12	0.12	555	10x13	0.095	722	10x16	0.065	1040
1000		10x13	0.12	625	10x16	0.07	1010	10x25	0.050	1180	13x25	0.039	1530
2200		13x20	0.06	1300	13x25	0.04	1690	13x25	0.033	1950	16x25	0.027	2405
3300		13x25	0.048	1425	16x25	0.029	1980	16x25	0.028	2340	18x25	0.022	2960
4700		16x25	0.032	1800	16x25	0.029	2100	16x31.5	0.024	2570	18x36	0.021	3600

uF	WV	35			50			63		
		DφxL(mm)	Impedance (Ω)max 20°C 100KHz	Ripple Current mA(rms)	DφxL(mm)	Impedance (Ω)max 20°C 100KHz	Ripple Current mA(rms)	DφxL(mm)	Impedance (Ω)max 20°C 100KHz	Ripple Current mA(rms)
				105°C 100KHz			105°C 100KHz			105°C 100KHz
1					5x11	3.95	25	5x11	2.80	27
2.2					5x11	2.60	33	5x11	2.40	38
3.3					5x11	2.00	45	5x11	2.00	48
4.7					5x11	1.89	58	5x11	1.89	62
10		5x11	1.90	70	5x11	1.70	100	5x11	1.65	105
22		5x11	1.36	130	6.3x11	1.00	135	6.3x11	0.80	170
33		5x11	0.95	175	6.3x11	0.74	230	8x12	0.61	245
47		6.3x11	0.44	250	8x12	0.50	285	8x12	0.56	290
100		8x12	0.19	380	10x13	0.18	475	10x16	0.24	590
220		10x13	0.098	720	10x20	0.085	900	13x20	0.080	1054
330		10x16	0.065	995	10x25	0.068	1050	13x25	0.067	1160
470		10x20	0.050	1150	13x21	0.048	1490	16x25	0.041	1750
1000		16x25	0.036	1950	16x31.5	0.030	2130	16x36	0.030	1980
2200		16x31.5	0.022	2570						