



General Description

The C328-EV232 EV board is a simple application reference for the C328 Camera Module. It is built with RS232 transceivers to connect the C328 Module to a PC. An user friendly PC driver is provided for user to evaluate the key functions of the C328 camera module.

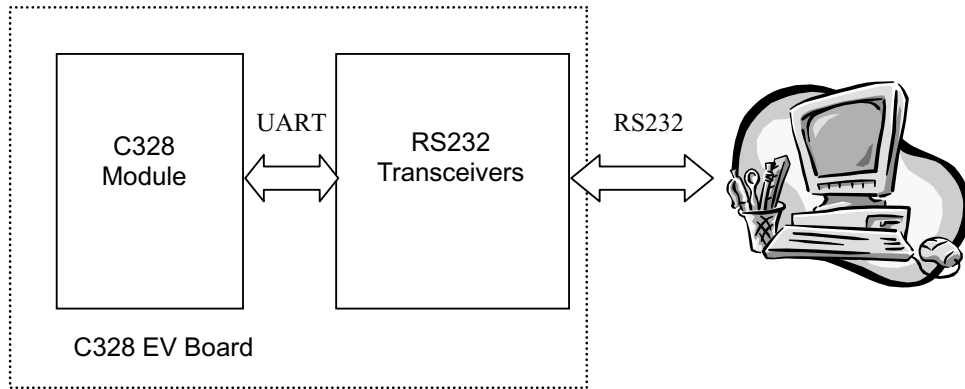

Figure 1 – System block diagram

Board Layout

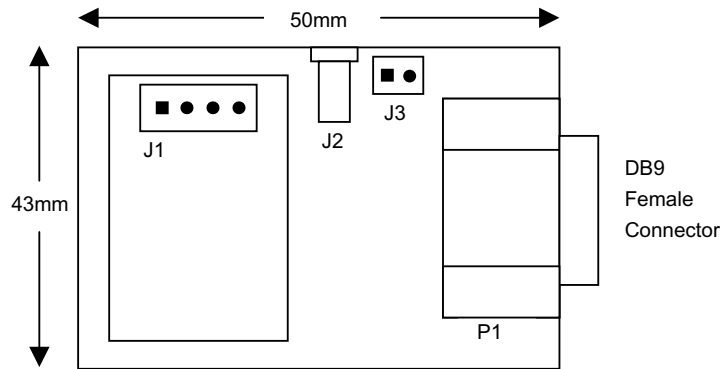

Figure 2 – C328 EV board layout

Connector Description:

J1	4 pin header 2mm pitch	To interface C328 module
J2	DC Power Jack, 5VDC input	For AD/DC adapter
J3	DC input, 3.6V or 4.5V	For power supply or battery
P1	9pin D type, female	For RS232 cable connect to PC

Installation of Software Driver

OS Support: Win98/ME/XP and COM1 is free

1. create a directory on the PC, eg c:\C328
2. copy the files to that directory. They include:
C328Ap.exe
c328Drv.dll
JPEGDecoder.dll



Procedures

1. Plug the C328 module into **J1** of the EV board
2. Connect the EV board to a PC using the RS232 cable included
3. Apply power to EV board through **J2** or **J3**
4. Run “**C328Ap.exe**”

Software Overview

After initialization, the appearance of the user interface will look like Figure 3.

Image will be displaying in the **Preview Window**. The **Progress Bar** shows the progress of the loading operation of the image.



Figure 3 – User Interface of C328-EV232

1. SnapShot Group

User can select the required resolution and then click “Go!” to get a picture.

The picture will be shown in the **SnapShot Picture View Window** and stored as “**snapshot.jpg**” in the same directory where “**C328Ap.exe**” is located. If you want to keep the image, you need to rename the file name, otherwise, it will be replaced by the new captured image.

2. View Group

This Group contains three buttons, **Begin**, **Set** and **Stop**. User can pause and resume to preview the live image by pressing the button **Stop** and **Begin** respectively.

When the button **Set** is pressed, a dialog containing the data parameter will be shown as Figure 4. User can change the image size accordingly in the dialog box. Click **Apply** to confirm the setting.

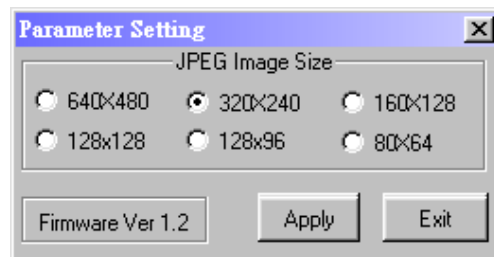

Fig 4- Parameter setting



ITM-EVA-328 Manual

