

## SN6501 Transformer Driver for Isolated Power Supplies

### 1 Features

- Push-Pull Driver for Small Transformers
- Single 3.3-V or 5-V Supply
- High Primary-side Current Drive:
  - 5-V Supply: 350 mA (Max)
  - 3.3-V Supply: 150 mA (Max)
- Low Ripple on Rectified Output Permits Small Output Capacitors
- Small 5-Pin SOT-23 Package

### 2 Applications

- Isolated Interface Power Supply for CAN, RS-485, RS-422, RS-232, SPI, I2C, Low-Power LAN
- Industrial Automation
- Process Control
- Medical Equipment

### 3 Description

The SN6501 is a monolithic oscillator/power-driver, specifically designed for small form factor, isolated power supplies in isolated interface applications. The device drives a low-profile, center-tapped transformer primary from a 3.3-V or 5-V DC power supply. The secondary can be wound to provide any isolated voltage based on transformer turns ratio.

The SN6501 consists of an oscillator followed by a gate drive circuit that provides the complementary output signals to drive the ground referenced N-channel power switches. The internal logic ensures break-before-make action between the two switches.

The SN6501 is available in a small SOT-23 (5) package, and is specified for operation at temperatures from  $-40^{\circ}\text{C}$  to  $125^{\circ}\text{C}$ .

#### Device Information<sup>(1)</sup>

PART NUMBER	PACKAGE	BODY SIZE (NOM)
SN6501	SOT-23 (5)	2.90 mm x 1.60 mm

(1) For all available packages, see the orderable addendum at the end of the datasheet.

#### Simplified Schematic

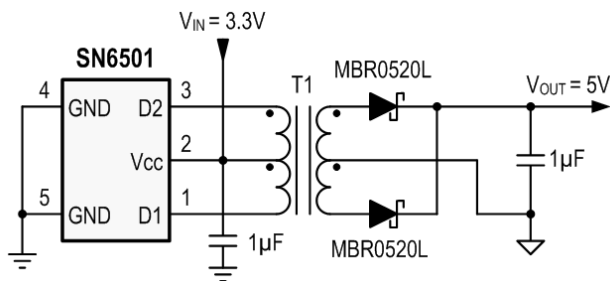

#### Output Voltage and Efficiency vs Output Current

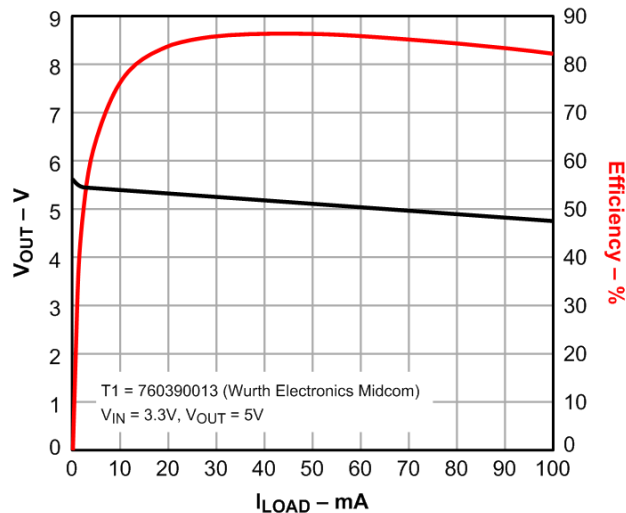

## Table of Contents

<b>1 Features</b> .....	<b>1</b>	8.2 Functional Block Diagram .....	<b>12</b>
<b>2 Applications</b> .....	<b>1</b>	8.3 Feature Description .....	<b>13</b>
<b>3 Description</b> .....	<b>1</b>	8.4 Device Functional Modes .....	<b>14</b>
<b>4 Revision History</b> .....	<b>2</b>	<b>9 Application and Implementation</b> .....	<b>15</b>
<b>5 Pin Configuration and Functions</b> .....	<b>4</b>	9.1 Application Information .....	<b>15</b>
<b>6 Specifications</b> .....	<b>4</b>	9.2 Typical Application .....	<b>16</b>
6.1 Absolute Maximum Ratings .....	<b>4</b>	<b>10 Power Supply Recommendations</b> .....	<b>26</b>
6.2 Handling Ratings .....	<b>4</b>	<b>11 Layout</b> .....	<b>26</b>
6.3 Recommended Operating Conditions .....	<b>5</b>	11.1 Layout Guidelines .....	<b>26</b>
6.4 Thermal Information .....	<b>5</b>	11.2 Layout Example .....	<b>26</b>
6.5 Electrical Characteristics .....	<b>5</b>	<b>12 Device and Documentation Support</b> .....	<b>27</b>
6.6 Switching Characteristics .....	<b>5</b>	12.1 Device Support .....	<b>27</b>
6.7 Typical Characteristics .....	<b>6</b>	12.2 Trademarks .....	<b>27</b>
<b>7 Parameter Measurement Information</b> .....	<b>12</b>	12.3 Electrostatic Discharge Caution .....	<b>27</b>
<b>8 Detailed Description</b> .....	<b>12</b>	12.4 Glossary .....	<b>27</b>
8.1 Overview .....	<b>12</b>	<b>13 Mechanical, Packaging, and Orderable Information</b> .....	<b>27</b>

## 4 Revision History

NOTE: Page numbers for previous revisions may differ from page numbers in the current version.

### Changes from Revision F (August 2013) to Revision G

Page

<ul style="list-style-type: none"> <li>Added <i>Pin Configuration and Functions</i> section, <i>Handling Rating</i> table, <i>Feature Description</i> section, <i>Device Functional Modes</i>, <i>Application and Implementation</i> section, <i>Power Supply Recommendations</i> section, <i>Layout</i> section, <i>Device and Documentation Support</i> section, and <i>Mechanical, Packaging, and Orderable Information</i> section .....</li> </ul>	<b>1</b>
---	----------

### Changes from Revision E (January 2013) to Revision F

Page

<ul style="list-style-type: none"> <li>Added <a href="#">Figure 13</a> and <a href="#">Figure 14</a> .....</li> <li>Added <a href="#">Figure 17</a> through <a href="#">Figure 18</a> .....</li> <li>Added <a href="#">Figure 23</a> through <a href="#">Figure 24</a> .....</li> <li>Changed <a href="#">Table 3</a> - Recommended Isolation Transformers Optimized for SN6501 .....</li> </ul>	<b>7</b> <b>7</b> <b>8</b> <b>20</b>
--	---

### Changes from Revision D (September 2012) to Revision E

Page

<ul style="list-style-type: none"> <li>Changed <a href="#">Figure 23</a> .....</li> </ul>	<b>8</b>
---	----------

### Changes from Revision C (March 2012) to Revision D

Page

<ul style="list-style-type: none"> <li>Changed <math>f_{OSC}</math>, Oscillator frequency To: <math>f_{SW}</math>, D1, D2 Switching frequency .....</li> <li>Added graphs <a href="#">Figure 3</a> through <a href="#">Figure 4</a> .....</li> <li>Changed the title of <a href="#">Figure 30</a> From: D1, D2 Oscillator Frequency vs Free-Air Temperature To: D1, D2 Switching Frequency vs Free-Air Temperature .....</li> <li>Added section: Recommended Transformers .....</li> <li>Changed the location and title of <a href="#">Figure 45</a> .....</li> </ul>	<b>5</b> <b>6</b> <b>9</b> <b>19</b> <b>19</b>
---	--

**Changes from Revision B (March 2012) to Revision C** **Page**

---

- Changed the  $f_{OSC}$  Oscillator frequency values ..... 5
  - Changed [Equation 4](#) ..... 18
- 

**Changes from Revision A (March 2012) to Revision B** **Page**

---

- Changed Feature From: Small 5-pin DBV Package To: Small 5-pin SOT23 Package..... 1
  - Changed [Figure 45](#) title ..... 19
- 

**Changes from Original (February 2012) to Revision A** **Page**

---

- Changed the device From: Product Preview To: Production ..... 1
  - Changed [Equation 10](#) ..... 19
  - Changed [Equation 11](#) ..... 19
  - Changed [Table 4](#), From: Wuerth-Elektronik / Midcom To: Wurth Electronics Midcom Inc ..... 21
  - Changed [Figure 54](#) ..... 24
-

## 5 Pin Configuration and Functions

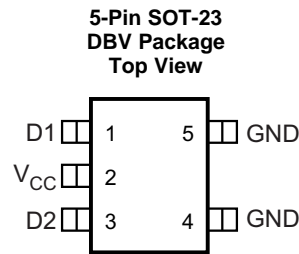

### Pin Functions

PIN			DESCRIPTION
NAME	NUMBER	TYPE	
D1	1	OD	Open Drain output 1. Connect this pin to one end of the transformer primary side.
V <sub>CC</sub>	2	P	Supply voltage input. Connect this pin to the center-tap of the transformer primary side. Buffer this voltage with a 1 $\mu$ F to 10 $\mu$ F ceramic capacitor.
D2	3	OD	Open Drain output 2. Connect this pin to the other end of the transformer primary side.
GND	4,5	P	Device ground. Connect this pin to board ground.

## 6 Specifications

### 6.1 Absolute Maximum Ratings

over operating free-air temperature range (unless otherwise noted)<sup>(1)</sup>

		MIN	MAX	UNIT
V <sub>CC</sub>	Supply voltage	-0.3	6	V
V <sub>D1</sub> , V <sub>D2</sub>	Output switch voltage		14	V
I <sub>D1P</sub> , I <sub>D2P</sub>	Peak output switch current		500	mA
P <sub>TOT</sub>	Continuous power dissipation		250	mW
T <sub>J</sub>	Junction temperature		170	°C

- (1) Stresses beyond those listed under Absolute Maximum Ratings cause permanent damage to the device. These are stress ratings only and functional operation of the device at these or any other conditions beyond those indicated under [Recommended Operating Conditions](#) is not implied. Exposure to absolute-maximum-rated conditions for extended periods affects device reliability.

### 6.2 Handling Ratings

		MIN	MAX	UNIT	
T <sub>stg</sub>	Storage temperature range	-65	150	°C	
V <sub>(ESD)</sub>	Electrostatic discharge	Human body model (HBM), per ANSI/ESDA/JEDEC JS-001, all pins <sup>(1)</sup>	-4	4	kV
		Charged device model (CDM), per JEDEC specification JESD22-C101, all pins <sup>(2)</sup>	-1.5	1.5	
		Machine Model JEDEC JESD22-A115-A	-200	200	V

- (1) JEDEC document JEP155 states that 500-V HBM allows safe manufacturing with a standard ESD control process.  
 (2) JEDEC document JEP157 states that 250-V CDM allows safe manufacturing with a standard ESD control process.

### 6.3 Recommended Operating Conditions

				MIN	TYP	MAX	UNIT
V <sub>CC</sub>	Supply voltage			3		5.5	V
V <sub>D1</sub> , V <sub>D2</sub>	Output switch voltage	V <sub>CC</sub> = 5 V ± 10%,	When connected to Transformer with primary winding Center-tapped	0		11	V
		V <sub>CC</sub> = 3.3 V ± 10%		0		7.2	
I <sub>D1</sub> , I <sub>D2</sub>	D1 and D2 output switch current – Primary-side	V <sub>CC</sub> = 5 V ± 10%	V <sub>D1</sub> , V <sub>D2</sub> Swing ≥ 3.8 V, see <a href="#">Figure 32</a> for typical characteristics			350	mA
		V <sub>CC</sub> = 3.3 V ± 10%	V <sub>D1</sub> , V <sub>D2</sub> Swing ≥ 2.5 V, see <a href="#">Figure 31</a> for typical characteristics			150	
T <sub>A</sub>	Ambient temperature			–40		125	°C

### 6.4 Thermal Information

THERMAL METRIC <sup>(1)</sup>		SN6501	UNIT
		DBV 5-PINS	
θ <sub>JA</sub>	Junction-to-ambient thermal resistance	208.3	°C/W
θ <sub>JCtop</sub>	Junction-to-case (top) thermal resistance	87.1	
θ <sub>JB</sub>	Junction-to-board thermal resistance	40.4	
ψ <sub>JT</sub>	Junction-to-top characterization parameter	5.2	
ψ <sub>JB</sub>	Junction-to-board characterization parameter	39.7	
θ <sub>JCbot</sub>	Junction-to-case (bottom) thermal resistance	N/A	

(1) For more information about traditional and new thermal metrics, see the *IC Package Thermal Metrics* application report, [SPRA953](#).

### 6.5 Electrical Characteristics

over full-range of recommended operating conditions, unless otherwise noted

PARAMETER	TEST CONDITIONS	MIN	TYP	MAX	UNIT
R <sub>ON</sub>	V <sub>CC</sub> = 3.3 V ± 10%, See <a href="#">Figure 36</a>		1	3	Ω
	V <sub>CC</sub> = 5 V ± 10%, See <a href="#">Figure 36</a>		0.6	2	
I <sub>CC</sub>	V <sub>CC</sub> = 3.3 V ± 10%, no load		150	400	μA
	V <sub>CC</sub> = 5 V ± 10%, no load		300	700	
f <sub>ST</sub>	V <sub>CC</sub> = 2.4 V, See <a href="#">Figure 36</a>		300		kHz
f <sub>SW</sub>	V <sub>CC</sub> = 3.3 V ± 10%, See <a href="#">Figure 36</a>	250	360	550	kHz
	V <sub>CC</sub> = 5 V ± 10%, See <a href="#">Figure 36</a>	300	410	620	

(1) Average supply current is the current used by SN6501 only. It does not include load current.

### 6.6 Switching Characteristics

over operating free-air temperature range (unless otherwise noted)

PARAMETER	TEST CONDITIONS	MIN	TYP	MAX	UNIT
t <sub>r-D</sub>	V <sub>CC</sub> = 3.3 V ± 10%, See <a href="#">Figure 36</a>		70		ns
	V <sub>CC</sub> = 5 V ± 10%, See <a href="#">Figure 36</a>		80		
t <sub>f-D</sub>	V <sub>CC</sub> = 3.3 V ± 10%, See <a href="#">Figure 36</a>		110		ns
	V <sub>CC</sub> = 5 V ± 10%, See <a href="#">Figure 36</a>		60		
t <sub>BBM</sub>	V <sub>CC</sub> = 3.3 V ± 10%, See <a href="#">Figure 36</a>		150		ns
	V <sub>CC</sub> = 5 V ± 10%, See <a href="#">Figure 36</a>		50		

### 6.7 Typical Characteristics

TP1 Curves are measured with the Circuit in [Figure 33](#); whereas, TP1 and TP2 Curves are measured with Circuit in [Figure 35](#) ( $T_A = 25^\circ\text{C}$  unless otherwise noted). See [Table 3](#) for Transformer Specifications.

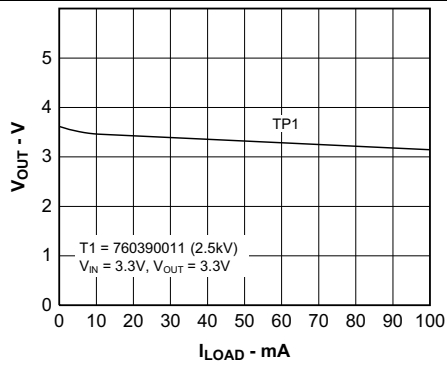

Figure 1. Output Voltage vs Load Current

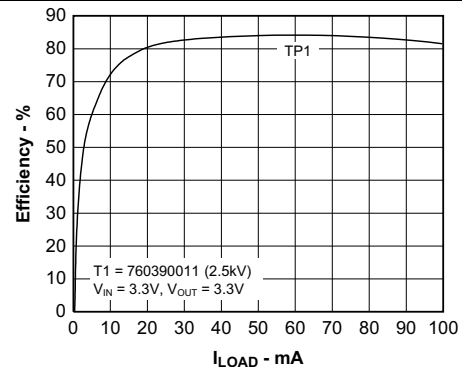

Figure 2. Efficiency vs Load Current

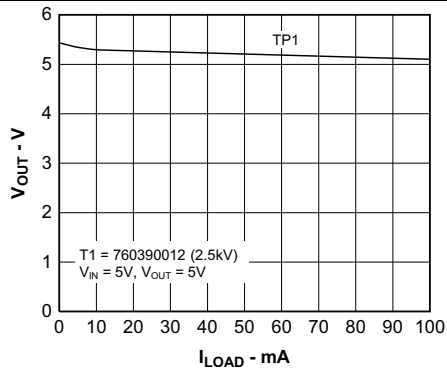

Figure 3. Output Voltage vs Load Current

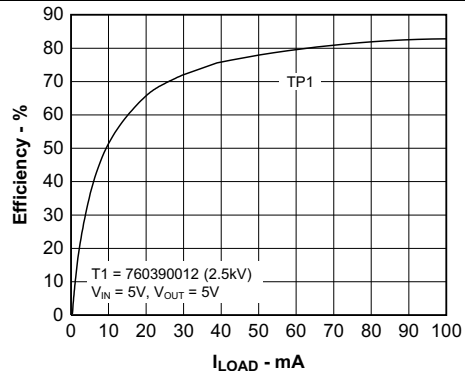

Figure 4. Efficiency vs Load Current

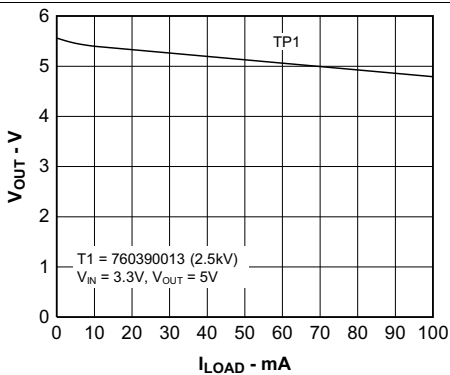

Figure 5. Output Voltage vs Load Current

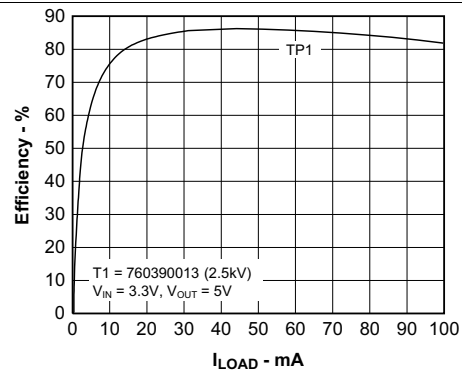

Figure 6. Efficiency vs Load Current

Typical Characteristics (continued)

TP1 Curves are measured with the Circuit in Figure 33; whereas, TP1 and TP2 Curves are measured with Circuit in Figure 35 ( $T_A = 25^\circ\text{C}$  unless otherwise noted). See Table 3 for Transformer Specifications.

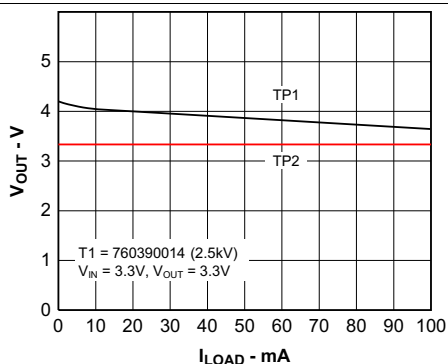

Figure 7. Output Voltage vs Load Current

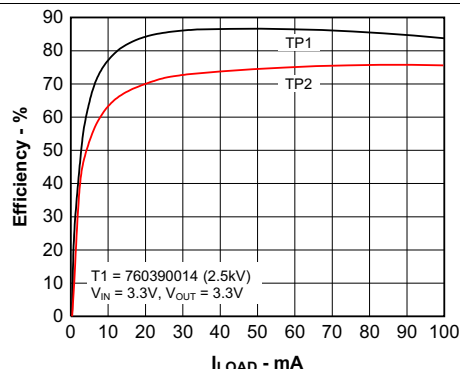

Figure 8. Efficiency vs Load Current

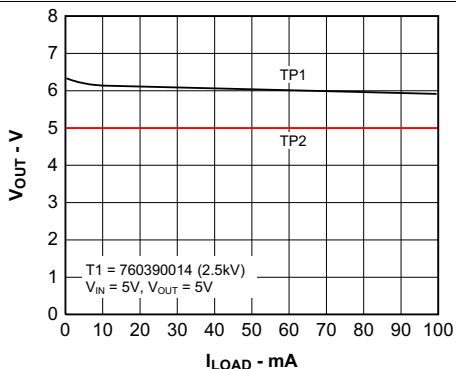

Figure 9. Output Voltage vs Load Current

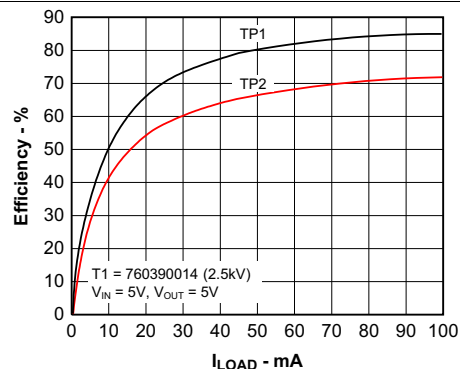

Figure 10. Efficiency vs Load Current

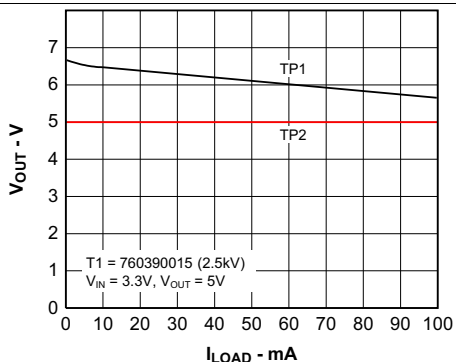

Figure 11. Output Voltage vs Load Current

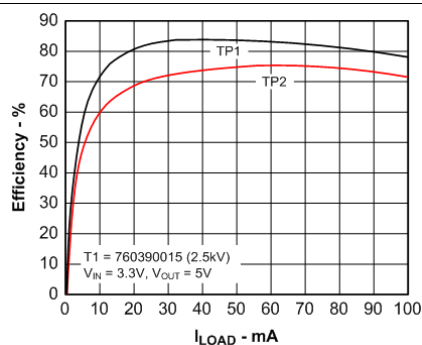

Figure 12. Efficiency vs Load Current

**Typical Characteristics (continued)**

TP1 Curves are measured with the Circuit in Figure 33; whereas, TP1 and TP2 Curves are measured with Circuit in Figure 35 ( $T_A = 25^\circ\text{C}$  unless otherwise noted). See Table 3 for Transformer Specifications.

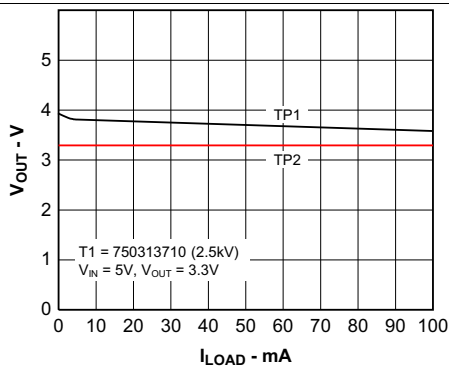

Figure 13. Output Voltage vs Load Current

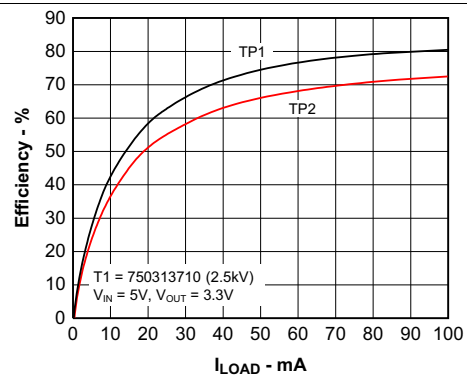

Figure 14. Efficiency vs Load Current

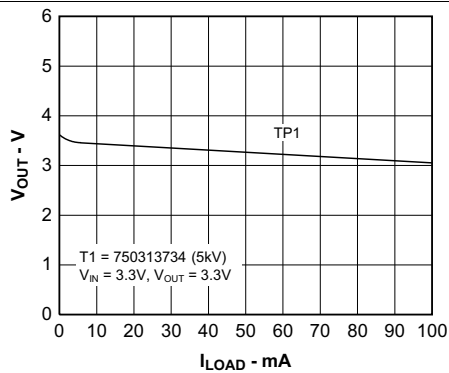

Figure 15. Output Voltage vs Load Current

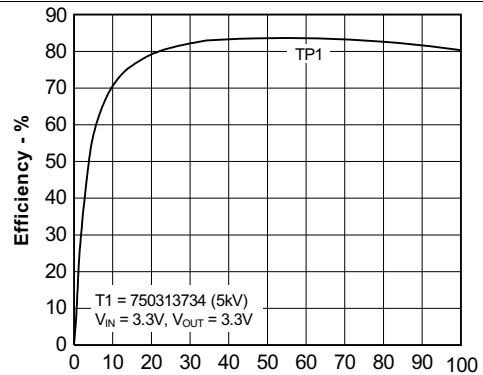

Figure 16. Efficiency vs Load Current

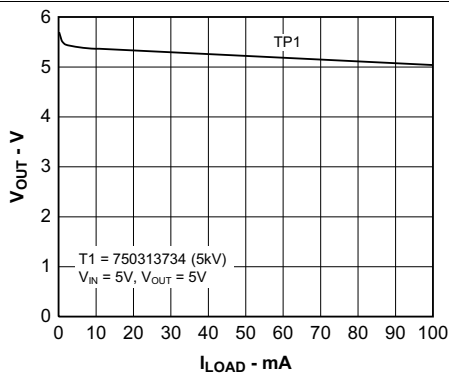

Figure 17. Output Voltage vs Load Current

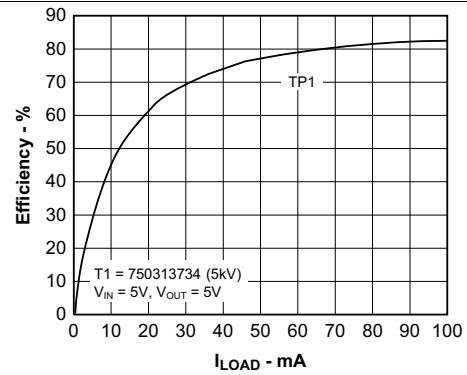

Figure 18. Efficiency vs Load Current

Typical Characteristics (continued)

TP1 Curves are measured with the Circuit in Figure 33; whereas, TP1 and TP2 Curves are measured with Circuit in Figure 35 (T<sub>A</sub> = 25°C unless otherwise noted). See Table 3 for Transformer Specifications.

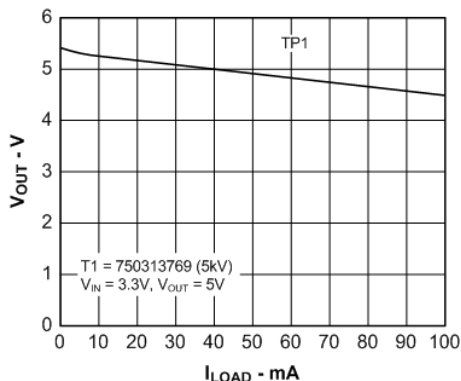

Figure 19. Output Voltage vs Load Current

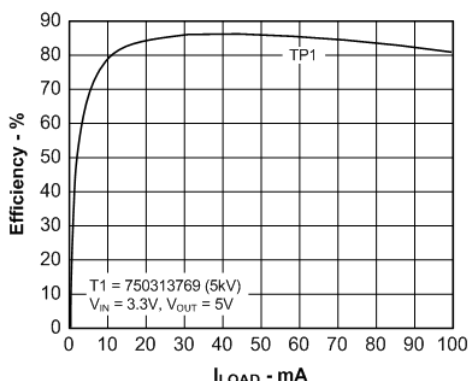

Figure 20. Efficiency vs Load Current

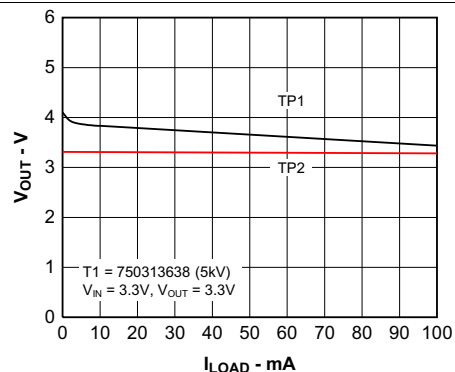

Figure 21. Output Voltage vs Load Current

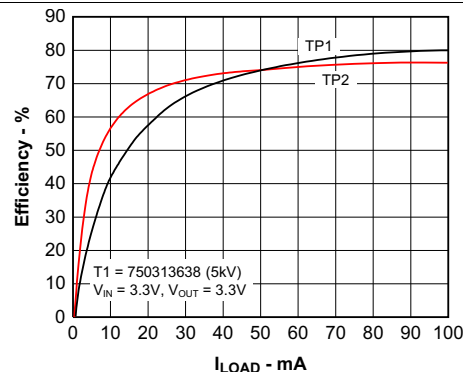

Figure 22. Efficiency vs Load Current

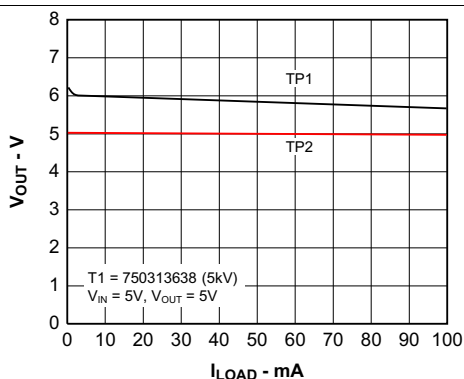

Figure 23. Output Voltage vs Load Current

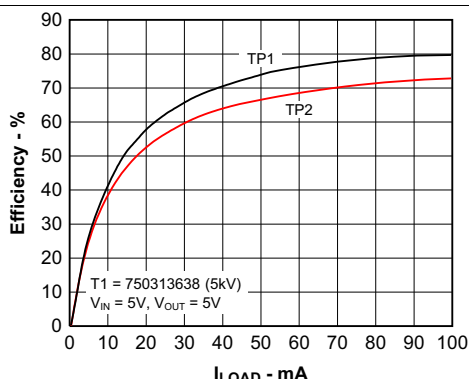

Figure 24. Efficiency vs Load Current

Typical Characteristics (continued)

TP1 Curves are measured with the Circuit in Figure 33; whereas, TP1 and TP2 Curves are measured with Circuit in Figure 35 ( $T_A = 25^\circ\text{C}$  unless otherwise noted). See Table 3 for Transformer Specifications.

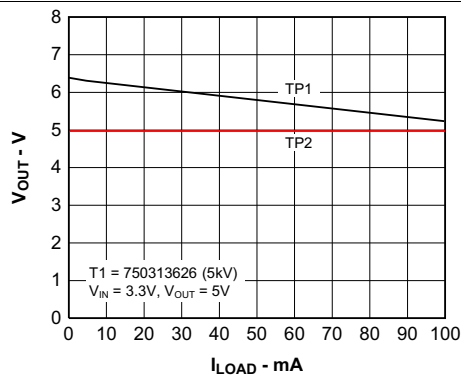

Figure 25. Output Voltage vs Load Current

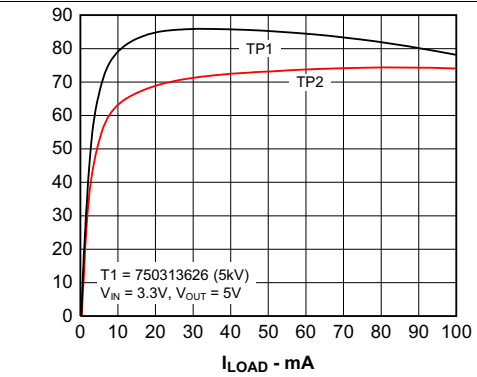

Figure 26. Efficiency vs Load Current

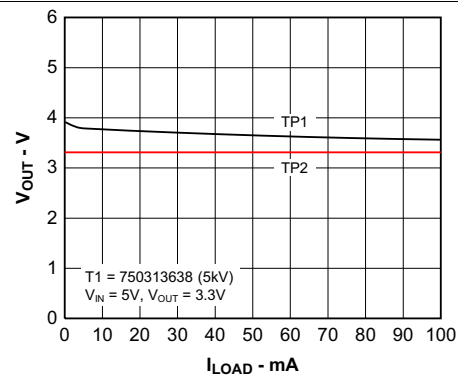

Figure 27. Output Voltage vs Load Current

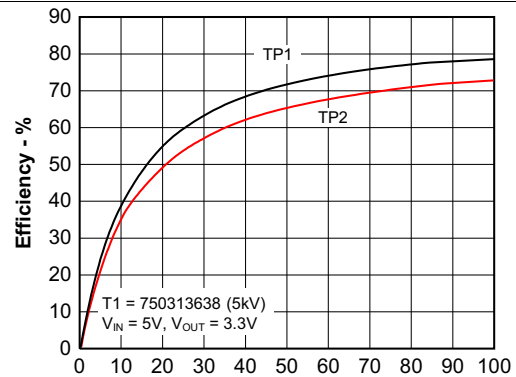

Figure 28. Efficiency vs Load Current

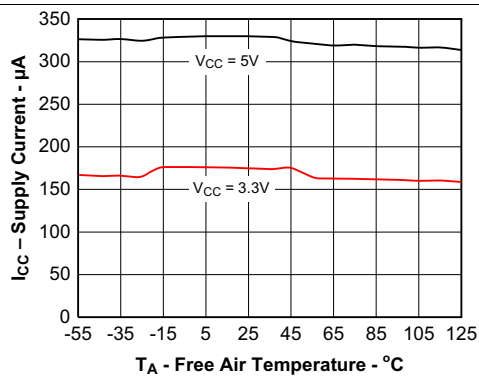

Figure 29. Average Supply Current vs Free-Air Temperature

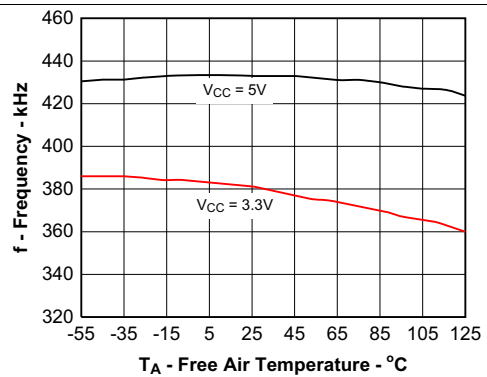
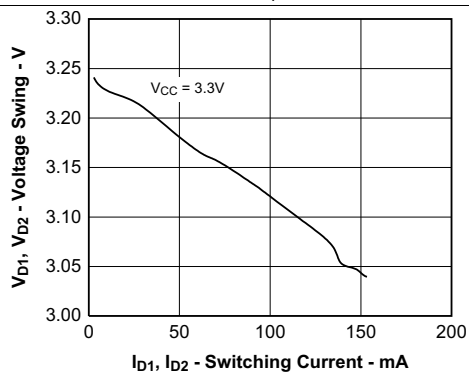

Figure 30. D1, D2 Switching Frequency vs Free-Air Temperature

**Typical Characteristics (continued)**

TP1 Curves are measured with the Circuit in Figure 33; whereas, TP1 and TP2 Curves are measured with Circuit in Figure 35 ( $T_A = 25^\circ\text{C}$  unless otherwise noted). See Table 3 for Transformer Specifications.



**Figure 31. D1, D2 Primary-Side Output Switch Voltage Swing vs Current**

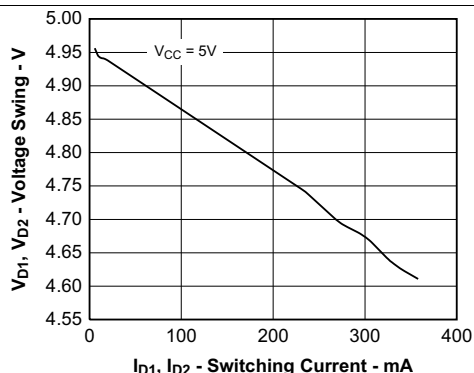

**Figure 32. D1, D2 Primary-Side Output Switch Voltage Swing vs Current**

## 7 Parameter Measurement Information

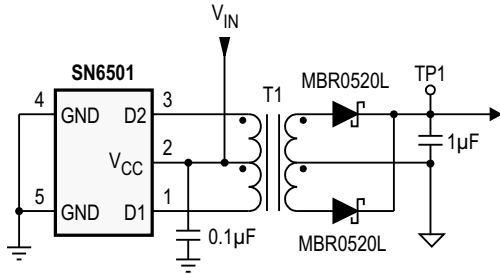

Figure 33. Measurement Circuit for Unregulated Output (TP1)

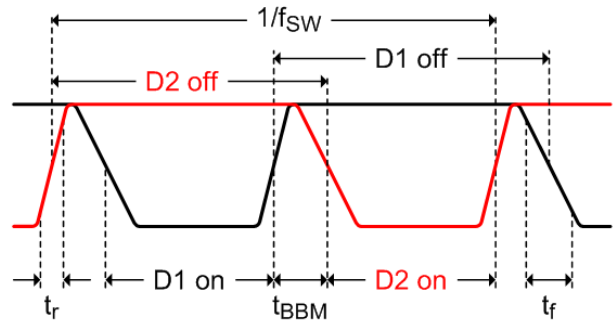

Figure 34. Timing Diagram

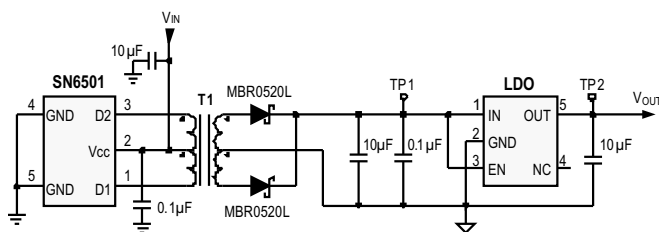

Figure 35. Measurement Circuit for regulated Output (TP1 and TP2)

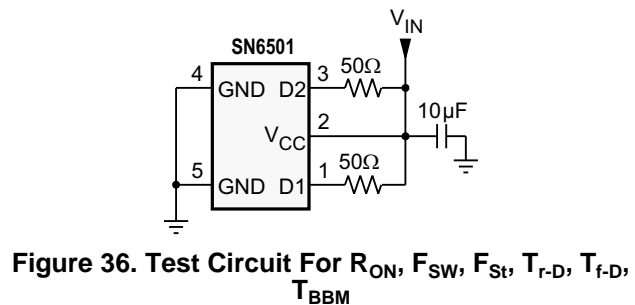

Figure 36. Test Circuit For  $R_{ON}$ ,  $F_{SW}$ ,  $F_{St}$ ,  $T_{r-D}$ ,  $T_{f-D}$ ,  $T_{BBM}$

## 8 Detailed Description

### 8.1 Overview

The SN6501 is a transformer driver designed for low-cost, small form-factor, isolated DC-DC converters utilizing the push-pull topology. The device includes an oscillator that feeds a gate-drive circuit. The gate-drive, comprising a frequency divider and a break-before-make (BBM) logic, provides two complementary output signals which alternately turn the two output transistors on and off.

The output frequency of the oscillator is divided down by an asynchronous divider that provides two complementary output signals with a 50% duty cycle. A subsequent break-before-make logic inserts a dead-time between the high-pulses of the two signals. The resulting output signals, present the gate-drive signals for the output transistors. As shown in the functional block diagram, before either one of the gates can assume logic high, there must be a short time period during which both signals are low and both transistors are high-impedance. This short period, known as break-before-make time, is required to avoid shorting out both ends of the primary.

### 8.2 Functional Block Diagram

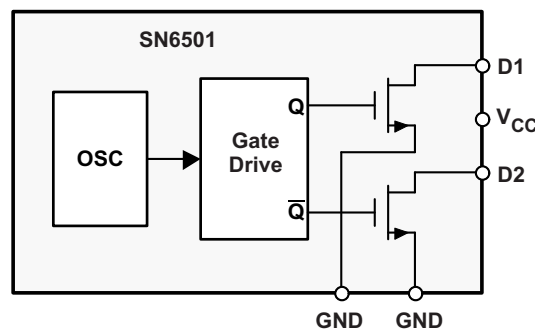

### 8.3 Feature Description

#### 8.3.1 Push-Pull Converter

Push-pull converters require transformers with center-taps to transfer power from the primary to the secondary (see Figure 37).

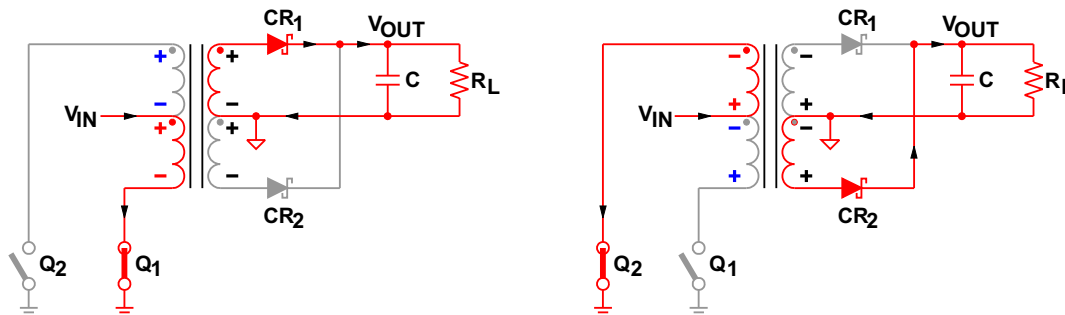

Figure 37. Switching Cycles of a Push-Pull Converter

When  $Q_1$  conducts,  $V_{IN}$  drives a current through the lower half of the primary to ground, thus creating a negative voltage potential at the lower primary end with regards to the  $V_{IN}$  potential at the center-tap.

At the same time the voltage across the upper half of the primary is such that the upper primary end is positive with regards to the center-tap in order to maintain the previously established current flow through  $Q_2$ , which now has turned high-impedance. The two voltage sources, each of which equaling  $V_{IN}$ , appear in series and cause a voltage potential at the open end of the primary of  $2 \times V_{IN}$  with regards to ground.

Per dot convention the same voltage polarities that occur at the primary also occur at the secondary. The positive potential of the upper secondary end therefore forward biases diode  $CR_1$ . The secondary current starting from the upper secondary end flows through  $CR_1$ , charges capacitor  $C$ , and returns through the load impedance  $R_L$  back to the center-tap.

When  $Q_2$  conducts,  $Q_1$  goes high-impedance and the voltage polarities at the primary and secondary reverse. Now the lower end of the primary presents the open end with a  $2 \times V_{IN}$  potential against ground. In this case  $CR_2$  is forward biased while  $CR_1$  is reverse biased and current flows from the lower secondary end through  $CR_2$ , charging the capacitor and returning through the load to the center-tap.

#### 8.3.2 Core Magnetization

Figure 38 shows the ideal magnetizing curve for a push-pull converter with  $B$  as the magnetic flux density and  $H$  as the magnetic field strength. When  $Q_1$  conducts the magnetic flux is pushed from  $A$  to  $A'$ , and when  $Q_2$  conducts the flux is pulled back from  $A'$  to  $A$ . The difference in flux and thus in flux density is proportional to the product of the primary voltage,  $V_P$ , and the time,  $t_{ON}$ , it is applied to the primary:  $B \approx V_P \times t_{ON}$ .

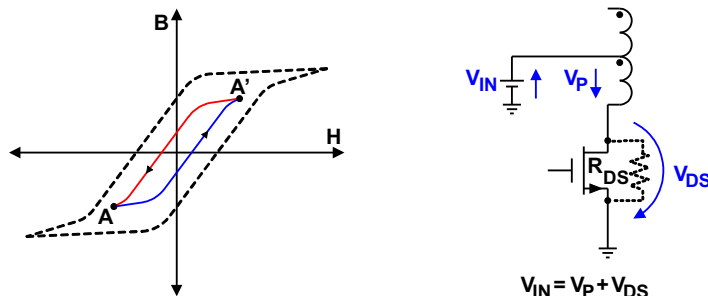

Figure 38. Core Magnetization and Self-Regulation Through Positive Temperature Coefficient of  $R_{DS(on)}$

This volt-seconds ( $V$ - $t$ ) product is important as it determines the core magnetization during each switching cycle. If the  $V$ - $t$  products of both phases are not identical, an imbalance in flux density swing results with an offset from the origin of the  $B$ - $H$  curve. If balance is not restored, the offset increases with each following cycle and the transformer slowly creeps toward the saturation region.

## Feature Description (continued)

Fortunately, due to the positive temperature coefficient of a MOSFET's on-resistance, the output FETs of the SN6501 have a self-correcting effect on V-t imbalance. In the case of a slightly longer on-time, the prolonged current flow through a FET gradually heats the transistor which leads to an increase in  $R_{DS-on}$ . The higher resistance then causes the drain-source voltage,  $V_{DS}$ , to rise. Because the voltage at the primary is the difference between the constant input voltage,  $V_{IN}$ , and the voltage drop across the MOSFET,  $V_P = V_{IN} - V_{DS}$ ,  $V_P$  is gradually reduced and V-t balance restored.

### 8.4 Device Functional Modes

The functional modes of the SN6501 are divided into start-up, operating, and off-mode.

#### 8.4.1 Start-Up Mode

When the supply voltage at  $V_{CC}$  ramps up to 2.4V typical, the internal oscillator starts operating at a start frequency of 300 kHz. The output stage begins switching but the amplitude of the drain signals at D1 and D2 has not reached its full maximum yet.

#### 8.4.2 Operating Mode

When the device supply has reached its nominal value  $\pm 10\%$  the oscillator is fully operating. However variations over supply voltage and operating temperature can vary the switching frequencies at D1 and D2 between 250 kHz and 550 kHz for  $V_{CC} = 3.3\text{ V} \pm 10\%$ , and between 300 kHz and 620 kHz for  $V_{CC} = 5\text{ V} \pm 10\%$ .

#### 8.4.3 Off-Mode

The SN6501 is deactivated by reducing  $V_{CC}$  to 0 V. In this state both drain outputs, D1 and D2, are high-impedance.

## 9 Application and Implementation

### NOTE

Information in the following applications sections is not part of the TI component specification, and TI does not warrant its accuracy or completeness. TI's customers are responsible for determining suitability of components for their purposes. Customers should validate and test their design implementation to confirm system functionality.

### 9.1 Application Information

The SN6501 is a transformer driver designed for low-cost, small form-factor, isolated DC-DC converters utilizing the push-pull topology. The device includes an oscillator that feeds a gate-drive circuit. The gate-drive, comprising a frequency divider and a break-before-make (BBM) logic, provides two complementary output signals which alternately turn the two output transistors on and off.

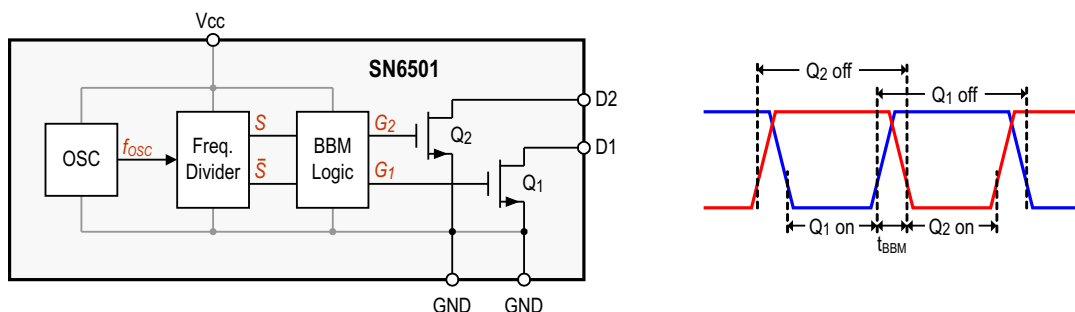

Figure 39. SN6501 Block Diagram And Output Timing With Break-Before-Make Action

The output frequency of the oscillator is divided down by an asynchronous divider that provides two complementary output signals, S and  $\bar{S}$ , with a 50% duty cycle. A subsequent break-before-make logic inserts a dead-time between the high-pulses of the two signals. The resulting output signals, G<sub>1</sub> and G<sub>2</sub>, present the gate-drive signals for the output transistors Q<sub>1</sub> and Q<sub>2</sub>. As shown in Figure 40, before either one of the gates can assume logic high, there must be a short time period during which both signals are low and both transistors are high-impedance. This short period, known as break-before-make time, is required to avoid shorting out both ends of the primary.

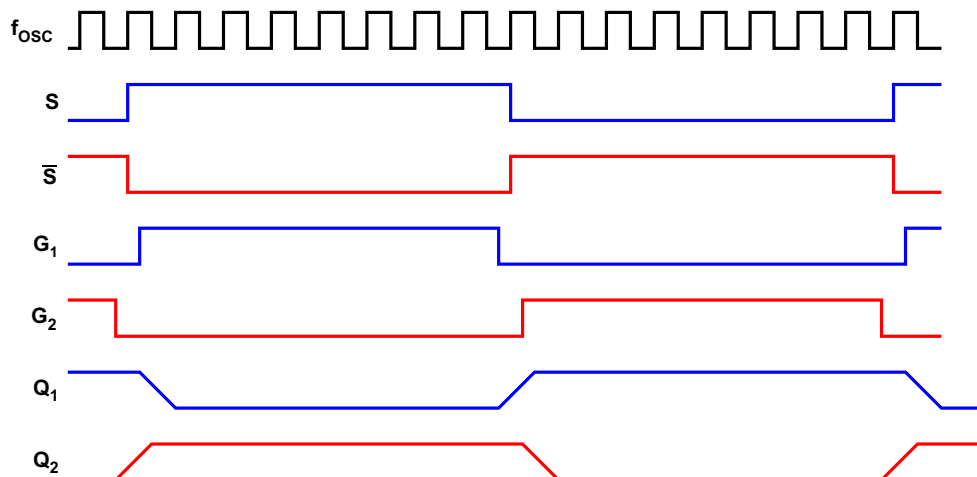
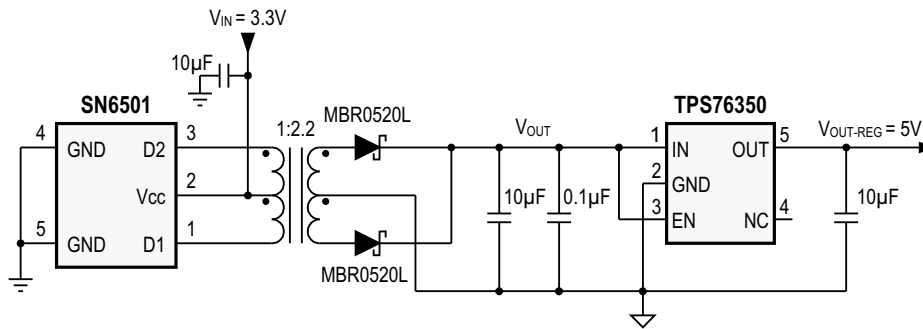

Figure 40. Detailed Output Signal Waveforms

## 9.2 Typical Application



**Figure 41. Typical Application Schematic (SN6501)**

### 9.2.1 Design Requirements

For this design example, use the parameters listed in [Table 1](#) as design parameters.

**Table 1. Design Parameters**

DESIGN PARAMETER	EXAMPLE VALUE
Input voltage range	3.3 V ± 3%
Output voltage	5 V
Maximum load current	100 mA

### 9.2.2 Detailed Design Procedure

The following recommendations on components selection focus on the design of an efficient push-pull converter with high current drive capability. Contrary to popular belief, the output voltage of the unregulated converter output drops significantly over a wide range in load current. The characteristic curve in [Figure 11](#) for example shows that the difference between  $V_{OUT}$  at minimum load and  $V_{OUT}$  at maximum load exceeds a transceiver's supply range. Therefore, in order to provide a stable, load independent supply while maintaining maximum possible efficiency the implementation of a low dropout regulator (LDO) is strongly advised.

The final converter circuit is shown in [Figure 45](#). The measured  $V_{OUT}$  and efficiency characteristics for the regulated and unregulated outputs are shown in [Figure 1](#) to [Figure 28](#).

#### 9.2.2.1 SN6501 Drive Capability

The SN6501 transformer driver is designed for low-power push-pull converters with input and output voltages in the range of 3 V to 5.5 V. While converter designs with higher output voltages are possible, care must be taken that higher turns ratios don't lead to primary currents that exceed the SN6501 specified current limits.

#### 9.2.2.2 LDO Selection

The minimum requirements for a suitable low dropout regulator are:

- Its current drive capability should slightly exceed the specified load current of the application to prevent the LDO from dropping out of regulation. Therefore for a load current of 100 mA, choose a 100 mA to 150 mA LDO. While regulators with higher drive capabilities are acceptable, they also usually possess higher dropout voltages that will reduce overall converter efficiency.
- The internal dropout voltage,  $V_{DO}$ , at the specified load current should be as low as possible to maintain efficiency. For a low-cost 150 mA LDO, a  $V_{DO}$  of 150 mV at 100 mA is common. Be aware however, that this lower value is usually specified at room temperature and can increase by a factor of 2 over temperature, which in turn will raise the required minimum input voltage.
- The required minimum input voltage preventing the regulator from dropping out of line regulation is given with:

$$V_{I-min} = V_{DO-max} + V_{O-max} \quad (1)$$

This means in order to determine  $V_I$  for worst-case condition, the user must take the maximum values for  $V_{DO}$  and  $V_O$  specified in the LDO data sheet for rated output current (i.e., 100 mA) and add them together. Also specify that the output voltage of the push-pull rectifier at the specified load current is equal or higher than  $V_{I-min}$ . If it is not, the LDO will lose line-regulation and any variations at the input will pass straight through to the output. Hence below  $V_{I-min}$  the output voltage will follow the input and the regulator behaves like a simple conductor.

- The maximum regulator input voltage must be higher than the rectifier output under no-load. Under this condition there is no secondary current reflected back to the primary, thus making the voltage drop across  $R_{DS-on}$  negligible and allowing the entire converter input voltage to drop across the primary. At this point the secondary reaches its maximum voltage of

$$V_{S-max} = V_{IN-max} \times n \tag{2}$$

with  $V_{IN-max}$  as the maximum converter input voltage and  $n$  as the transformer turns ratio. Thus to prevent the LDO from damage the maximum regulator input voltage must be higher than  $V_{S-max}$ . Table 2 lists the maximum secondary voltages for various turns ratios commonly applied in push-pull converters with 100 mA output drive.

**Table 2. Required Maximum LDO Input Voltages for Various Push-Pull Configurations**

PUSH-PULL CONVERTER				LDO
CONFIGURATION	$V_{IN-max}$ [V]	URNS-RATIO	$V_{S-max}$ [V]	$V_{I-max}$ [V]
3.3 $V_{IN}$ to 3.3 $V_{OUT}$	3.6	1.5 ± 3%	5.6	6 to 10
3.3 $V_{IN}$ to 5 $V_{OUT}$	3.6	2.2 ± 3%	8.2	10
5 $V_{IN}$ to 5 $V_{OUT}$	5.5	1.5 ± 3%	8.5	10

**9.2.2.3 Diode Selection**

A rectifier diode should always possess low-forward voltage to provide as much voltage to the converter output as possible. When used in high-frequency switching applications, such as the SN6501 however, the diode must also possess a short recovery time. Schottky diodes meet both requirements and are therefore strongly recommended in push-pull converter designs. A good choice for low-volt applications and ambient temperatures of up to 85°C is the low-cost Schottky rectifier MBR0520L with a typical forward voltage of 275 mV at 100-mA forward current. For higher output voltages such as ±10 V and above use the MBR0530 which provides a higher DC blocking voltage of 30 V.

Lab measurements have shown that at temperatures higher than 100°C the leakage currents of the above Schottky diodes increase significantly. This can cause thermal runaway leading to the collapse of the rectifier output voltage. Therefore, for ambient temperatures higher than 85°C use low-leakage Schottky diodes, such as RB168M-40.

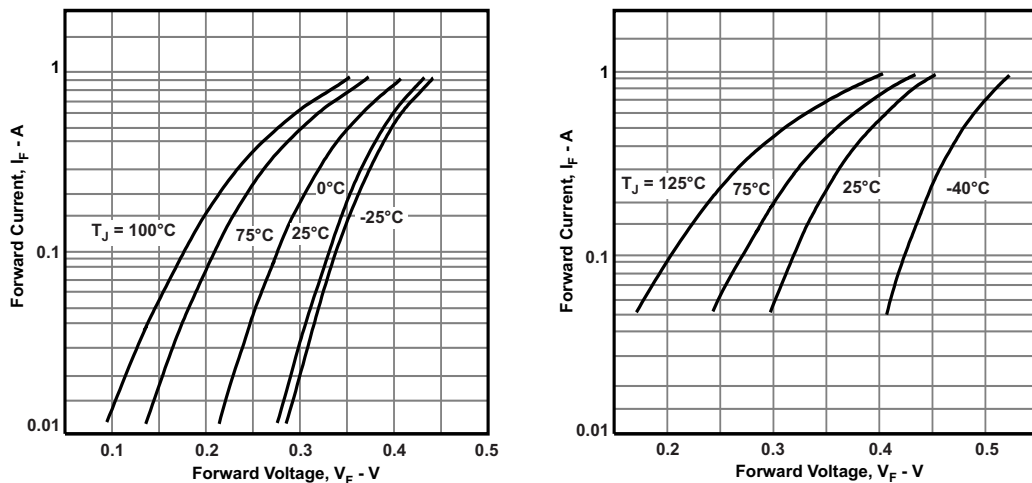

**Figure 42. Diode Forward Characteristics for MBR0520L (Left) and MBR0530 (Right)**

### 9.2.2.4 Capacitor Selection

The capacitors in the converter circuit in [Figure 45](#) are multi-layer ceramic chip (MLCC) capacitors.

As with all high speed CMOS ICs, the SN6501 requires a bypass capacitor in the range of 10 nF to 100 nF.

The input bulk capacitor at the center-tap of the primary supports large currents into the primary during the fast switching transients. For minimum ripple make this capacitor 1  $\mu$ F to 10  $\mu$ F. In a 2-layer PCB design with a dedicated ground plane, place this capacitor close to the primary center-tap to minimize trace inductance. In a 4-layer board design with low-inductance reference planes for ground and  $V_{IN}$ , the capacitor can be placed at the supply entrance of the board. To ensure low-inductance paths use two vias in parallel for each connection to a reference plane or to the primary center-tap.

The bulk capacitor at the rectifier output smoothes the output voltage. Make this capacitor 1  $\mu$ F to 10  $\mu$ F.

The small capacitor at the regulator input is not necessarily required. However, good analog design practice suggests, using a small value of 47 nF to 100 nF improves the regulator's transient response and noise rejection.

The LDO output capacitor buffers the regulated output for the subsequent isolator and transceiver circuitry. The choice of output capacitor depends on the LDO stability requirements specified in the data sheet. However, in most cases, a low-ESR ceramic capacitor in the range of 4.7  $\mu$ F to 10  $\mu$ F will satisfy these requirements.

### 9.2.2.5 Transformer Selection

#### 9.2.2.5.1 V-t Product Calculation

To prevent a transformer from saturation its V-t product must be greater than the maximum V-t product applied by the SN6501. The maximum voltage delivered by the SN6501 is the nominal converter input plus 10%. The maximum time this voltage is applied to the primary is half the period of the lowest frequency at the specified input voltage. Therefore, the transformer's minimum V-t product is determined through:

$$Vt_{\min} \geq V_{IN-\max} \times \frac{T_{\max}}{2} = \frac{V_{IN-\max}}{2 \times f_{\min}} \quad (3)$$

Inserting the numeric values from the data sheet into the equation above yields the minimum V-t products of

$$Vt_{\min} \geq \frac{3.6 \text{ V}}{2 \times 250 \text{ kHz}} = 7.2 \text{ V}\mu\text{s} \quad \text{for 3.3 V, and}$$

$$Vt_{\min} \geq \frac{5.5 \text{ V}}{2 \times 300 \text{ kHz}} = 9.1 \text{ V}\mu\text{s} \quad \text{for 5 V applications.} \quad (4)$$

Common V-t values for low-power center-tapped transformers range from 22  $\text{V}\mu\text{s}$  to 150  $\text{V}\mu\text{s}$  with typical footprints of 10 mm x 12 mm. However, transformers specifically designed for PCMCIA applications provide as little as 11  $\text{V}\mu\text{s}$  and come with a significantly reduced footprint of 6 mm x 6 mm only.

While Vt-wise all of these transformers can be driven by the SN6501, other important factors such as isolation voltage, transformer wattage, and turns ratio must be considered before making the final decision.

#### 9.2.2.5.2 Turns Ratio Estimate

Assume the rectifier diodes and linear regulator has been selected. Also, it has been determined that the transformer chosen must have a V-t product of at least 11  $\text{V}\mu\text{s}$ . However, before searching the manufacturer websites for a suitable transformer, the user still needs to know its minimum turns ratio that allows the push-pull converter to operate flawlessly over the specified current and temperature range. This minimum transformation ratio is expressed through the ratio of minimum secondary to minimum primary voltage multiplied by a correction factor that takes the transformer's typical efficiency of 97% into account:

$$V_{P-\min} = V_{IN-\min} - V_{DS-\max} \quad (5)$$

$V_{S-\min}$  must be large enough to allow for a maximum voltage drop,  $V_{F-\max}$ , across the rectifier diode and still provide sufficient input voltage for the regulator to remain in regulation. From the LDO SELECTION section, this minimum input voltage is known and by adding  $V_{F-\max}$  gives the minimum secondary voltage with:

$$V_{S-\min} = V_{F-\max} + V_{DO-\max} + V_{O-\max} \quad (6)$$

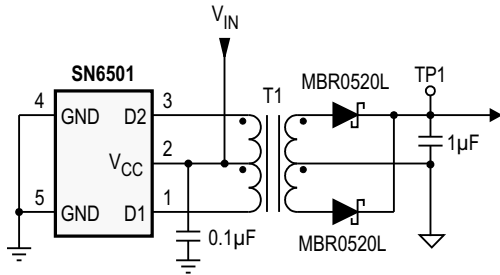
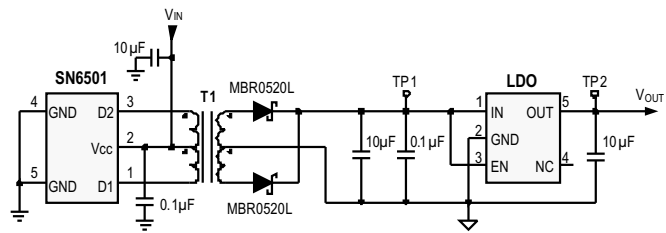

**Figure 44. Unregulated Output for Low-Current Loads With Wide Supply Range**

**Figure 45. Regulated Output for Stable Supplies and High Current Loads**

The Würth Electronics Midcom isolation transformers in [Table 3](#) are optimized designs for the SN6501, providing high efficiency and small form factor at low-cost.

The 1:1.1 and 1:1.7 turns-ratios are designed for logic applications with wide supply rails and low load currents. These applications operate without LDO, thus achieving further cost-reduction.

**Table 3. Recommended Isolation Transformers Optimized for SN6501**

Turns Ratio	V x T (Vµs)	Isolation (V <sub>RMS</sub> )	Dimensions (mm)	Application	LDO	Figures	Order No.	Manufacturer	
1:1.1 ±2%	7	2500	6.73 x 10.05 x 4.19	3.3 V → 3.3 V	No	<a href="#">Figure 1</a> <a href="#">Figure 2</a>	760390011	Würth Electronics/ Midcom	
1:1.1 ±2%				5 V → 5 V		<a href="#">Figure 3</a> <a href="#">Figure 4</a>	760390012		
1:1.7 ±2%				3.3 V → 5 V		<a href="#">Figure 5</a> <a href="#">Figure 6</a>	760390013		
1:1.3 ±2%	11			5000	3.3 V → 3.3 V 5 V → 5 V	Yes	<a href="#">Figure 7</a> <a href="#">Figure 8</a> <a href="#">Figure 9</a> <a href="#">Figure 10</a>		760390014
1:2.1 ±2%					3.3 V → 5 V		<a href="#">Figure 11</a> <a href="#">Figure 12</a>		760390015
1.23:1 ±2%					5 V → 3.3 V		<a href="#">Figure 13</a> <a href="#">Figure 14</a>		750313710
1:1.1 ±2%	11	5000	9.14 x 12.7 x 7.37	3.3 V → 3.3 V	No	<a href="#">Figure 15</a> <a href="#">Figure 16</a>	750313734		
1:1.1 ±2%				5 V → 5 V		<a href="#">Figure 17</a> <a href="#">Figure 18</a>	750313734		
1:1.7 ±2%				3.3 V → 5 V		<a href="#">Figure 19</a> <a href="#">Figure 20</a>	750313769		
1:1.3 ±2%	11	5000	9.14 x 12.7 x 7.37	3.3 V → 3.3 V 5 V → 5 V	Yes	<a href="#">Figure 21</a> <a href="#">Figure 22</a> <a href="#">Figure 23</a> <a href="#">Figure 24</a>	750313638		
1:2.1 ±2%				3.3 V → 5 V		<a href="#">Figure 25</a> <a href="#">Figure 26</a>	750313626		
1.3:1 ±2%				5 V → 3.3 V		<a href="#">Figure 27</a> <a href="#">Figure 28</a>	750313638		

### 9.2.3 Application Curve

See [Table 3](#) for application curves.

### 9.2.4 Higher Output Voltage Designs

The SN6501 can drive push-pull converters that provide high output voltages of up to 30 V, or bipolar outputs of up to  $\pm 15$  V. Using commercially available center-tapped transformers, with their rather low turns ratios of 0.8 to 5, requires different rectifier topologies to achieve high output voltages. [Figure 46](#) to [Figure 49](#) show some of these topologies together with their respective open-circuit output voltages.

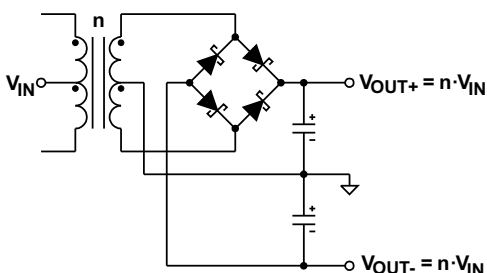

**Figure 46. Bridge Rectifier With Center-Tapped Secondary Enables Bipolar Outputs**

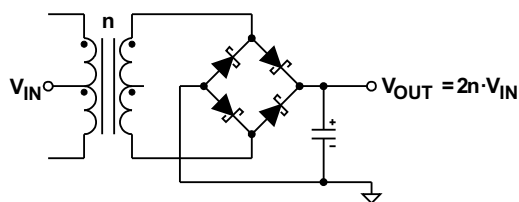

**Figure 47. Bridge Rectifier Without Center-Tapped Secondary Performs Voltage Doubling**

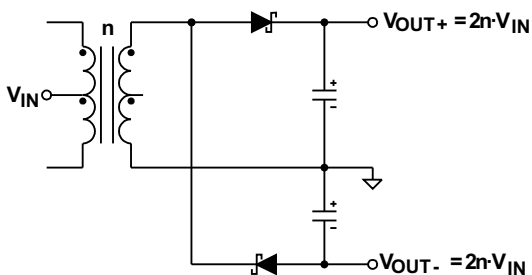

**Figure 48. Half-Wave Rectifier Without Center-Tapped Secondary Performs Voltage Doubling, Centered Ground Provides Bipolar Outputs**

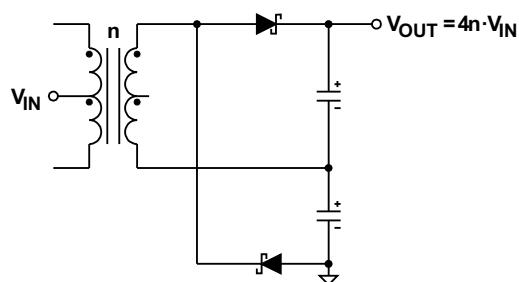

**Figure 49. Half-Wave Rectifier Without Centered Ground and Center-Tapped Secondary Performs Voltage Doubling Twice, Hence Quadrupling  $V_{IN}$**

### 9.2.5 Application Circuits

The following application circuits are shown for a 3.3 V input supply commonly taken from the local, regulated micro-controller supply. For 5 V input voltages requiring different turn ratios refer to the transformer manufacturers and their websites listed in [Table 4](#).

**Table 4. Transformer Manufacturers**

Coilcraft Inc.	<a href="http://www.coilcraft.com">http://www.coilcraft.com</a>
Halo-Electronics Inc.	<a href="http://www.haloelectronics.com">http://www.haloelectronics.com</a>
Murata Power Solutions	<a href="http://www.murata-ps.com">http://www.murata-ps.com</a>
Würth Electronics Midcom Inc	<a href="http://www.midcom-inc.com">http://www.midcom-inc.com</a>

SN6501

SLLSEA0G – FEBRUARY 2012 – REVISED SEPTEMBER 2014

www.ti.com

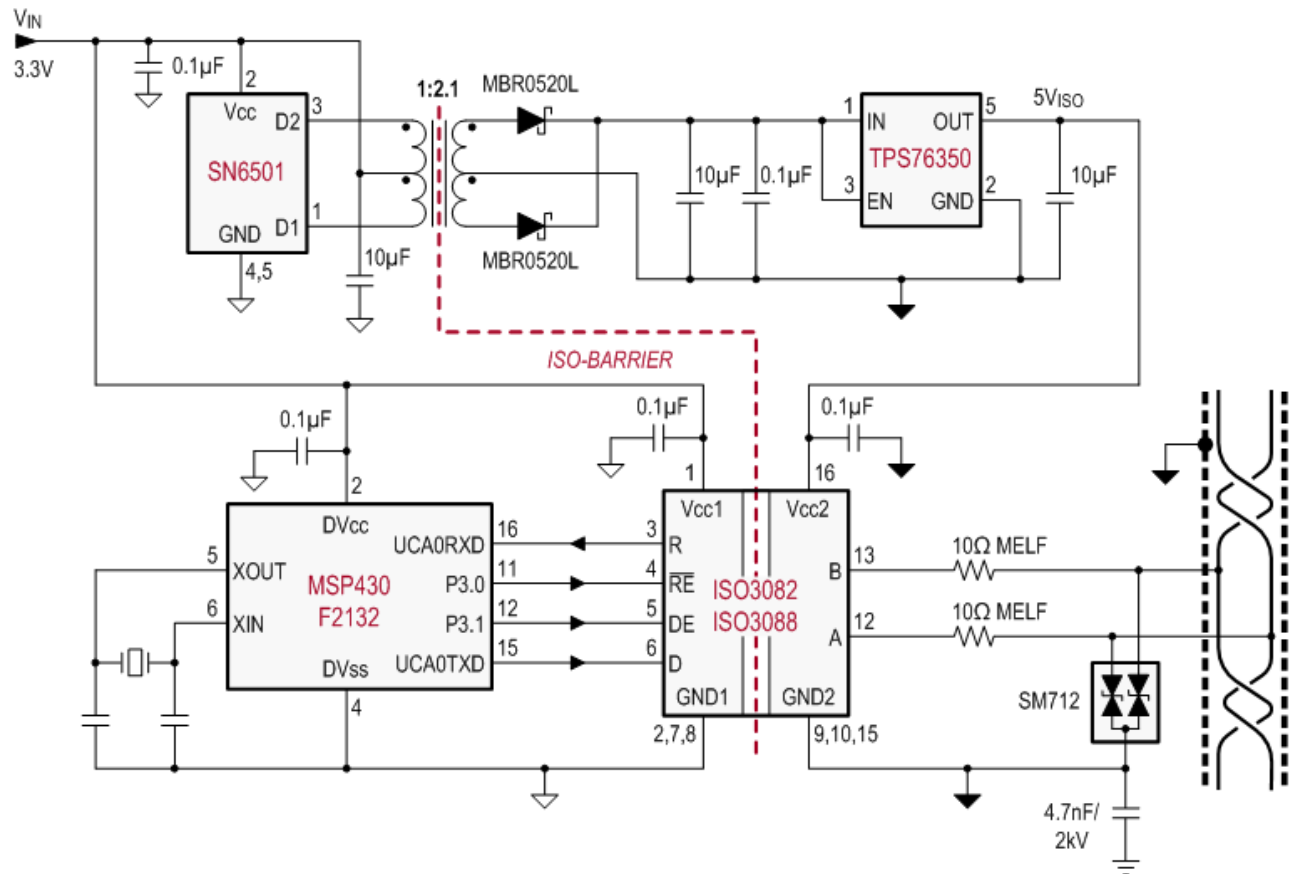

Figure 50. Isolated RS-485 Interface

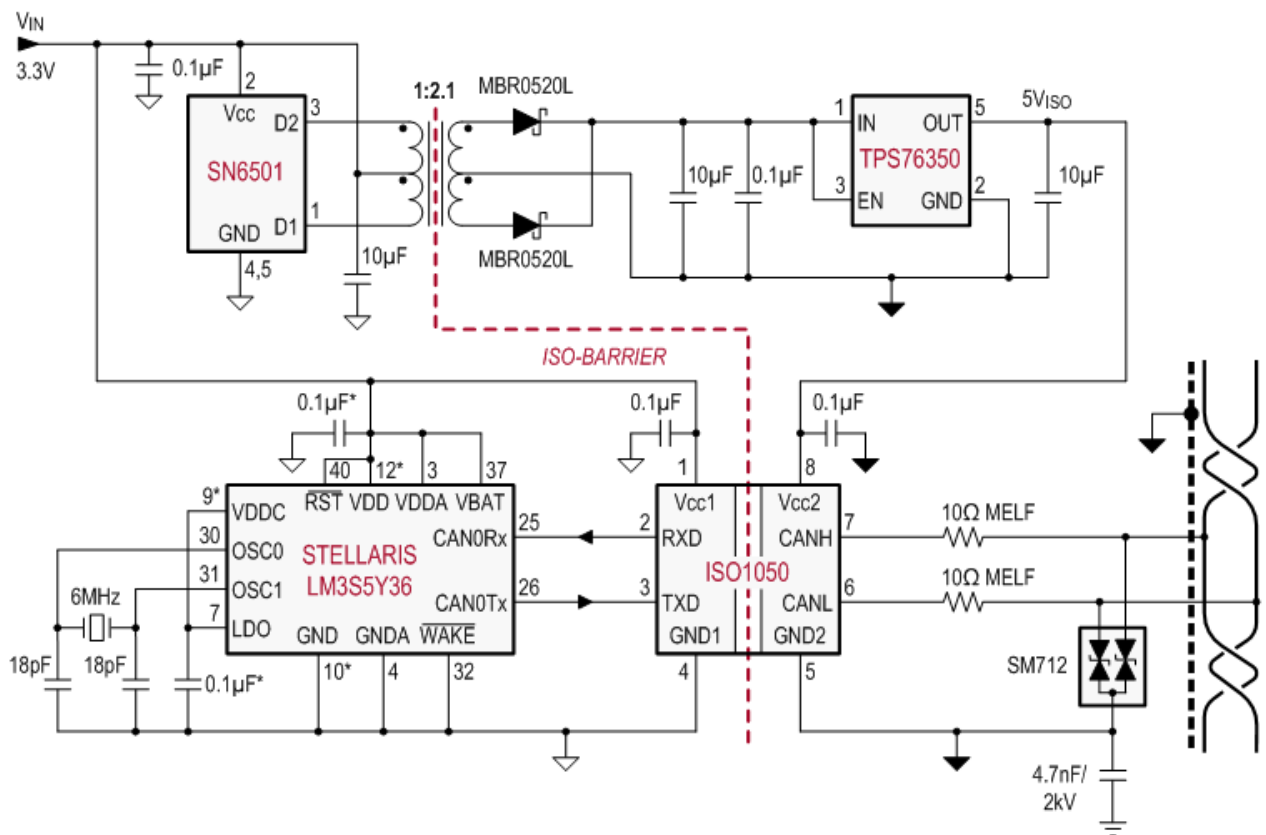

Figure 51. Isolated Can Interface

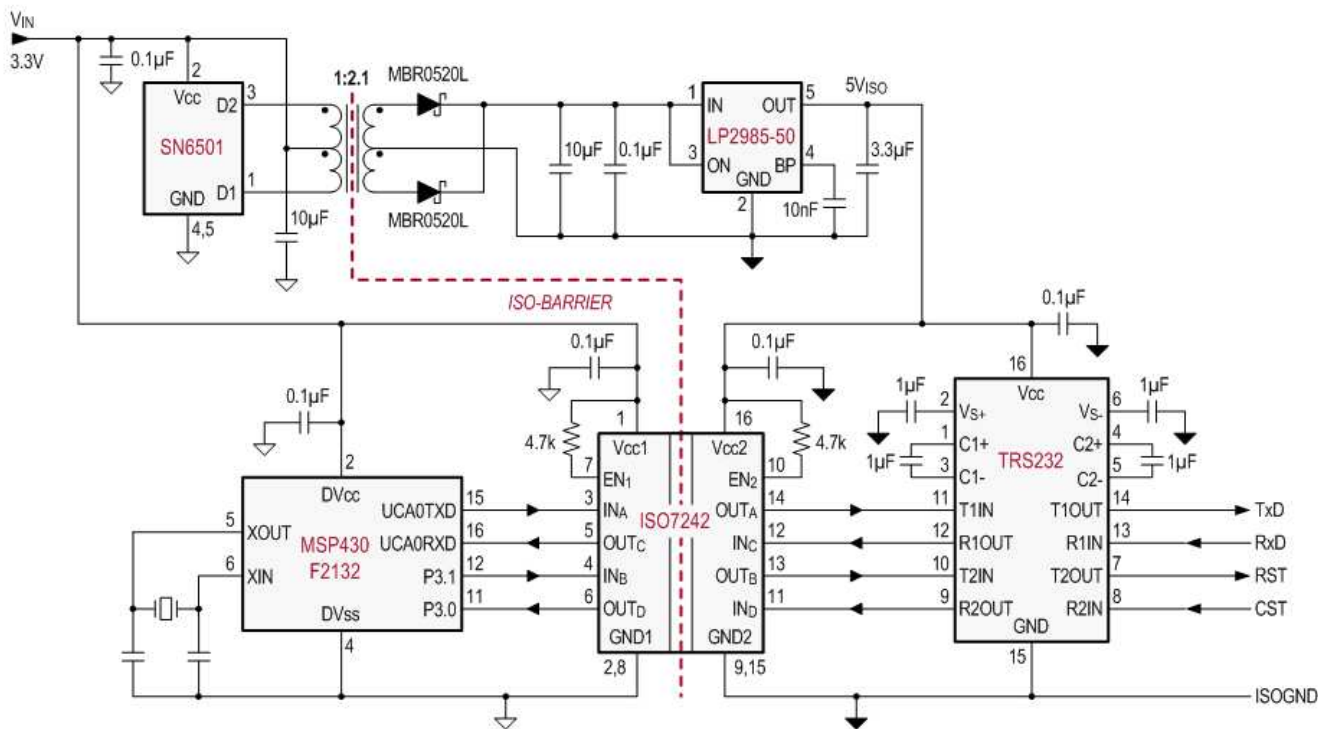

Figure 52. Isolated RS-232 Interface

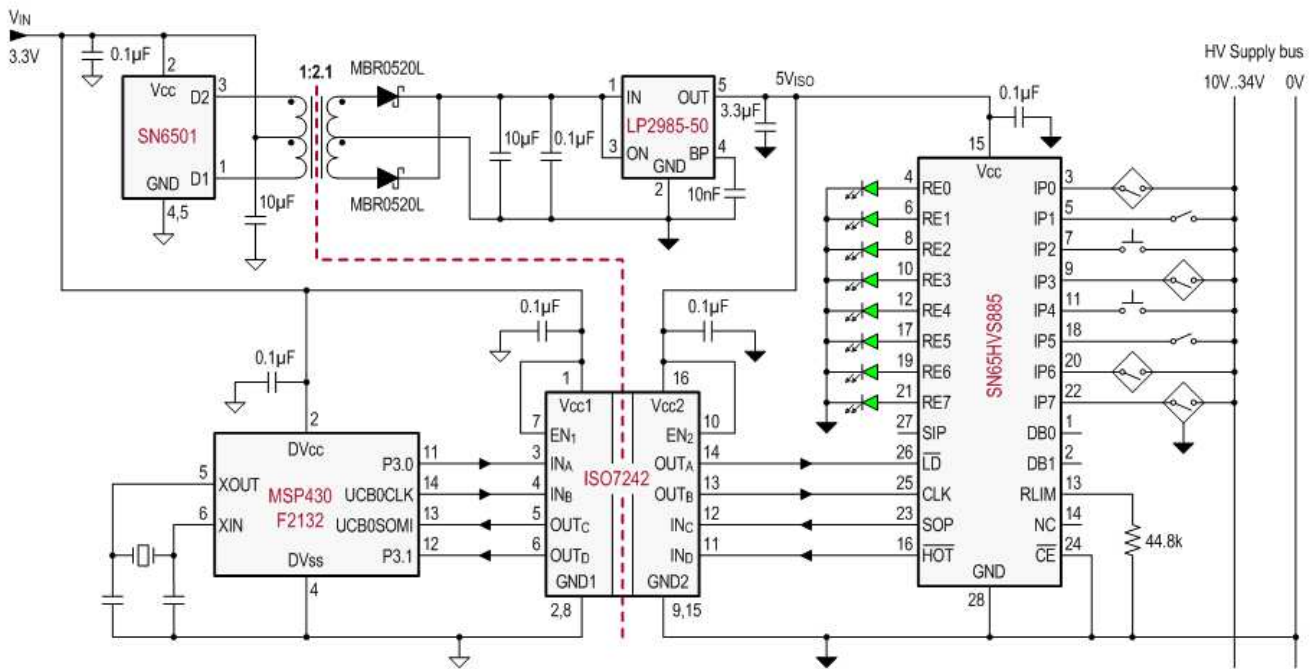

Figure 53. Isolated Digital Input Module

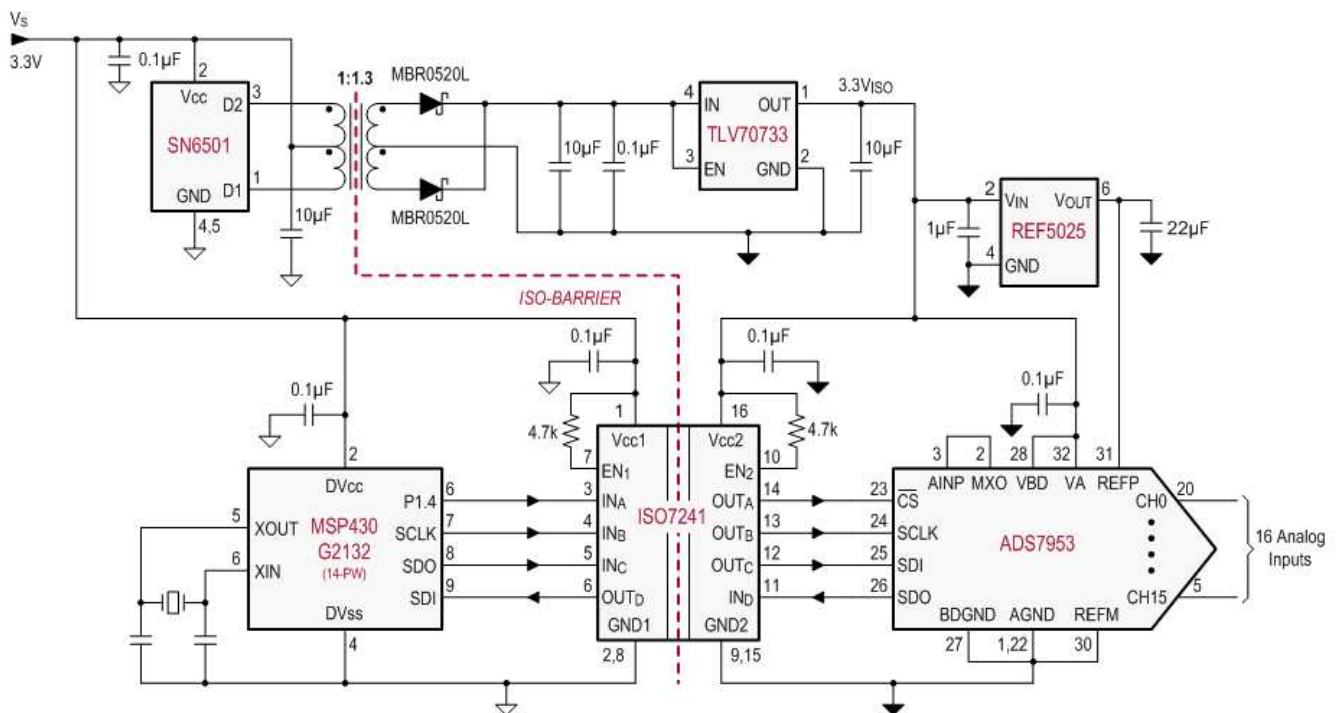

Figure 54. Isolated SPI Interface for an Analog Input Module With 16 Inputs

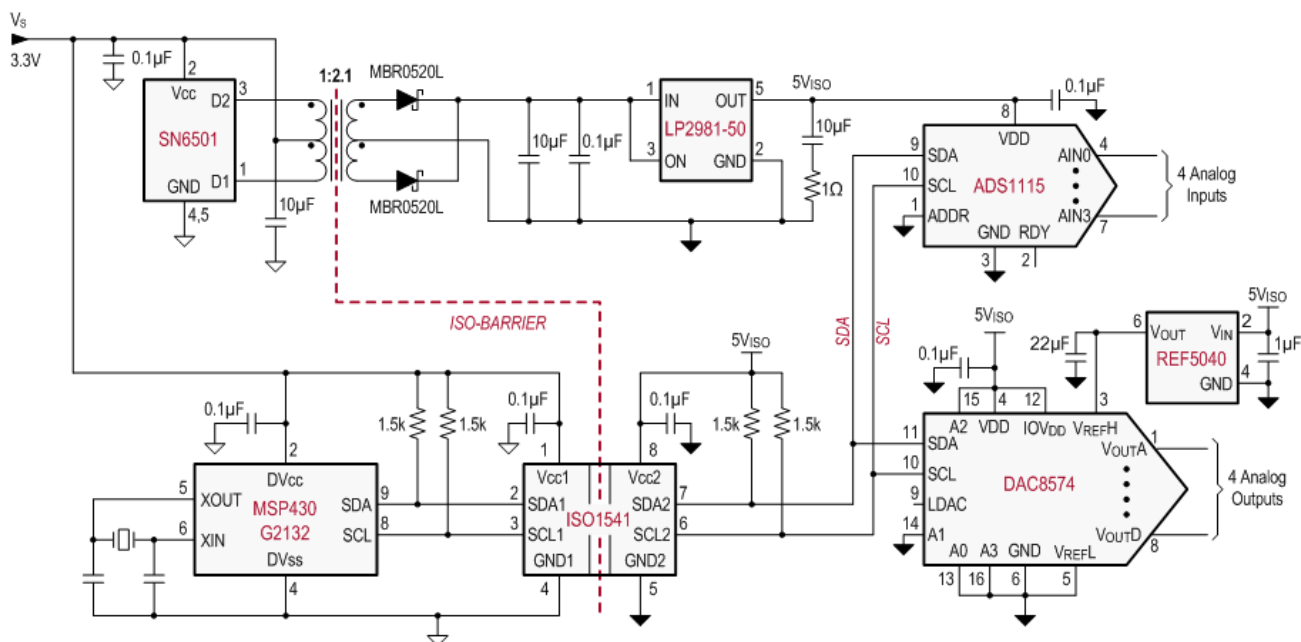

Figure 55. Isolated I<sup>2</sup>C Interface for an Analog Data Acquisition System With 4 Inputs and 4 Outputs

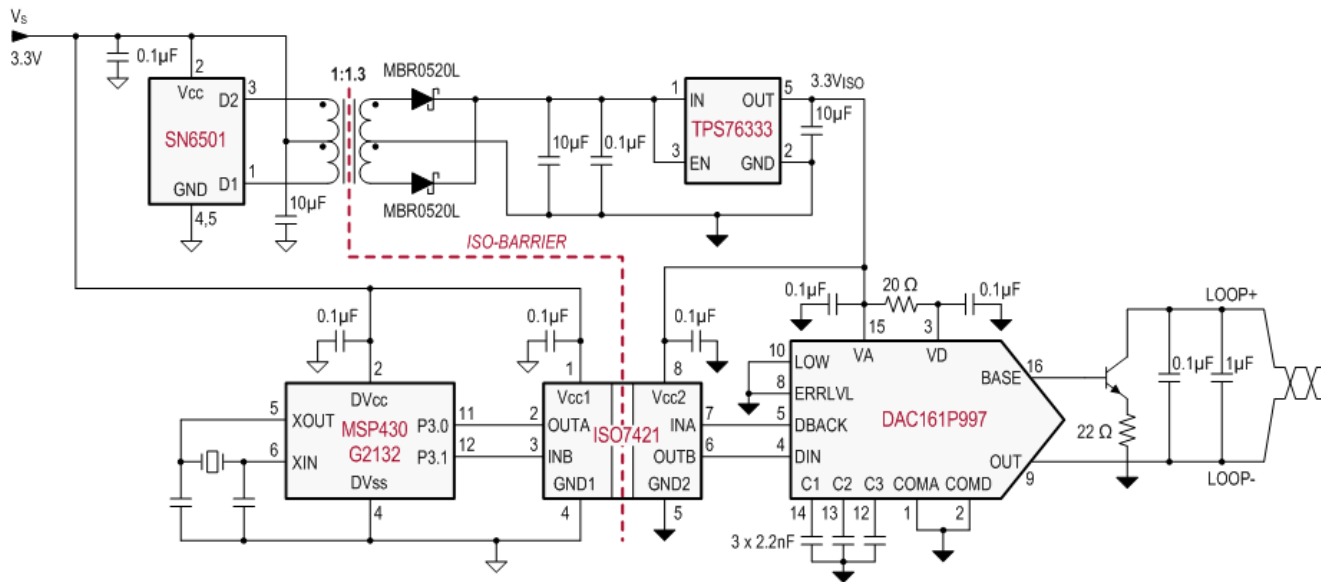

Figure 56. Isolated 4-20 mA Current Loop

## 10 Power Supply Recommendations

The device is designed to operate from an input voltage supply range between 3.3 V and 5 V nominal. This input supply must be regulated within  $\pm 10\%$ . If the input supply is located more than a few inches from the SN6501 a 0.1  $\mu\text{F}$  by-pass capacitor should be connected as possible to the device  $V_{\text{CC}}$  pin, and a 10  $\mu\text{F}$  capacitor should be connected close to the transformer center-tap pin.

## 11 Layout

### 11.1 Layout Guidelines

- The  $V_{\text{IN}}$  pin must be buffered to ground with a low-ESR ceramic bypass-capacitor. The recommended capacitor value can range from 1  $\mu\text{F}$  to 10  $\mu\text{F}$ . The capacitor must have a voltage rating of 10 V minimum and a X5R or X7R dielectric.
- The optimum placement is closest to the  $V_{\text{IN}}$  and GND pins at the board entrance to minimize the loop area formed by the bypass-capacitor connection, the  $V_{\text{IN}}$  terminal, and the GND pin. See [Figure 57](#) for a PCB layout example.
- The connections between the device D1 and D2 pins and the transformer primary endings, and the connection of the device  $V_{\text{CC}}$  pin and the transformer center-tap must be as close as possible for minimum trace inductance.
- The connection of the device  $V_{\text{CC}}$  pin and the transformer center-tap must be buffered to ground with a low-ESR ceramic bypass-capacitor. The recommended capacitor value can range from 1  $\mu\text{F}$  to 10  $\mu\text{F}$ . The capacitor must have a voltage rating of 16 V minimum and a X5R or X7R dielectric.
- The device GND pins must be tied to the PCB ground plane using two vias for minimum inductance.
- The ground connections of the capacitors and the ground plane should use two vias for minimum inductance.
- The rectifier diodes should be Schottky diodes with low forward voltage in the 10 mA to 100 mA current range to maximize efficiency.
- The  $V_{\text{OUT}}$  pin must be buffered to ISO-Ground with a low-ESR ceramic bypass-capacitor. The recommended capacitor value can range from 1  $\mu\text{F}$  to 10  $\mu\text{F}$ . The capacitor must have a voltage rating of 16 V minimum and a X5R or X7R dielectric.

### 11.2 Layout Example

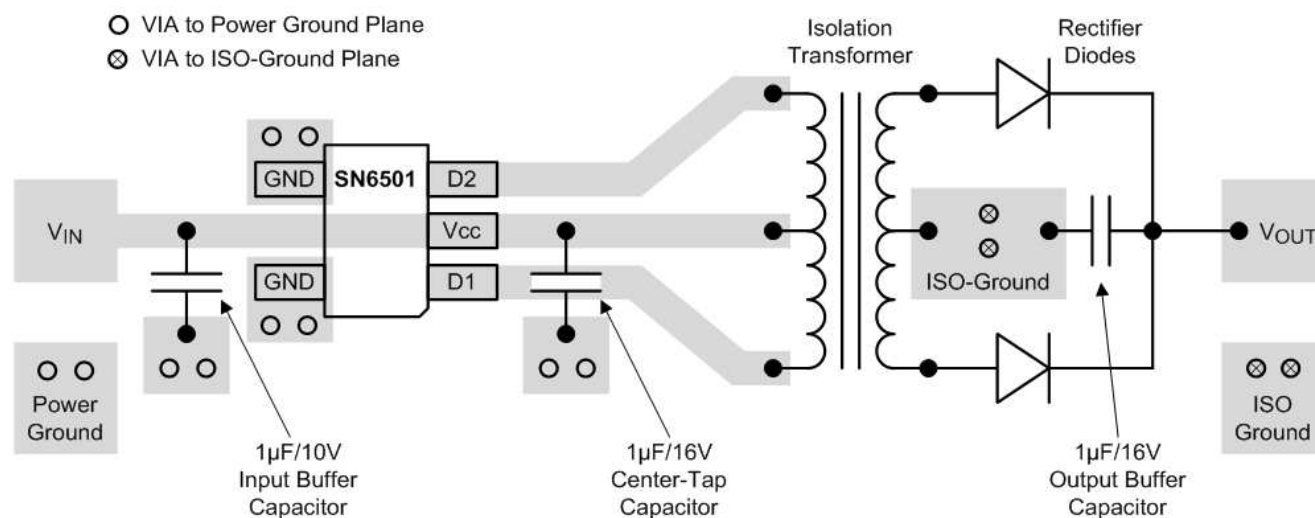

**Figure 57. Layout Example of a 2-Layer Board (SN6501)**

## 12 Device and Documentation Support

### 12.1 Device Support

#### 12.1.1 Third-Party Products Disclaimer

TI'S PUBLICATION OF INFORMATION REGARDING THIRD-PARTY PRODUCTS OR SERVICES DOES NOT CONSTITUTE AN ENDORSEMENT REGARDING THE SUITABILITY OF SUCH PRODUCTS OR SERVICES OR A WARRANTY, REPRESENTATION OR ENDORSEMENT OF SUCH PRODUCTS OR SERVICES, EITHER ALONE OR IN COMBINATION WITH ANY TI PRODUCT OR SERVICE.

### 12.2 Trademarks

All trademarks are the property of their respective owners.

### 12.3 Electrostatic Discharge Caution



These devices have limited built-in ESD protection. The leads should be shorted together or the device placed in conductive foam during storage or handling to prevent electrostatic damage to the MOS gates.

### 12.4 Glossary

[SLYZ022](#) — *TI Glossary*.

This glossary lists and explains terms, acronyms, and definitions.

## 13 Mechanical, Packaging, and Orderable Information

The following pages include mechanical, packaging, and orderable information. This information is the most current data available for the designated devices. This data is subject to change without notice and revision of this document. For browser-based versions of this data sheet, refer to the left-hand navigation.

**PACKAGING INFORMATION**

Orderable Device	Status (1)	Package Type	Package Drawing	Pins	Package Qty	Eco Plan (2)	Lead/Ball Finish (6)	MSL Peak Temp (3)	Op Temp (°C)	Device Marking (4/5)	Samples
SN6501DBVR	ACTIVE	SOT-23	DBV	5	3000	Green (RoHS & no Sb/Br)	CU NIPDAU	Level-1-260C-UNLIM	-40 to 125	6501	<a href="#">Samples</a>
SN6501DBVT	ACTIVE	SOT-23	DBV	5	250	Green (RoHS & no Sb/Br)	CU NIPDAU	Level-1-260C-UNLIM	-40 to 125	6501	<a href="#">Samples</a>

(1) The marketing status values are defined as follows:

**ACTIVE:** Product device recommended for new designs.

**LIFEBUY:** TI has announced that the device will be discontinued, and a lifetime-buy period is in effect.

**NRND:** Not recommended for new designs. Device is in production to support existing customers, but TI does not recommend using this part in a new design.

**PREVIEW:** Device has been announced but is not in production. Samples may or may not be available.

**OBSOLETE:** TI has discontinued the production of the device.

(2) Eco Plan - The planned eco-friendly classification: Pb-Free (RoHS), Pb-Free (RoHS Exempt), or Green (RoHS & no Sb/Br) - please check <http://www.ti.com/productcontent> for the latest availability information and additional product content details.

**TBD:** The Pb-Free/Green conversion plan has not been defined.

**Pb-Free (RoHS):** TI's terms "Lead-Free" or "Pb-Free" mean semiconductor products that are compatible with the current RoHS requirements for all 6 substances, including the requirement that lead not exceed 0.1% by weight in homogeneous materials. Where designed to be soldered at high temperatures, TI Pb-Free products are suitable for use in specified lead-free processes.

**Pb-Free (RoHS Exempt):** This component has a RoHS exemption for either 1) lead-based flip-chip solder bumps used between the die and package, or 2) lead-based die adhesive used between the die and leadframe. The component is otherwise considered Pb-Free (RoHS compatible) as defined above.

**Green (RoHS & no Sb/Br):** TI defines "Green" to mean Pb-Free (RoHS compatible), and free of Bromine (Br) and Antimony (Sb) based flame retardants (Br or Sb do not exceed 0.1% by weight in homogeneous material)

(3) MSL, Peak Temp. - The Moisture Sensitivity Level rating according to the JEDEC industry standard classifications, and peak solder temperature.

(4) There may be additional marking, which relates to the logo, the lot trace code information, or the environmental category on the device.

(5) Multiple Device Markings will be inside parentheses. Only one Device Marking contained in parentheses and separated by a "~" will appear on a device. If a line is indented then it is a continuation of the previous line and the two combined represent the entire Device Marking for that device.

(6) Lead/Ball Finish - Orderable Devices may have multiple material finish options. Finish options are separated by a vertical ruled line. Lead/Ball Finish values may wrap to two lines if the finish value exceeds the maximum column width.

**Important Information and Disclaimer:** The information provided on this page represents TI's knowledge and belief as of the date that it is provided. TI bases its knowledge and belief on information provided by third parties, and makes no representation or warranty as to the accuracy of such information. Efforts are underway to better integrate information from third parties. TI has taken and continues to take reasonable steps to provide representative and accurate information but may not have conducted destructive testing or chemical analysis on incoming materials and chemicals. TI and TI suppliers consider certain information to be proprietary, and thus CAS numbers and other limited information may not be available for release.

In no event shall TI's liability arising out of such information exceed the total purchase price of the TI part(s) at issue in this document sold by TI to Customer on an annual basis.

**OTHER QUALIFIED VERSIONS OF SN6501 :**

- Automotive: [SN6501-Q1](#)

**NOTE: Qualified Version Definitions:**

- Automotive - Q100 devices qualified for high-reliability automotive applications targeting zero defects

## TAPE AND REEL INFORMATION



### QUADRANT ASSIGNMENTS FOR PIN 1 ORIENTATION IN TAPE



\*All dimensions are nominal

Device	Package Type	Package Drawing	Pins	SPQ	Reel Diameter (mm)	Reel Width W1 (mm)	A0 (mm)	B0 (mm)	K0 (mm)	P1 (mm)	W (mm)	Pin1 Quadrant
SN6501DBVR	SOT-23	DBV	5	3000	178.0	9.0	3.3	3.2	1.4	4.0	8.0	Q3
SN6501DBVT	SOT-23	DBV	5	250	178.0	9.0	3.3	3.2	1.4	4.0	8.0	Q3

**TAPE AND REEL BOX DIMENSIONS**



\*All dimensions are nominal

Device	Package Type	Package Drawing	Pins	SPQ	Length (mm)	Width (mm)	Height (mm)
SN6501DBVR	SOT-23	DBV	5	3000	180.0	180.0	18.0
SN6501DBVT	SOT-23	DBV	5	250	180.0	180.0	18.0

# MECHANICAL DATA

DBV (R-PDSO-G5)

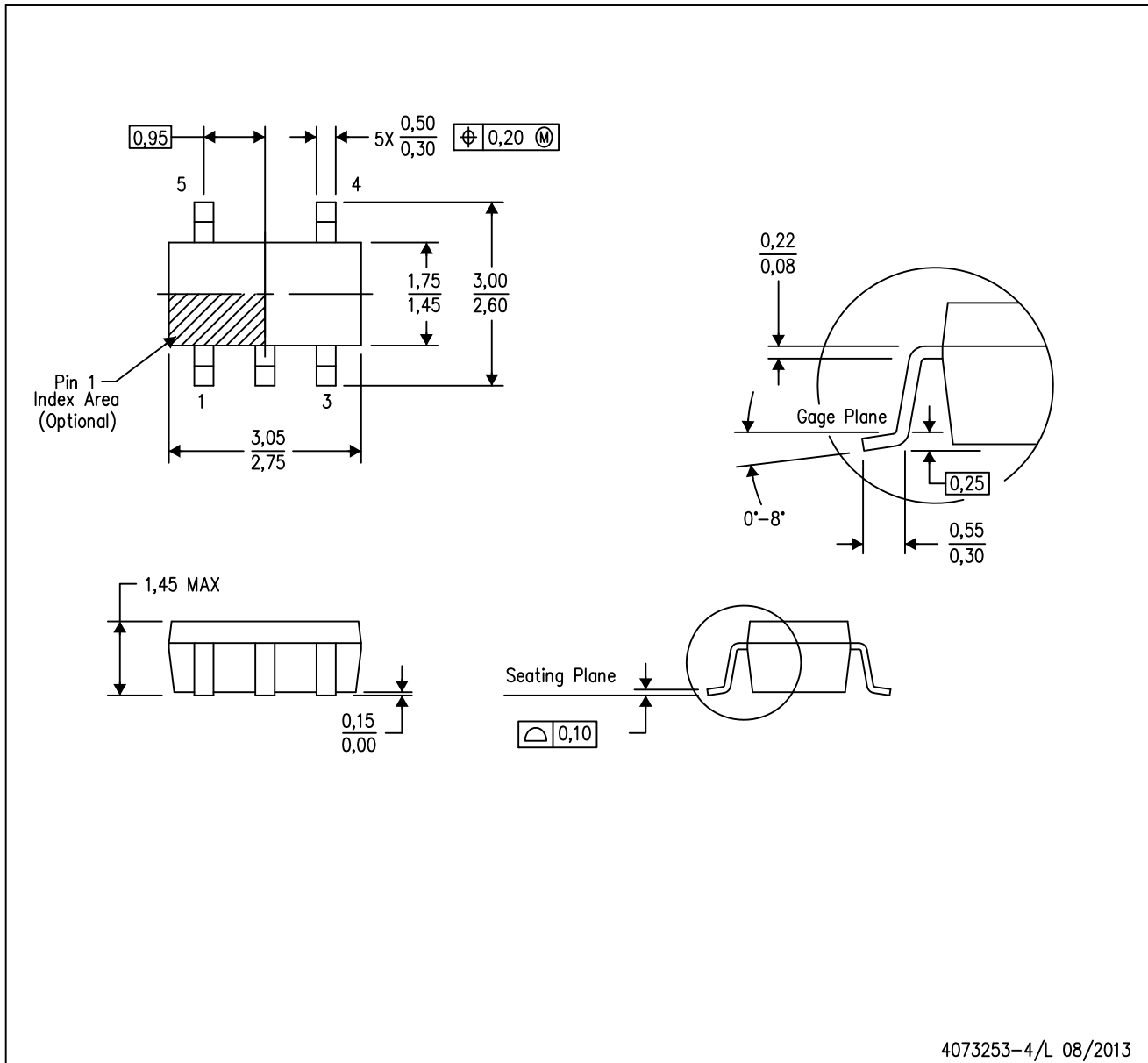
PLASTIC SMALL-OUTLINE PACKAGE



- NOTES:
- A. All linear dimensions are in millimeters.
  - B. This drawing is subject to change without notice.
  - C. Body dimensions do not include mold flash or protrusion. Mold flash and protrusion shall not exceed 0.15 per side.
  - D. Falls within JEDEC MO-178 Variation AA.

DBV (R-PDSO-G5)

PLASTIC SMALL OUTLINE



- NOTES:
- A. All linear dimensions are in millimeters.
  - B. This drawing is subject to change without notice.
  - C. Customers should place a note on the circuit board fabrication drawing not to alter the center solder mask defined pad.
  - D. Publication IPC-7351 is recommended for alternate designs.
  - E. Laser cutting apertures with trapezoidal walls and also rounding corners will offer better paste release. Customers should contact their board assembly site for stencil design recommendations. Example stencil design based on a 50% volumetric metal load solder paste. Refer to IPC-7525 for other stencil recommendations.

## IMPORTANT NOTICE

Texas Instruments Incorporated and its subsidiaries (TI) reserve the right to make corrections, enhancements, improvements and other changes to its semiconductor products and services per JESD46, latest issue, and to discontinue any product or service per JESD48, latest issue. Buyers should obtain the latest relevant information before placing orders and should verify that such information is current and complete. All semiconductor products (also referred to herein as "components") are sold subject to TI's terms and conditions of sale supplied at the time of order acknowledgment.

TI warrants performance of its components to the specifications applicable at the time of sale, in accordance with the warranty in TI's terms and conditions of sale of semiconductor products. Testing and other quality control techniques are used to the extent TI deems necessary to support this warranty. Except where mandated by applicable law, testing of all parameters of each component is not necessarily performed.

TI assumes no liability for applications assistance or the design of Buyers' products. Buyers are responsible for their products and applications using TI components. To minimize the risks associated with Buyers' products and applications, Buyers should provide adequate design and operating safeguards.

TI does not warrant or represent that any license, either express or implied, is granted under any patent right, copyright, mask work right, or other intellectual property right relating to any combination, machine, or process in which TI components or services are used. Information published by TI regarding third-party products or services does not constitute a license to use such products or services or a warranty or endorsement thereof. Use of such information may require a license from a third party under the patents or other intellectual property of the third party, or a license from TI under the patents or other intellectual property of TI.

Reproduction of significant portions of TI information in TI data books or data sheets is permissible only if reproduction is without alteration and is accompanied by all associated warranties, conditions, limitations, and notices. TI is not responsible or liable for such altered documentation. Information of third parties may be subject to additional restrictions.

Resale of TI components or services with statements different from or beyond the parameters stated by TI for that component or service voids all express and any implied warranties for the associated TI component or service and is an unfair and deceptive business practice. TI is not responsible or liable for any such statements.

Buyer acknowledges and agrees that it is solely responsible for compliance with all legal, regulatory and safety-related requirements concerning its products, and any use of TI components in its applications, notwithstanding any applications-related information or support that may be provided by TI. Buyer represents and agrees that it has all the necessary expertise to create and implement safeguards which anticipate dangerous consequences of failures, monitor failures and their consequences, lessen the likelihood of failures that might cause harm and take appropriate remedial actions. Buyer will fully indemnify TI and its representatives against any damages arising out of the use of any TI components in safety-critical applications.

In some cases, TI components may be promoted specifically to facilitate safety-related applications. With such components, TI's goal is to help enable customers to design and create their own end-product solutions that meet applicable functional safety standards and requirements. Nonetheless, such components are subject to these terms.

No TI components are authorized for use in FDA Class III (or similar life-critical medical equipment) unless authorized officers of the parties have executed a special agreement specifically governing such use.

Only those TI components which TI has specifically designated as military grade or "enhanced plastic" are designed and intended for use in military/aerospace applications or environments. Buyer acknowledges and agrees that any military or aerospace use of TI components which have **not** been so designated is solely at the Buyer's risk, and that Buyer is solely responsible for compliance with all legal and regulatory requirements in connection with such use.

TI has specifically designated certain components as meeting ISO/TS16949 requirements, mainly for automotive use. In any case of use of non-designated products, TI will not be responsible for any failure to meet ISO/TS16949.

### Products

Audio	<a href="http://www.ti.com/audio">www.ti.com/audio</a>
Amplifiers	<a href="http://amplifier.ti.com">amplifier.ti.com</a>
Data Converters	<a href="http://dataconverter.ti.com">dataconverter.ti.com</a>
DLP® Products	<a href="http://www.dlp.com">www.dlp.com</a>
DSP	<a href="http://dsp.ti.com">dsp.ti.com</a>
Clocks and Timers	<a href="http://www.ti.com/clocks">www.ti.com/clocks</a>
Interface	<a href="http://interface.ti.com">interface.ti.com</a>
Logic	<a href="http://logic.ti.com">logic.ti.com</a>
Power Mgmt	<a href="http://power.ti.com">power.ti.com</a>
Microcontrollers	<a href="http://microcontroller.ti.com">microcontroller.ti.com</a>
RFID	<a href="http://www.ti-rfid.com">www.ti-rfid.com</a>
OMAP Applications Processors	<a href="http://www.ti.com/omap">www.ti.com/omap</a>
Wireless Connectivity	<a href="http://www.ti.com/wirelessconnectivity">www.ti.com/wirelessconnectivity</a>

### Applications

Automotive and Transportation	<a href="http://www.ti.com/automotive">www.ti.com/automotive</a>
Communications and Telecom	<a href="http://www.ti.com/communications">www.ti.com/communications</a>
Computers and Peripherals	<a href="http://www.ti.com/computers">www.ti.com/computers</a>
Consumer Electronics	<a href="http://www.ti.com/consumer-apps">www.ti.com/consumer-apps</a>
Energy and Lighting	<a href="http://www.ti.com/energy">www.ti.com/energy</a>
Industrial	<a href="http://www.ti.com/industrial">www.ti.com/industrial</a>
Medical	<a href="http://www.ti.com/medical">www.ti.com/medical</a>
Security	<a href="http://www.ti.com/security">www.ti.com/security</a>
Space, Avionics and Defense	<a href="http://www.ti.com/space-avionics-defense">www.ti.com/space-avionics-defense</a>
Video and Imaging	<a href="http://www.ti.com/video">www.ti.com/video</a>

### TI E2E Community

[e2e.ti.com](http://e2e.ti.com)